

MONTAGE - HR1-A

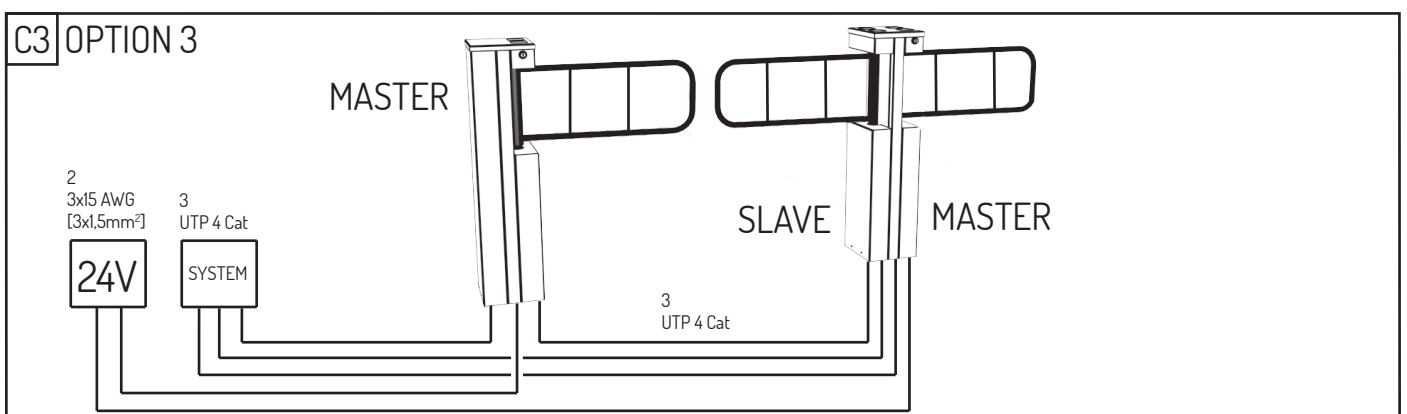

EN Complete documentation:

- GENERAL INFORMATION
- PEDESTRIAN TRAFFIC CONTROL
- DEVICE
- MONTAGE
- MAINTENANCE AND SERVICE
- TECHNICAL DRAWINGS

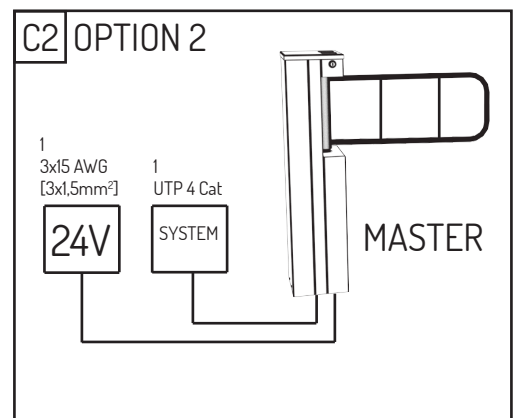
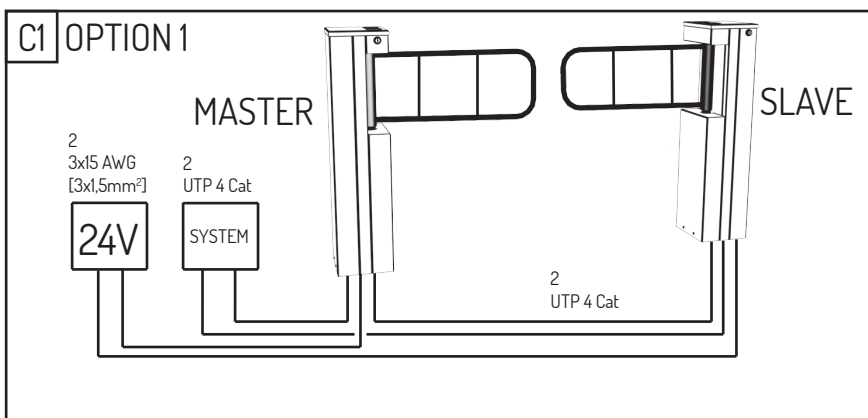
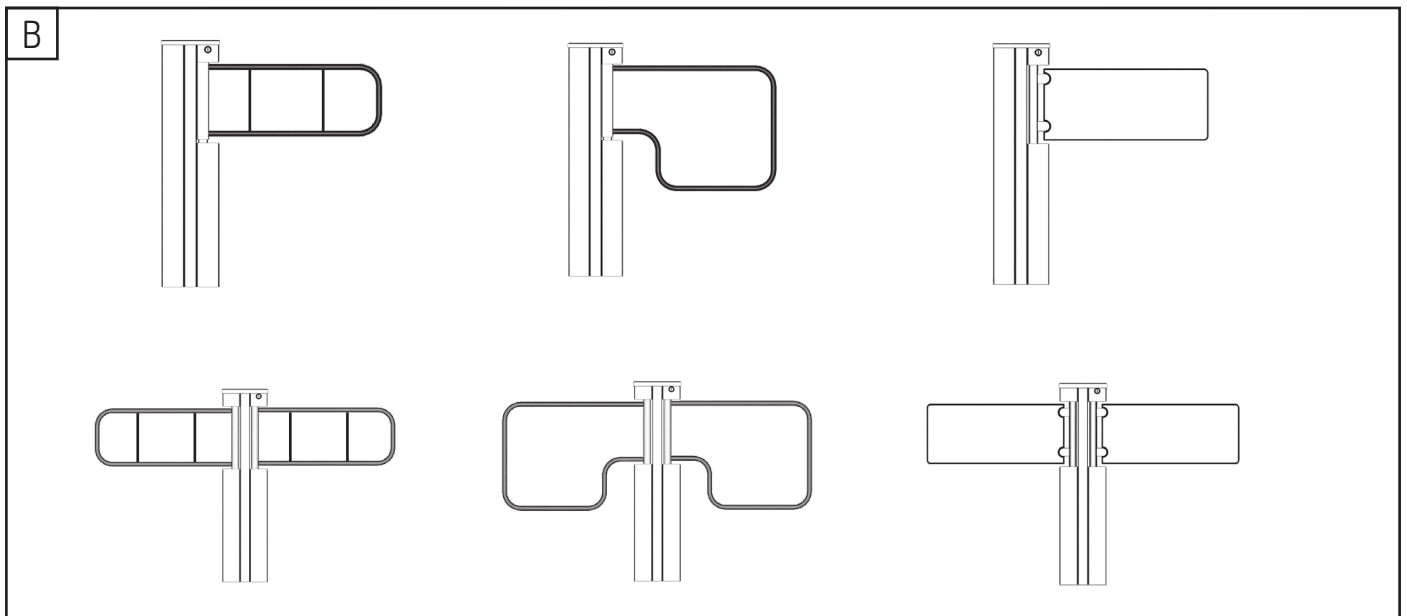
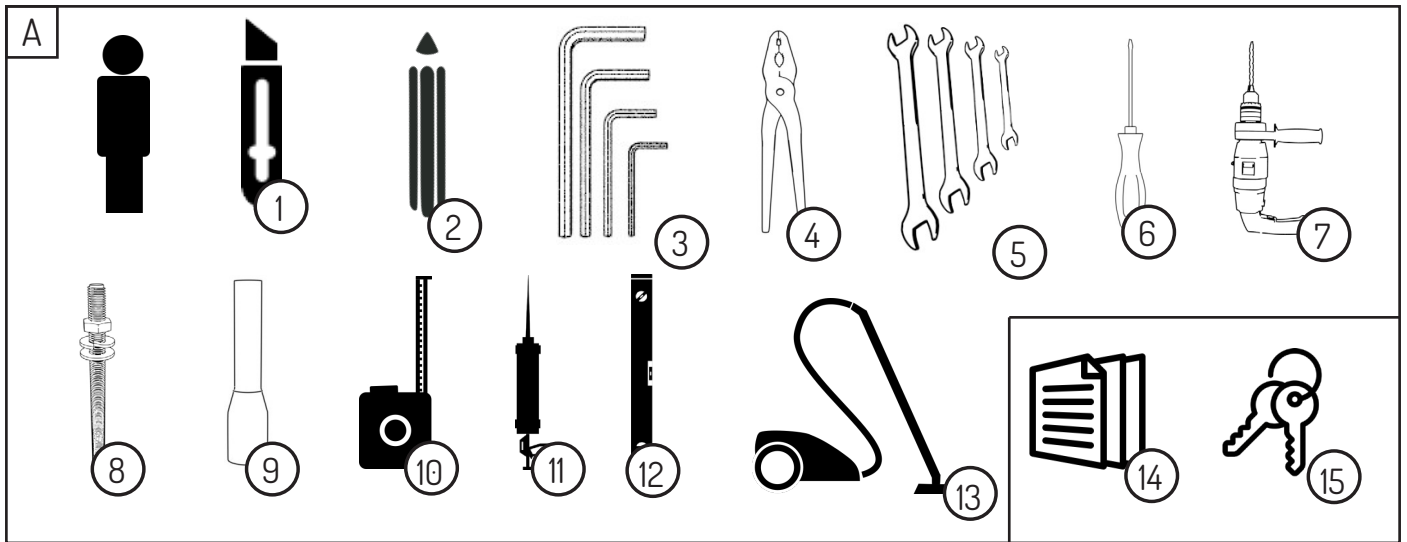

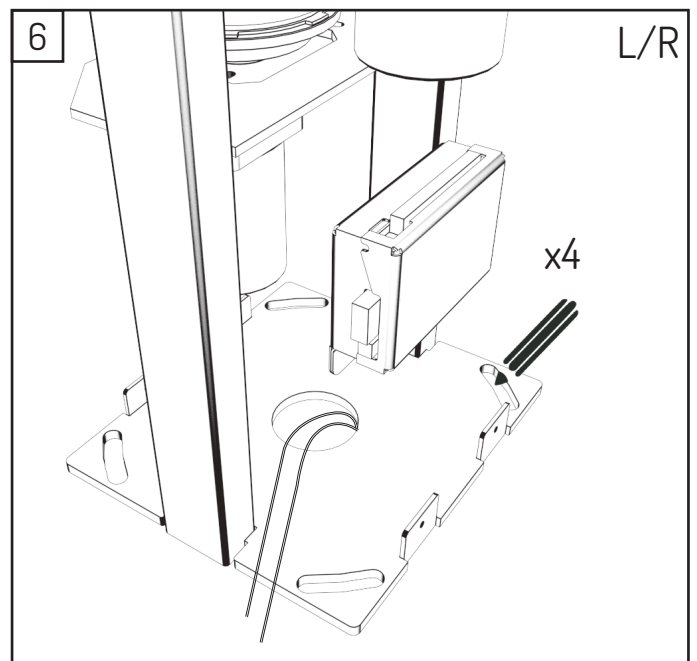
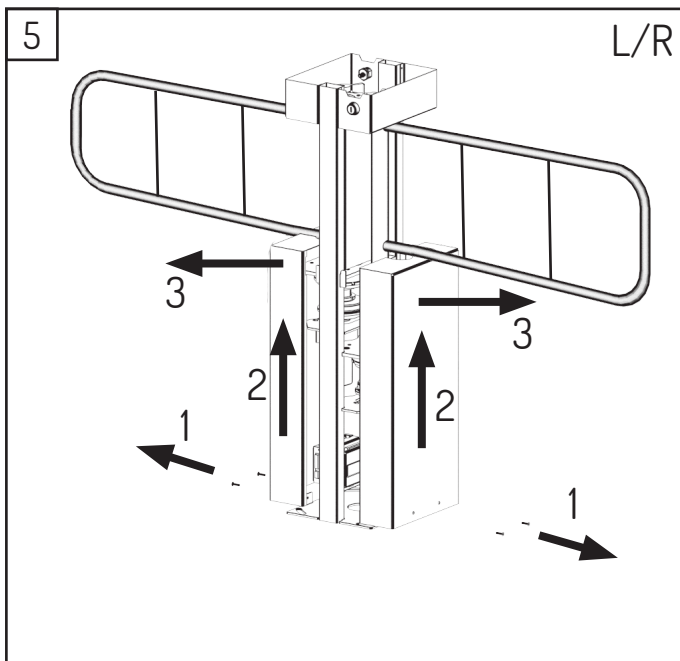
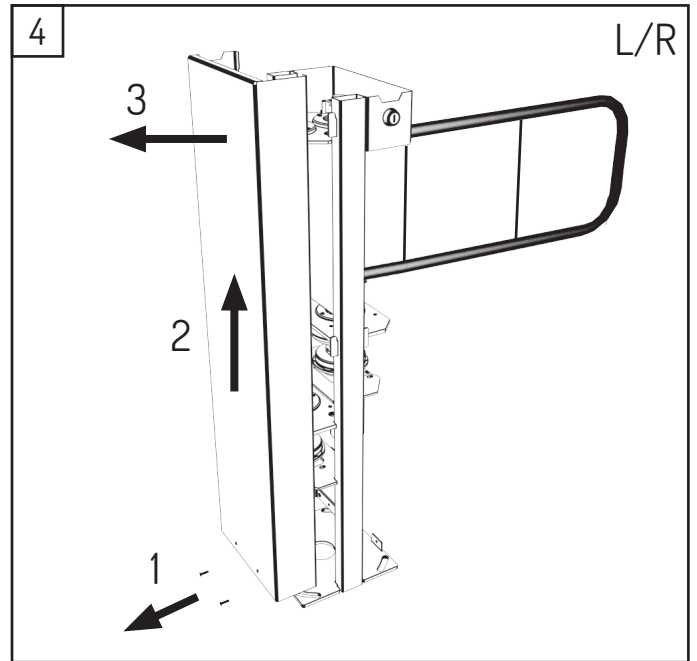
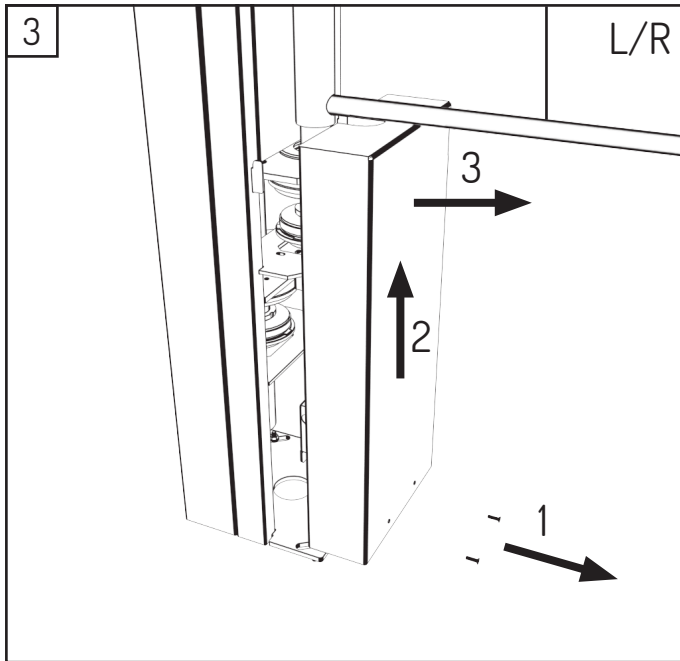
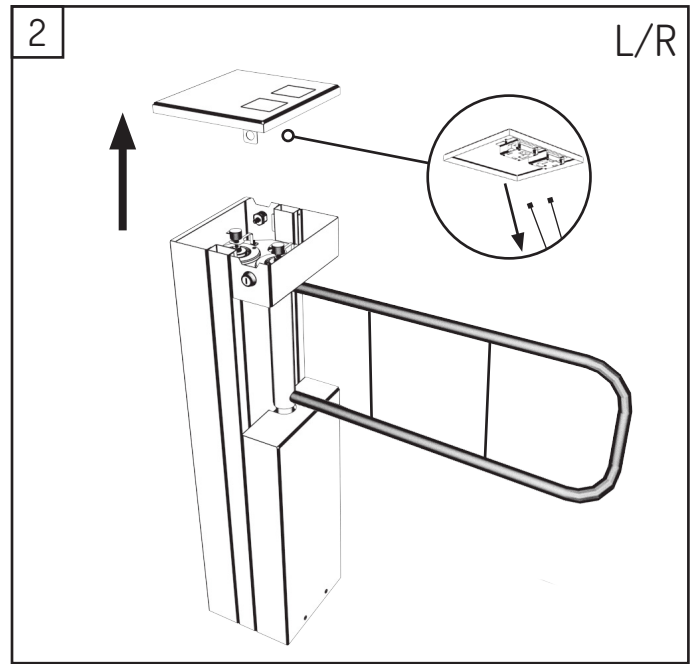
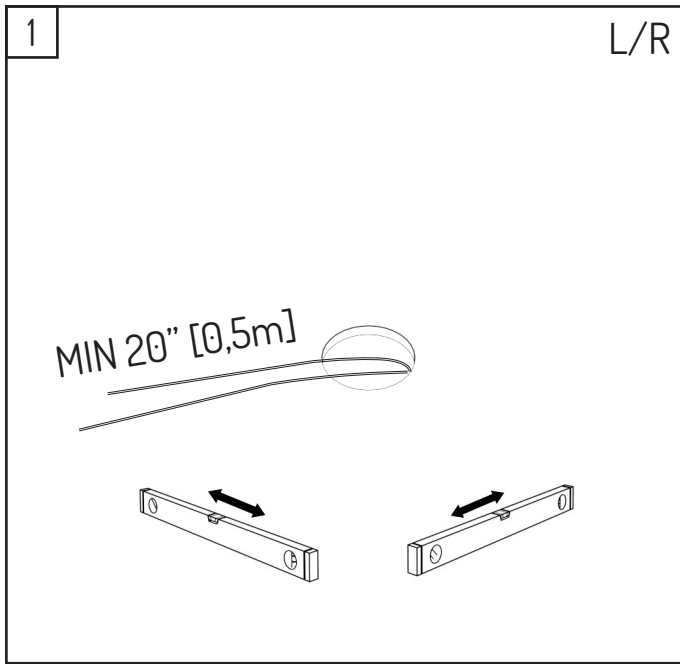

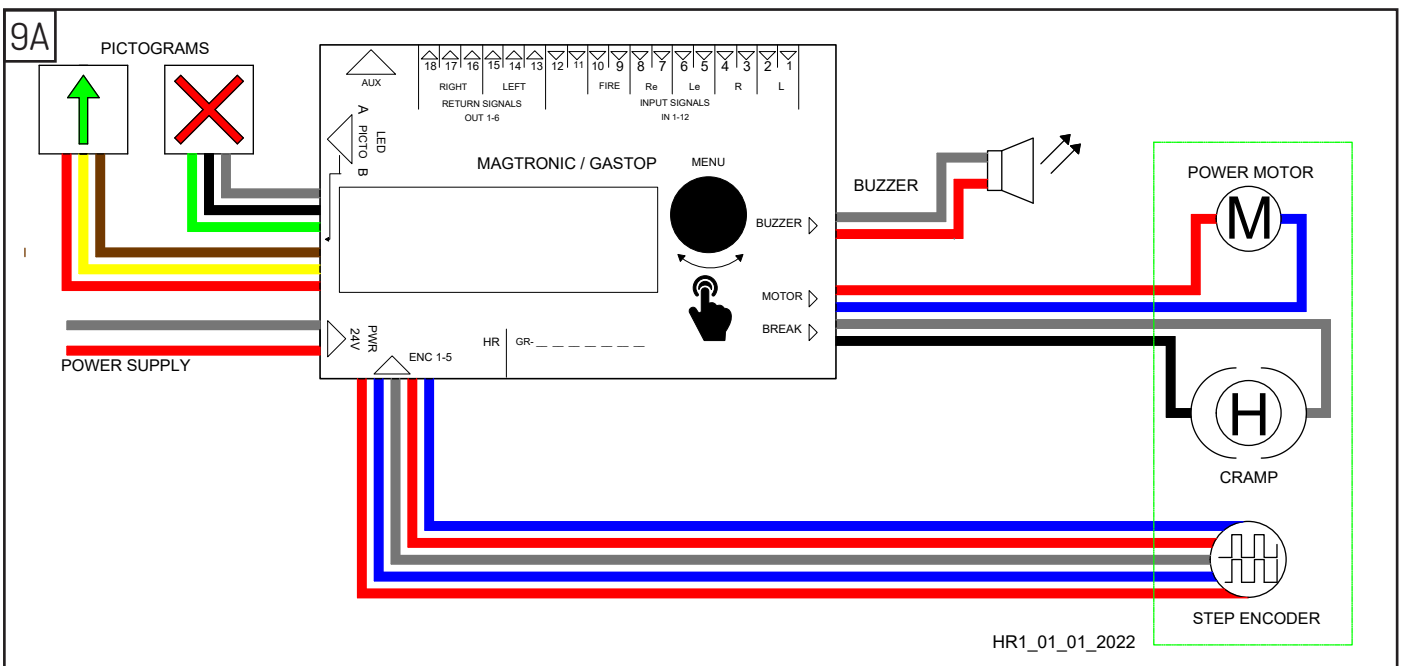
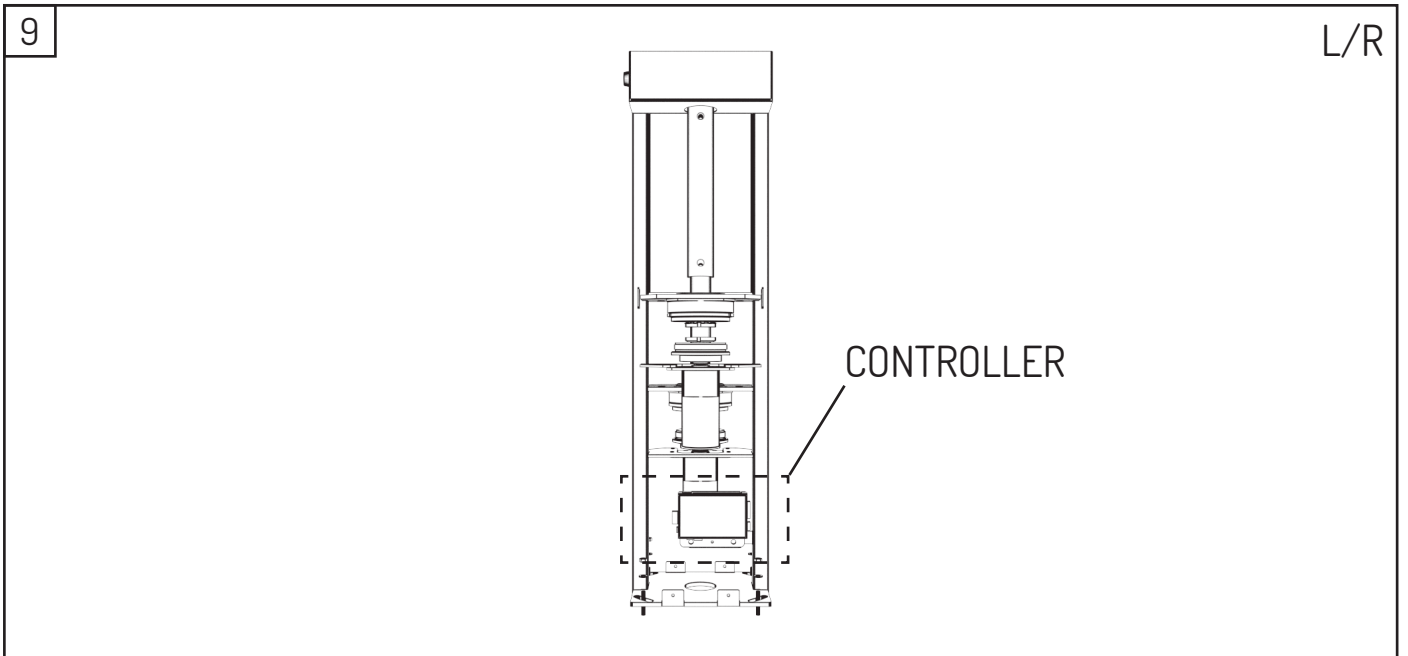
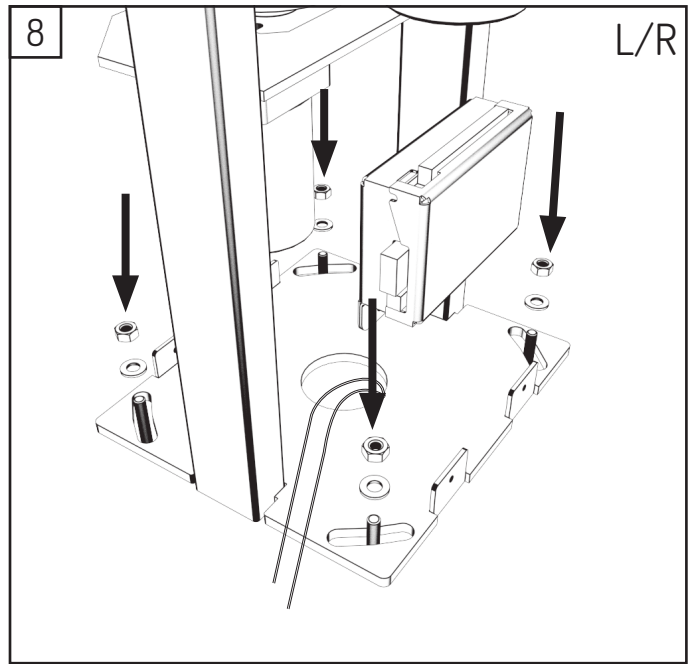
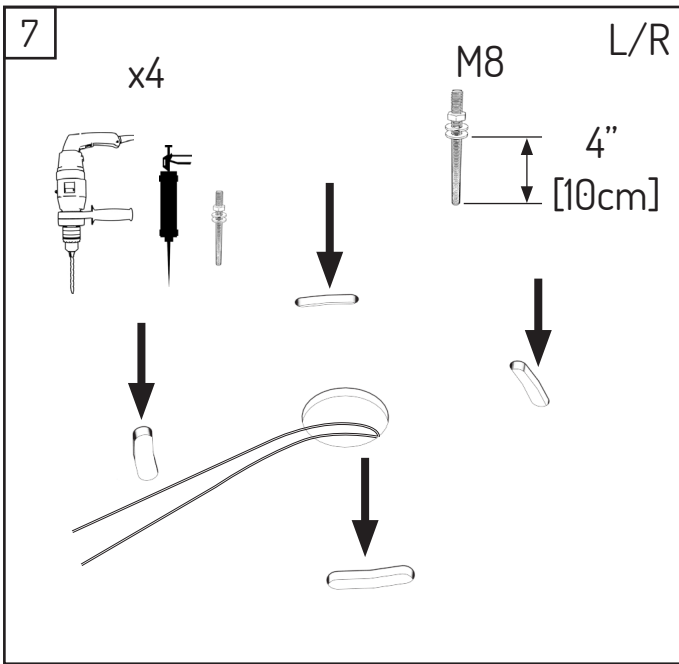

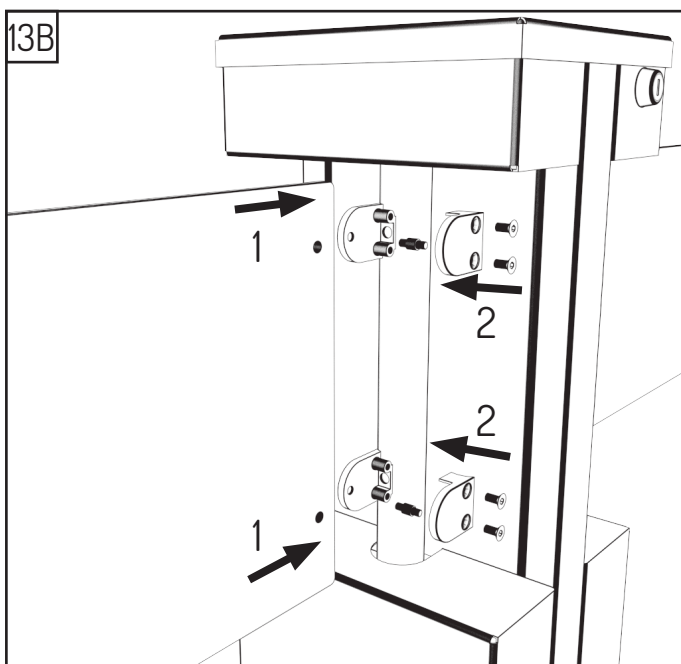
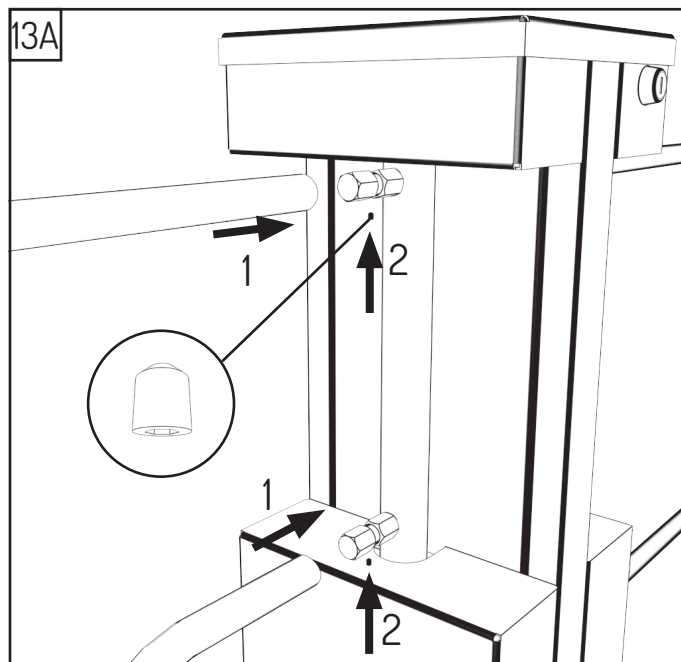
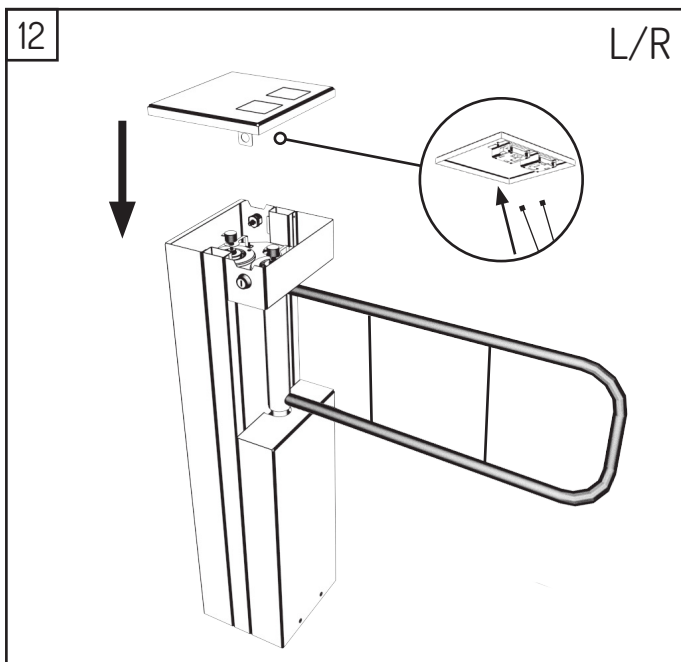
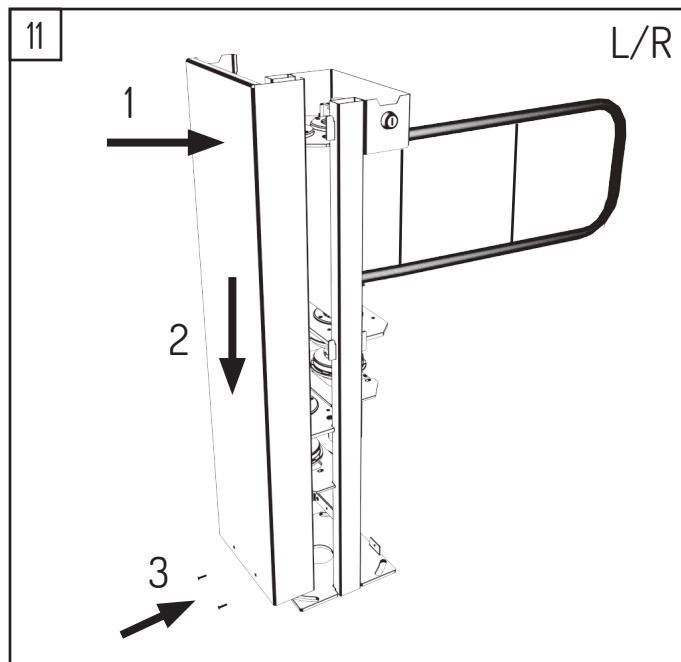
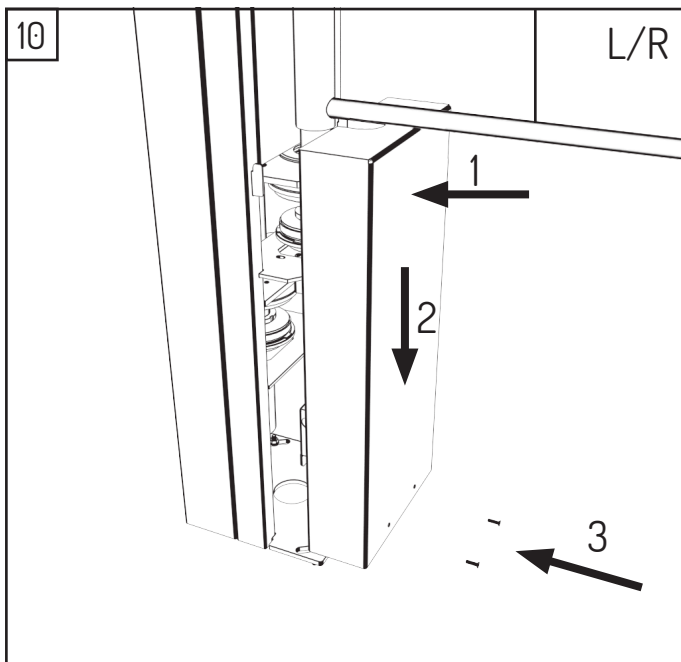

Before assembly, read the complete technical and operational documentation of the device. This short installation guide serves exclusively for the illustration of some important steps in the installation process.

A. Basic tools and items needed to install the device*:

1. Knife to cut the device's packaging.
2. Marker for marking holes on the ground.
3. Allen key set.
4. Pliers for electrical installation.
5. Set of wrenches.
6. Flat-head screwdriver.
7. Electric drill
8. Injection (chemical) anchors – 4 anchors for each device.
9. Cable ends (ferrules).
10. Measuring tape.
11. Glue gun.
12. Spirit level.
13. Vacuum cleaner.
14. Technical documentation.
15. Set of keys.

*Tools and items listed in points 1 to 13 inclusive are not part of the device set.

* One person is required to assemble the device.

B. Examples of different versions of the HR1 device.

- C1. HR1-A gates in the MASTER / SLAVE synchronous system.
- C2. HR1-A gate in a single MASTER system.
- C3. HR1-A and HR1-A2 gates in the MASTER / SLAVE synchronous system, and single MASTER system.

1. Pulling the cables out of the ground to a length of min. 0.5 m and checking the level.
2. Opening locks and removing the top.
3. Unscrewing two screws and removing the front cover for the HR1-A device.
4. Unscrewing two screws and removing the back cover for the HR1-A device.
5. Unscrewing four screws and removing the covers for the HR1-A2 device.
6. Marking the fixing points on the ground to drill the holes.
7. Drilling holes, inserting glue into holes and inserting anchors into holes filled with glue in accordance with the instructions of the glue manufacturer. After introducing the glue into the holes, wait for the amount of time specified by the glue manufacturer.
8. Tightening the anchors with nuts (a spring washer and a plain washer should be placed under the nut).
9. Location of electronics in devices.
- 9A. Electrical diagram.
10. Mounting the bottom covers and tightening the screws for HR1-A and HR1-A2 devices.
11. Mounting the back cover and tightening the screws for HR1-A device.
12. Putting the top on and closing the locks.
- 13A. For the device with a metal arm, inserting and tightening the arm with setscrews.
- 13B. For the device with a glass arm, inserting and tightening the glass using special glass holders.



EU: GASTOPGROUP.COM
USA: GASTOP.US