

DEVICE - HR1-M/A, GR1-M/A





## TABLE OF CONTENTS

DESCRIPTION OF DEVICES.....	5
MARKING OF DEVICES.....	6
SUMMARY TABLE.....	6
TYPES OF ELECTRICAL MECHANISMS - SWING GATES HRI / GRI - M / A.....	6
LIST OF FUNCTIONS OF PARTICULAR MODELS OF SWING GATES.....	6
TECHNICAL PARAMETERS.....	7
GENERAL OPERATING PRINCIPLE.....	7
MARKING ON DEVICES.....	7
DETAILED DESCRIPTION OF THE ELEMENTS OF HRI/GRI - M/A MECHANISM.....	8
TRANSPORT.....	8
PLACES OF PERIODIC REPLENISHMENT OF LUBRICATION.....	9
HRI/GRI-A WORKING MODE.....	9
HRI/GRI-M OPERATING MODE.....	9
SETTING OF THE ZERO POSITION OF THE GRI SERIES.....	10
LOCATION / REPLACEMENT OF THE FUSE.....	10

## DESCRIPTION OF DEVICES

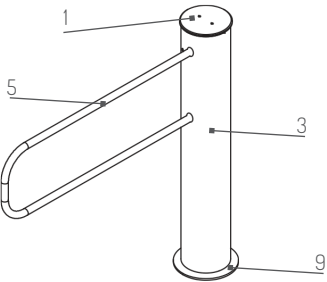
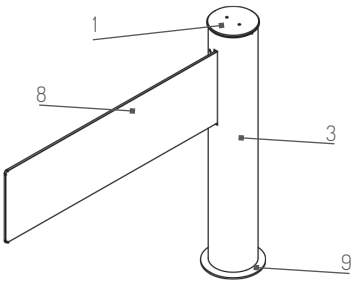
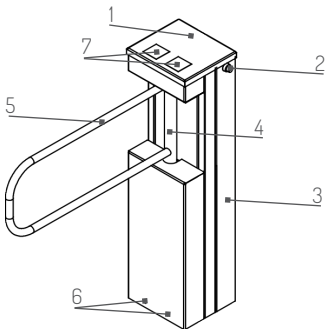
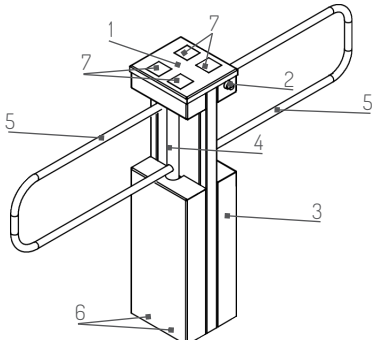
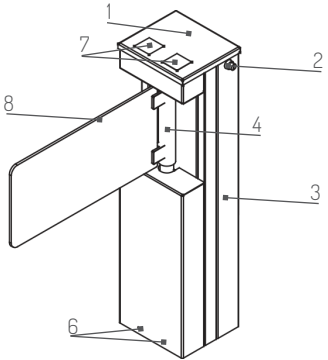
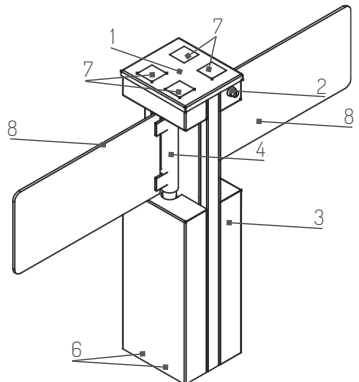
GRI-M / GRI-A	GRI-A-S
	
HRI-M / HRI-A	HRI-M2 / HRI-A2
	
HRI-A-S	HRI-A2-S
	

**(1)** upper top made of AISI 304 (EN 10088) stainless steel, **(2)** key lock, **(3)** device casing made of AISI 304 (EN 10088) ground stainless steel, **(4)** gate arm rotation axis made of AISI 304 (EN 10088) ground stainless steel, **(5)** gate arm made of circular profile, **(6)** mounting holes for the frame, **(7)** pictograms, **(8)** glass arm, **(9)** masking rosette, **(10)** gate leg

## MARKING OF DEVICES

Description of markings	Series (HRI / GRI)	Model (M/A)	Number of passes / arms (1/2)
Example of marking	HRI	M	2

Description of the example of marking:

- HRI-M2 - HRI series, model M (manual), number of passes - 2 (double)

**M** - manual  
**A** - automatic  
**S** - glass arm

**NOTE:** Standard finish is AISI 304 (INOX) stainless steel.

## SUMMARY TABLE

	HRI-M	HRI-M2	HRI-A	HRI-A-S	HRI-A2	HRI-A2-S	GRI-M	GRI-A	GRI-A-S
One arm, one mechanism, controller	•		•	•			•	•	
Two arms, two mechanisms, controller		•			•	•			
Emergency unlocking*	•	•	•	•	•	•	•	•	•
Internal use - under shelter	•	•	•	•	•	•	•	•	•
Sound signalling	•	•	•	•	•	•	•	•	•
Pictogram signaling	•	•	•	•	•	•			

\* - Emergency unlocking: after cutting off the voltage from the device, the gate arm is unlocked. Easing the passage consists in the mechanical pushing the gate arm. In the event of providing an emergency signal to the gate (HRI / GRI - A - automatic) the arm unlocks and swings by itself.

## TYPES OF ELECTRICAL MECHANISMS - SWING GATES HRI / GRI - M / A

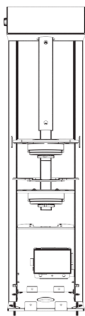
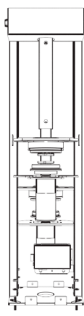
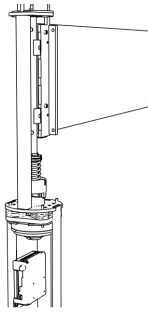
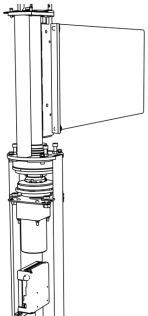
HRI-M	HRI-A	GRI-M	GRI-A
			

## LIST OF FUNCTIONS OF PARTICULAR MODELS OF SWING GATES

PARAMETER	HRI/GRI-M	HRI/GRI-A
Function - cooperation with an external electronic access control system	•	•
Mechanism designed for continuous (industrial) work	•	•
Supporting arm movement (electromechanical - electric motor - automatic gate)		•
Supporting return arm movement (mechanical - spring - manual gate)	•	
Control - controller, 24V power supply	•	•
Electronic positioning / measuring system (encoder)	•	•
Mechanical unlocking the direction of passage in the event of power failure	•	•

## TECHNICAL PARAMETERS

PARAMETER	HRI/GRI - M/A	HRI/GRI - M2/A 2
Supply voltage:	-24VAC	(2x) -24VAC
Maximum power consumption:	60 VA	(2x) 60 VA
Minimum power consumption:	2.5 A	(2x) 2.5 A
Control signal (configurable):	(max. 0.5 sec)	(max. 0.5 sec)
Feedback signal (configurable):	potential-free NO/NC	potential-free NO/NC
Operating temperature:	-25° to +50° C	-25° to +50° C
Storage temperature:	-30° to +60° C	-30° to +60° C
Insulation class IP:	IP 33	IP 33
Maximum operating humidity:	80 %	80 %
Operating conditions:	indoor	indoor

## GENERAL OPERATING PRINCIPLE

Swing, automatic and manual gates are designed to manage and support the control of passenger traffic in guarded places, as well as technical passes with gate systems from the BR2/GA2 series. It is possible to connect them to motion detection devices, alarm systems and fire protection systems.

The device, after receiving the signal from an external system, takes control over blocking and passage (HRI/GRI - A models equipped with an engine) of the arm for both directions of traffic. Depending on the version, the device is equipped with mechanical (HRI/GRI - M) or electromechanical (HRI/GRI - A) support for arm movement. In the case of manual gates (HRI/GRI-M) swinging of the gate arm above 90° causes it to block.

In the event of a power failure, the gate can be opened permanently by swinging the arm above 90° from the initial position.

Sound signaling informs about the attempt to force the arm when the gate is closed (without authorization). It also signals an attempt to open the gate in the opposite direction than the one commanded and in case of stopping the movement of the arm.

## MARKING ON DEVICES

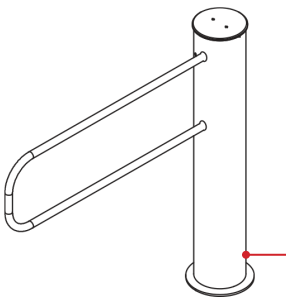
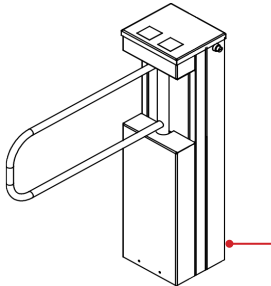
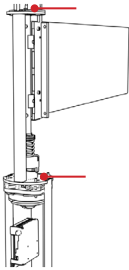
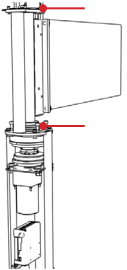
Marking places on devices (warranty seals)			
Construction GRI - M/A	Construction HRI-M/A	HRI/GRI - M	HRI/GRI - A
			
Nameplate (CE mark, device series designation, nominal voltage, operating temperature)		Warranty seals.	

**WARNING:** In order to maintain the warranty and warranty of the device manufacturer, do not remove or damage the warranty seals and serial numbers of the device. Removal or damage to warranty seals and serial numbers will void the warranty on the device.

## DETAILED DESCRIPTION OF THE ELEMENTS OF HRI/GRI - M/A MECHANISM

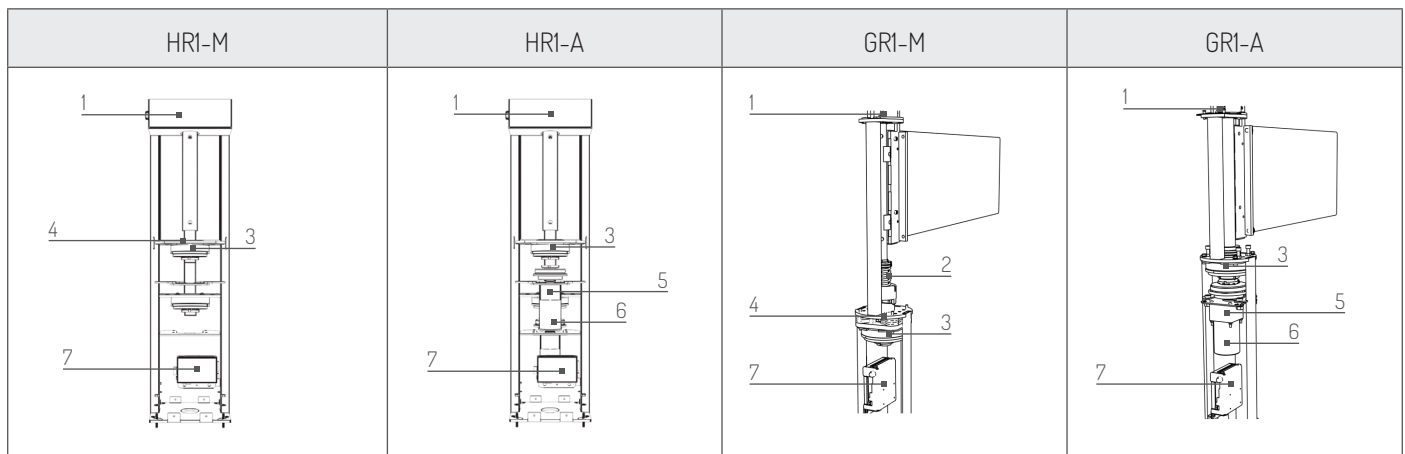

POS.	NAME	POS.	NAME
1.	Encoder	5.	Transmission
2.	Pressure spring	6.	Engine
3.	Electromagnetic jumper	7.	Controller
4.	Bearing	8.	Sounder

## TRANSPORT

### MEANS OF TRANSPORT

The devices must be transported in covered means of transport. During transport, the devices should be secured against moving and be in a position consistent with the warning signs or in the absence of such markings in a vertical position. Transport protection must be installed before transporting the device.

### FORCE PROTECTION

The force protection is created by attaching the load to the car using belts, ropes, etc. All devices should be attached to the truck from all sides. A prerequisite for secure fastening with ropes is the presence of suitable anchorage points in the middle of the vehicle. It is recommended to use textile fastening belts with appropriate carrying capacity and hanging brackets.

### RISKS RELATED TO TRANSPORT

When transporting with a forklift, pay attention to the permissible lifting capacity and the dimensions of the forks. Use equipment for work at height, when working above body height. Do not use parts of the device to climb.

### PACKAGING AND UNPACKAGING OF DEVICES

The devices are secured for transport with foil and cardboard packaging.

MODEL	HRI-M	HRI-M2	HRI-A	HRI-A-S	HRI-A2	HRI-A2-S	GRI-M	GRI-A	GRI-A-S
WEIGHT - [kg/lbs]	45/99	52/114	46/101	48/106	57/125	59/130	29/63	31/64	34/64

### Procedure for packing:

Parts of the device should be transported only in upright position. The points of contact with the forklift truck or other lifting equipment should be protected against damage. Completeness check should be carried out.

Procedure for removing the package:

Make sure that the transport protection is removed. Check the device for transport damage. Carry out completeness check. In case of transport damage or lack of completeness, inform the seller and the responsible forwarding agent immediately. Use appropriate tools (such as scissors or knives) to remove the packaging. The packaging should be disposed of in accordance with the applicable environmental regulations.

## PLACES OF PERIODIC REPLENISHMENT OF LUBRICATION

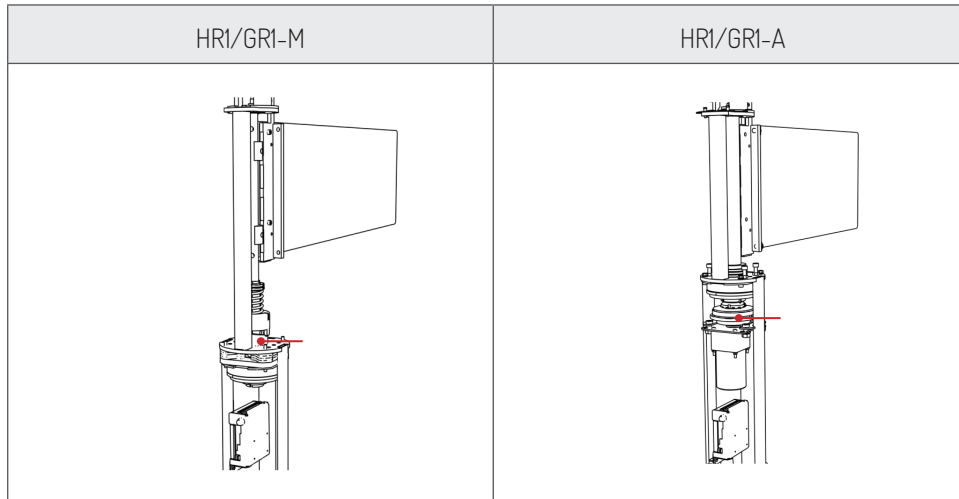

Fig. Place for periodic replenishment of lubrication (HRI/GRI-A: clutch; HRI/GRI-M: mechanism.)

The frequency of lubrication and the recommended preparations are specified in the "maintenance" section.

## HRI/GRI-A WORKING MODE

After connecting the device to the power supply, the device waits for an external signal, e.g. from a reader, button or other control device (visual signaling for HRI gates – red cross). After receiving the external control signal, the arm of the device swings to let the authorized person pass (visual signaling for HRI gates – green arrow). After approx. 7 seconds, the arm returns to the initial position, the electronic system sends a feedback signal informing about the passage and the device goes back to the standby position, waiting for the external signal.

In the case when the arm, automatically performing the movement, encounters an obstacle that will prevent further movement, the mechanism will automatically disable the mechanism engine (for HRI/GRI-A gate) in about 7 sec. and the mechanism will remain in the unblocked state until the next external signal is received. In the case of an attempt to force the gate, the sound signaling is activated and the gate remains in the blocked state. After return of the arm to the point "0", the sound signaling automatically turns off.

## HRI/GRI-M OPERATING MODE

After connecting the device to the power supply, the device waits for an external signal, e.g. from a reader, button or other control device (visual signaling for HRI gates – red cross). After receiving the external control signal, the blockade of movement of the gate arm is released enabling the authorized person to pass (visual signaling for HRI gates – green arrow). The arm of the gate returns to the point "0" by means of a spring mechanism after the person has passed and released the gate arm.

In the case of an attempt to force the gate, the sound signaling is activated and the gate remains in the blocked state. After return of the arm to the point "0", the sound signaling automatically turns off.

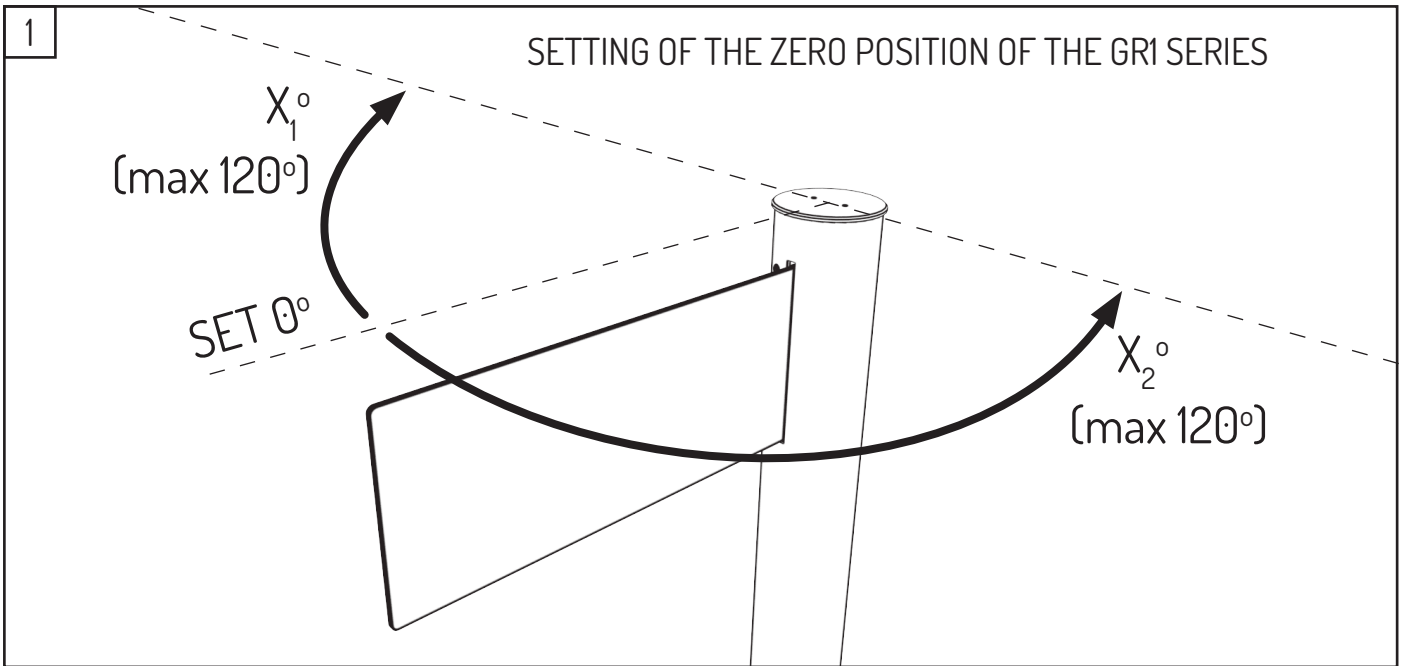

## LOCATION / REPLACEMENT OF THE FUSE

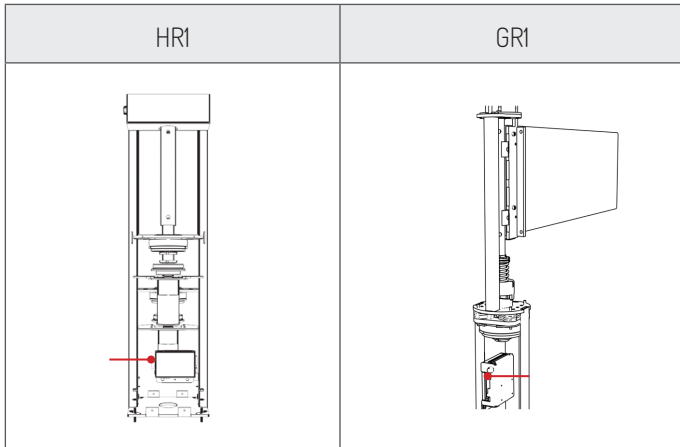

The fuse is integrated with the gate controller. Replacement consists of removing its housing, replacing it with a new one and closing the housing.





EU: [GASTOPGROUP.COM](http://GASTOPGROUP.COM)  
USA: [GASTOP.US](http://GASTOP.US)