



# TM2-BR2AL

TECHNICAL DRAWINGS

ALL RIGHTS RESERVED BY GASTOP PRODUCTION LTD

03.2026

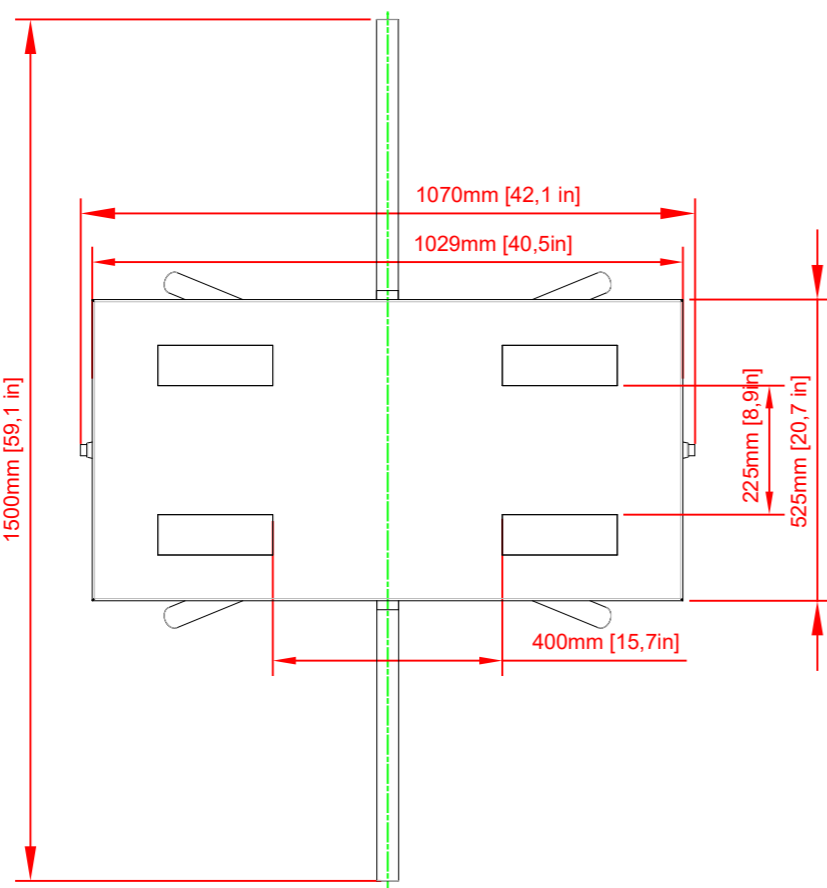
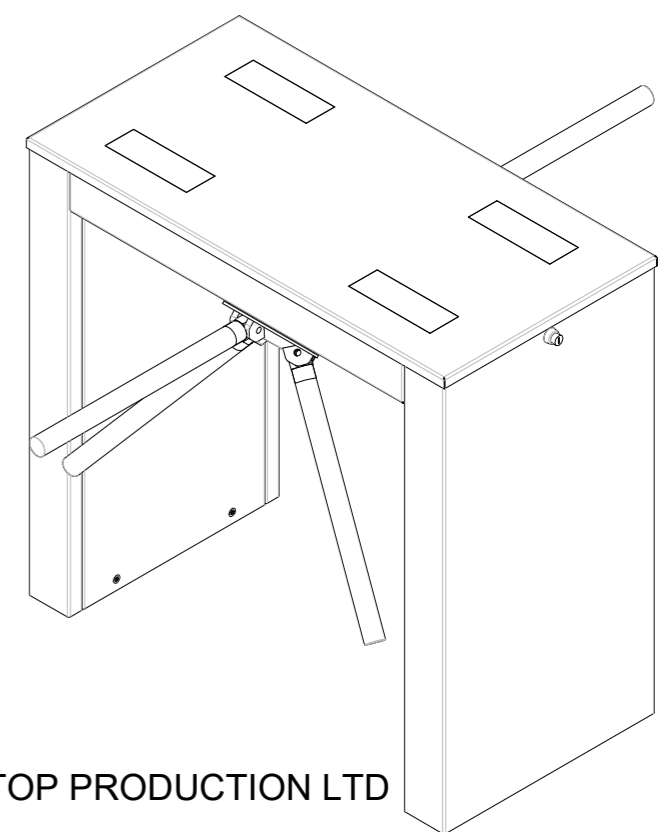
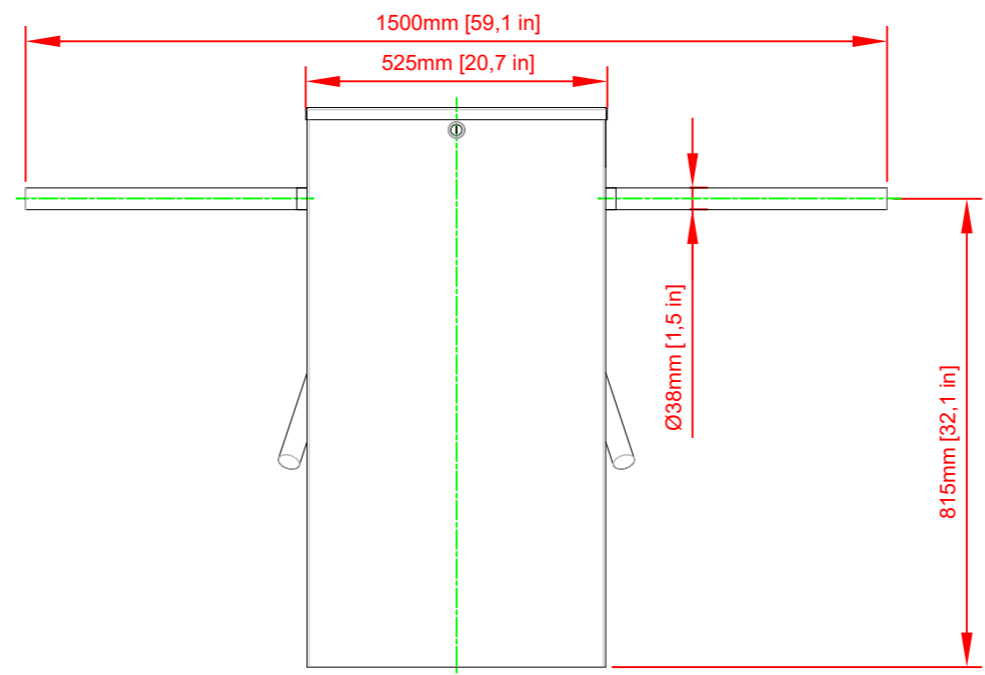
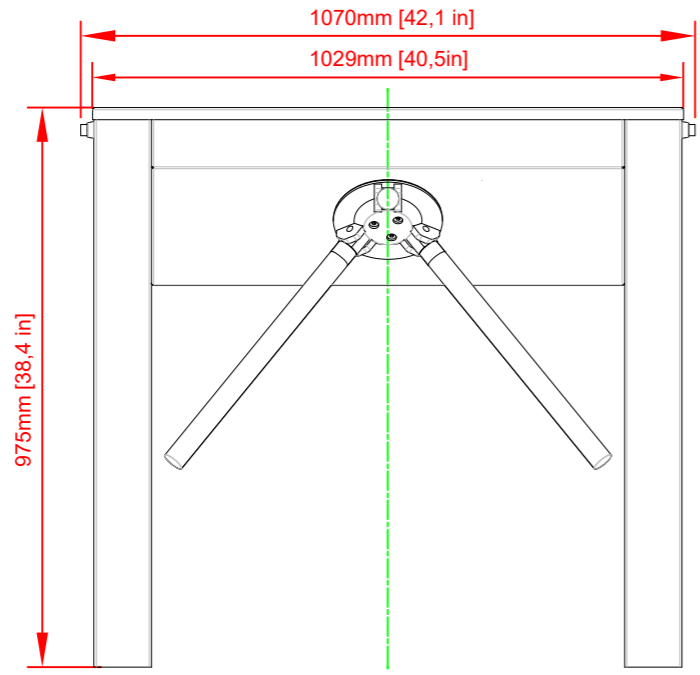
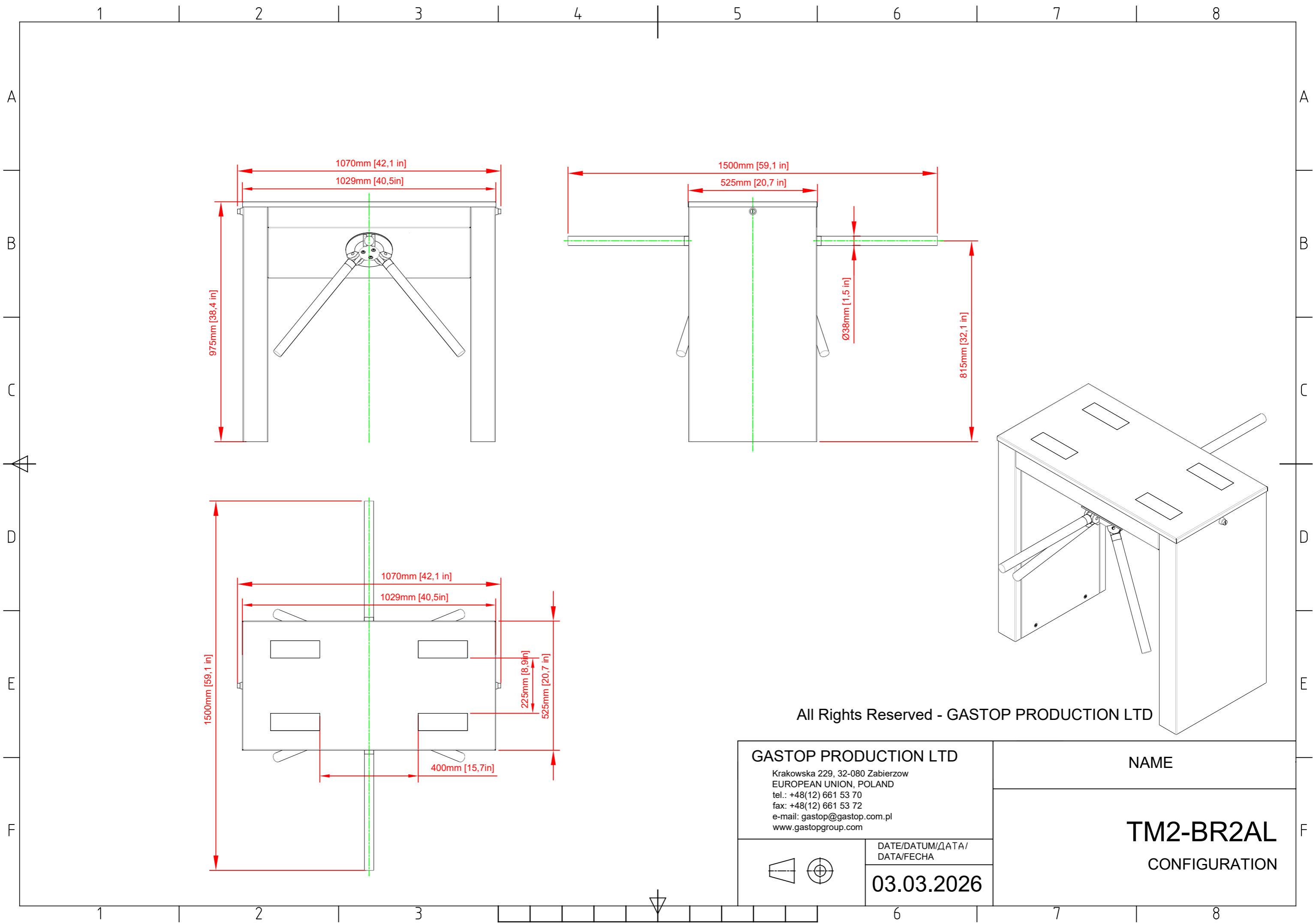

All Rights Reserved - GASTOP PRODUCTION LTD

**GASTOP PRODUCTION LTD**  
 Krakowska 229, 32-080 Zabierzow  
 EUROPEAN UNION, POLAND  
 tel.: +48(12) 661 53 70  
 fax: +48(12) 661 53 72  
 e-mail: gastop@gastop.com.pl  
 www.gastopgroup.com

DATE/DATUM/DATA/  
 DATA/FECHA  
**03.03.2026**

NAME
<b>TM2-BR2AL</b>
CONFIGURATION

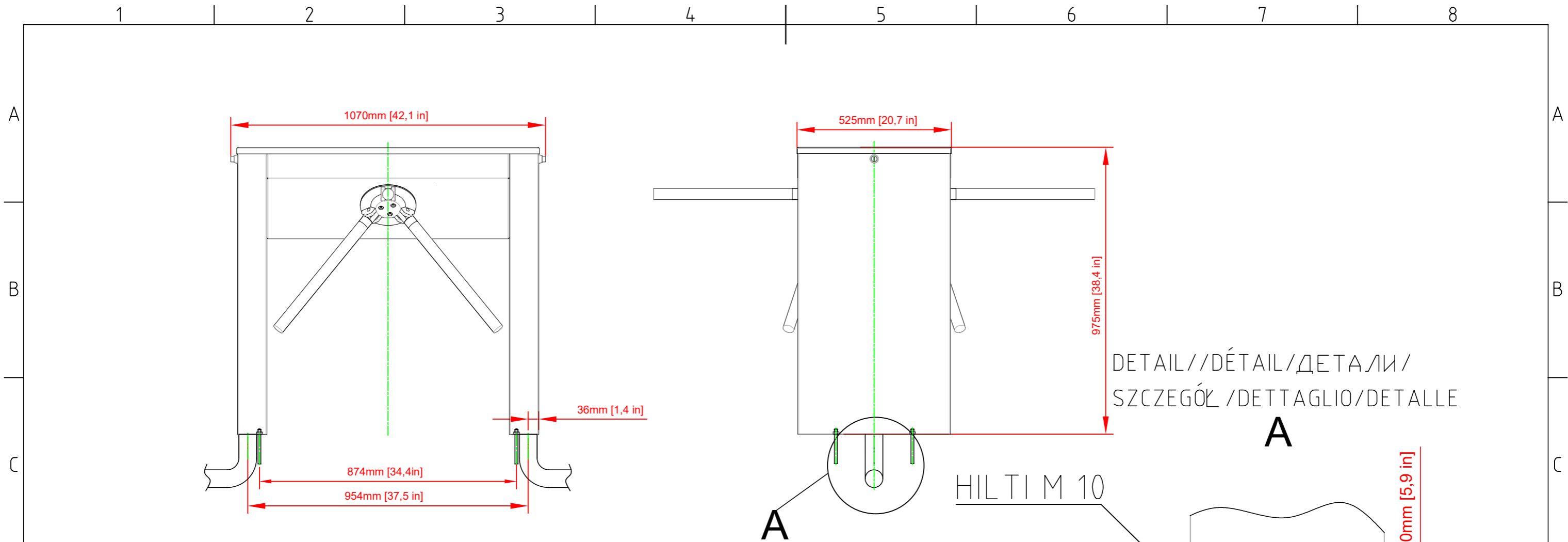

DETAIL//DÉTAIL/ДЕТАЛИ/  
SZCZEGÓŁ /DETTAGLIO/DETALLE

A

A

HILTI M 10

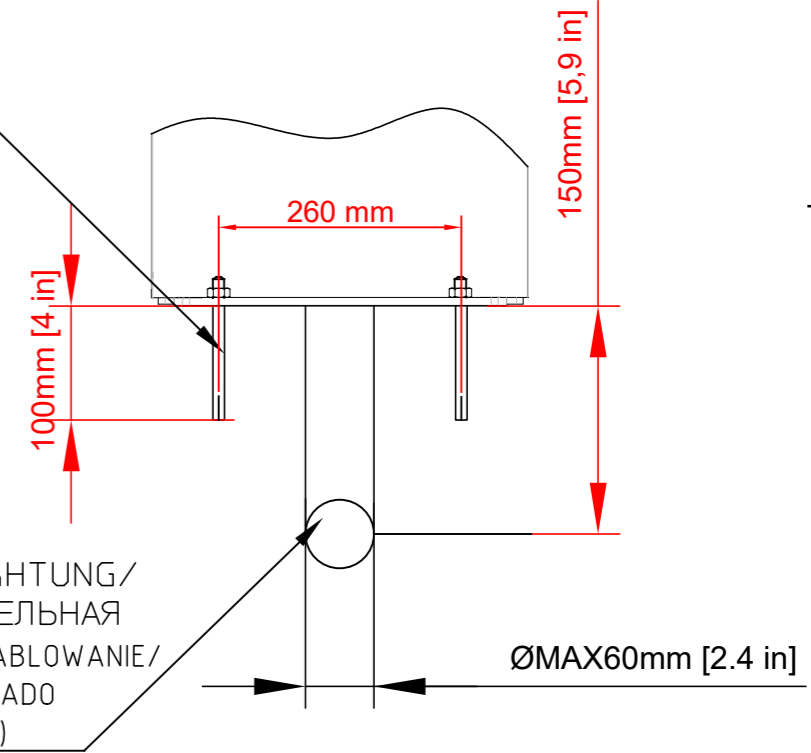

WIRING/VERDRÄHTUNG/  
CABLAGE / КАБЕЛЬНАЯ  
ПРОВОДКА / OKABLOWANIE/  
CABLAGGIO/CABLEADO  
(MAX Ø60mm/2,4in)

Note  
1. Controllers, readers, adaptors, wires, protective pipes are not components of the device.

Bemerkung:  
1. Steuereinheiten, Leser, Netzteile, Leitungen, Peschelrohre sind keine Bestandteile der Anlage.

ATTENTION!  
1. LECTEURS, CONTROLEURS, PUISSANCE ELECTRIQUE, CABLES, TUYAUX FLEXIBLES, NE SONT PAS COMPOSANTS DU DISPOSITIF.

Примечание:  
1. Контроллеры, считывающие устройства, питатели, провода, пешели не являются составными частями оборудования.

Uwaga:  
1. Sterowniki, czytniki, zasilacze, przewody, peszle nie stanowią części składowych urządzenia.

Attenzione:  
1. Controlleri, lettori, alimentatore, cavi, tubetti non fanno parte delle parti integrate del dispositivo.

Atención:  
1. Drivers, lectores, alimentadores, cables, tubos no son parte de componentes del dispositivo.

All Rights Reserved - GASTOP PRODUCTION LTD

<b>GASTOP PRODUCTION LTD</b> Krakowska 229, 32-080 Zabierzow EUROPEAN UNION, POLAND tel.: +48(12) 661 53 70 fax: +48(12) 661 53 72 e-mail: gastop@gastop.com.pl www.gastopgroup.com	NAME
	<b>TM2-BR2AL</b> INSTALATION
	DATE/DATUM/DATA/ DATA/FECHA <b>03.03.2026</b>

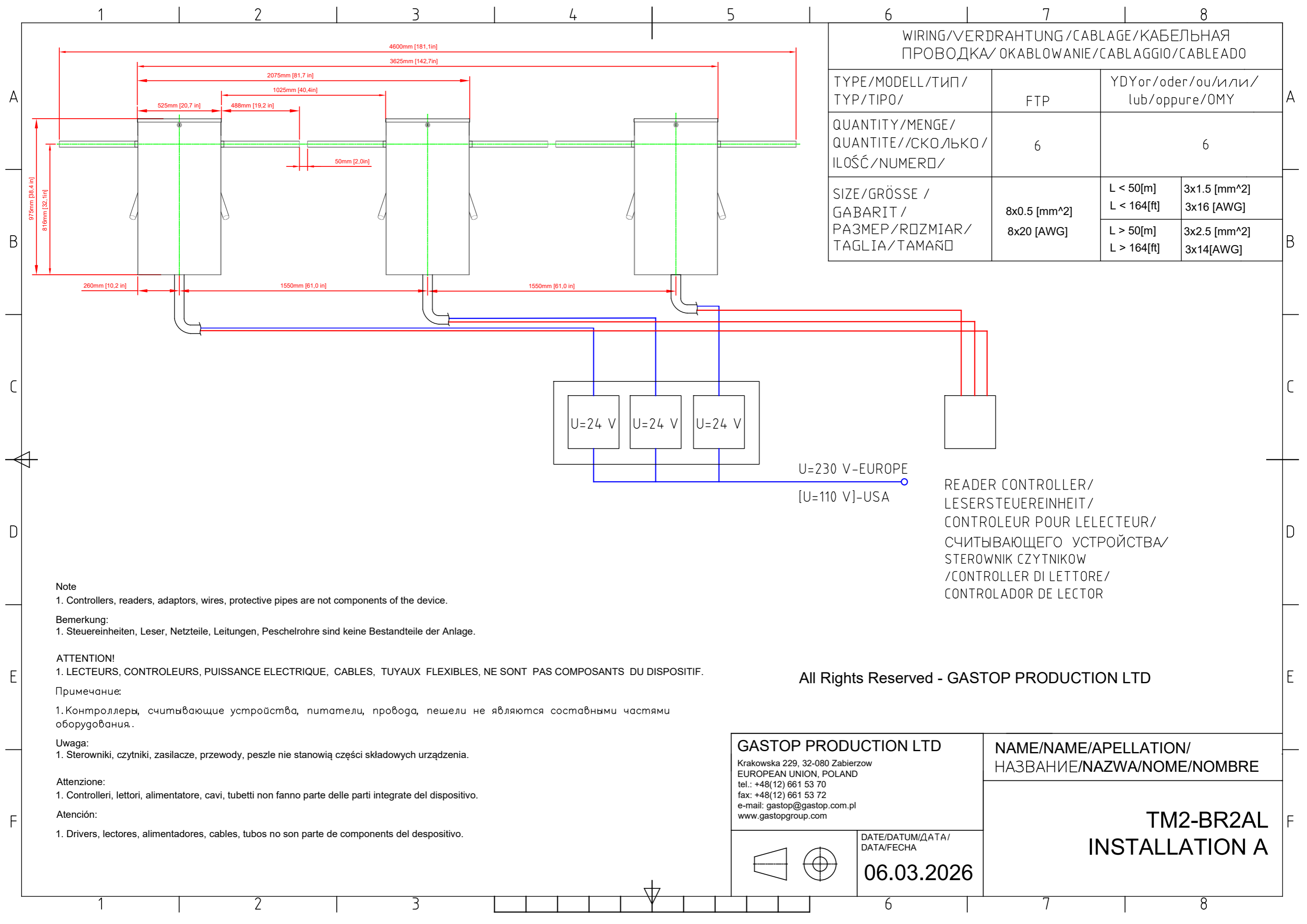

WIRING/VERDRÄHTUNG/САБЛАЖЕ/КАБЕЛЬНАЯ ПРОВОДКА/OKABLOWANIE/CABLAGGIO/CABLEADO		
TYPE/MODELL/ТИП/ TYP/TIPO/	FTP	YDYor/oder/ou/или/ lub/oppure/OMY
QUANTITY/MENGE/ QUANTITE//СКОЛЬКО/ ILOŚĆ/NUMERO/	6	6
SIZE/GRÖSSE / GABARIT / PAZMEP/ROZMIAR/ TAGLIA/TAMAÑO	8x0.5 [mm <sup>2</sup> ]	L < 50[m] L < 164[ft]
	8x20 [AWG]	L > 50[m] L > 164[ft]
		3x1.5 [mm <sup>2</sup> ] 3x16 [AWG]
		3x2.5 [mm <sup>2</sup> ] 3x14[AWG]

**Note**

1. Controllers, readers, adaptors, wires, protective pipes are not components of the device.

**Bemerkung:**

1. Steuereinheiten, Leser, Netzteile, Leitungen, Peschelrohre sind keine Bestandteile der Anlage.

**ATTENTION!**

1. LECTEURS, CONTROLEURS, PUISSANCE ELECTRIQUE, CABLES, TUYAUX FLEXIBLES, NE SONT PAS COMPOSANTS DU DISPOSITIF.

**Примечание:**

1.Контроллеры, считывающие устройства, питатели, провода, пешели не являются составными частями оборудования.

**Uwaga:**

1. Sterowniki, czytniki, zasilacze, przewody, peszle nie stanowią części składowych urządzenia.

**Attenzione:**

1. Controlleri, lettori, alimentatore, cavi, tubetti non fanno parte delle parti integrate del dispositivo.

**Atención:**

1. Drivers, lectores, alimentadores, cables, tubos no son parte de componentes del dispositivo.

READER CONTROLLER/  
LESERSTEUEREINHEIT/  
CONTROLEUR POUR LECTEUR/  
СЧИТЫВАЮЩЕГО УСТРОЙСТВА/  
STEROWNIK CZYTNIKOW  
/CONTROLLER DI LETTORE/  
CONTROLADOR DE LECTOR

All Rights Reserved - GASTOP PRODUCTION LTD

**GASTOP PRODUCTION LTD**

Krakowska 229, 32-080 Zabierzow  
EUROPEAN UNION, POLAND  
tel.: +48(12) 661 53 70  
fax: +48(12) 661 53 72  
e-mail: gastop@gastop.com.pl  
www.gastopgroup.com

NAME/NAME/APELLATION/  
НАЗВАНИЕ/NAZWA/NOME/NOMBRE

**TM2-BR2AL  
INSTALLATION A**

DATE/DATUM/DATA/  
DATA/FECHA

**06.03.2026**

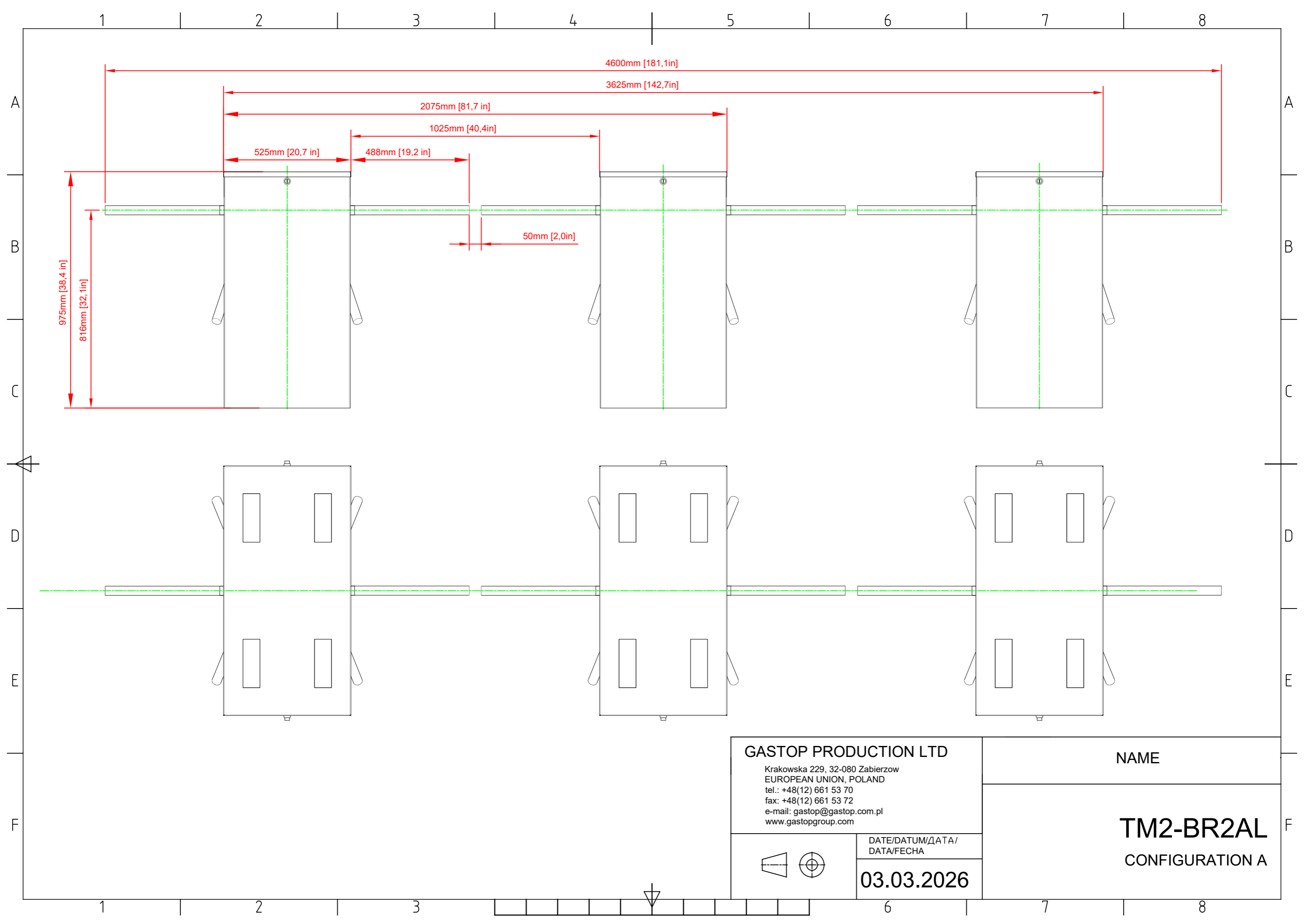

**GASTOP PRODUCTION LTD**  
 Krakowska 229, 32-080 Zabierzow  
 EUROPEAN UNION, POLAND  
 tel.: +48(12) 661 53 70  
 fax: +48(12) 661 53 72  
 e-mail: gastop@gastop.com.pl  
 www.gastopgroup.com

NAME

**TM2-BR2AL**  
 CONFIGURATION A

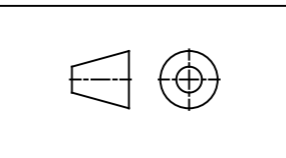

DATE/DATUM/DATA/  
 DATA/FECHA

**03.03.2026**

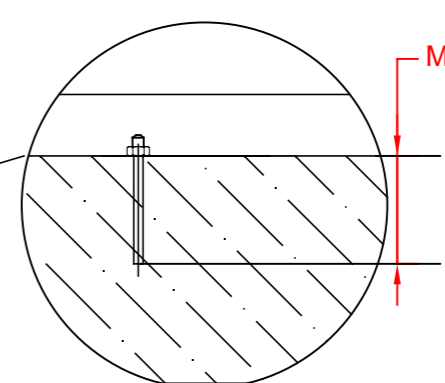
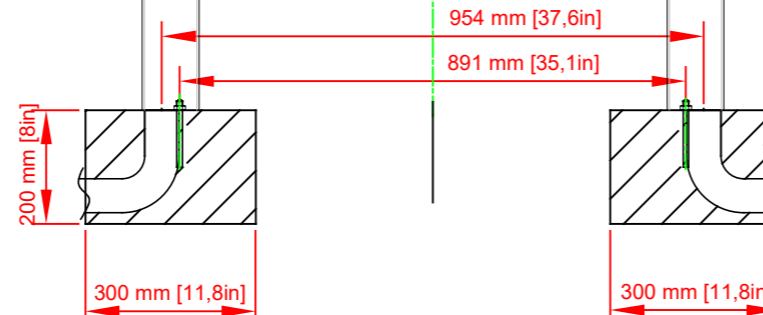
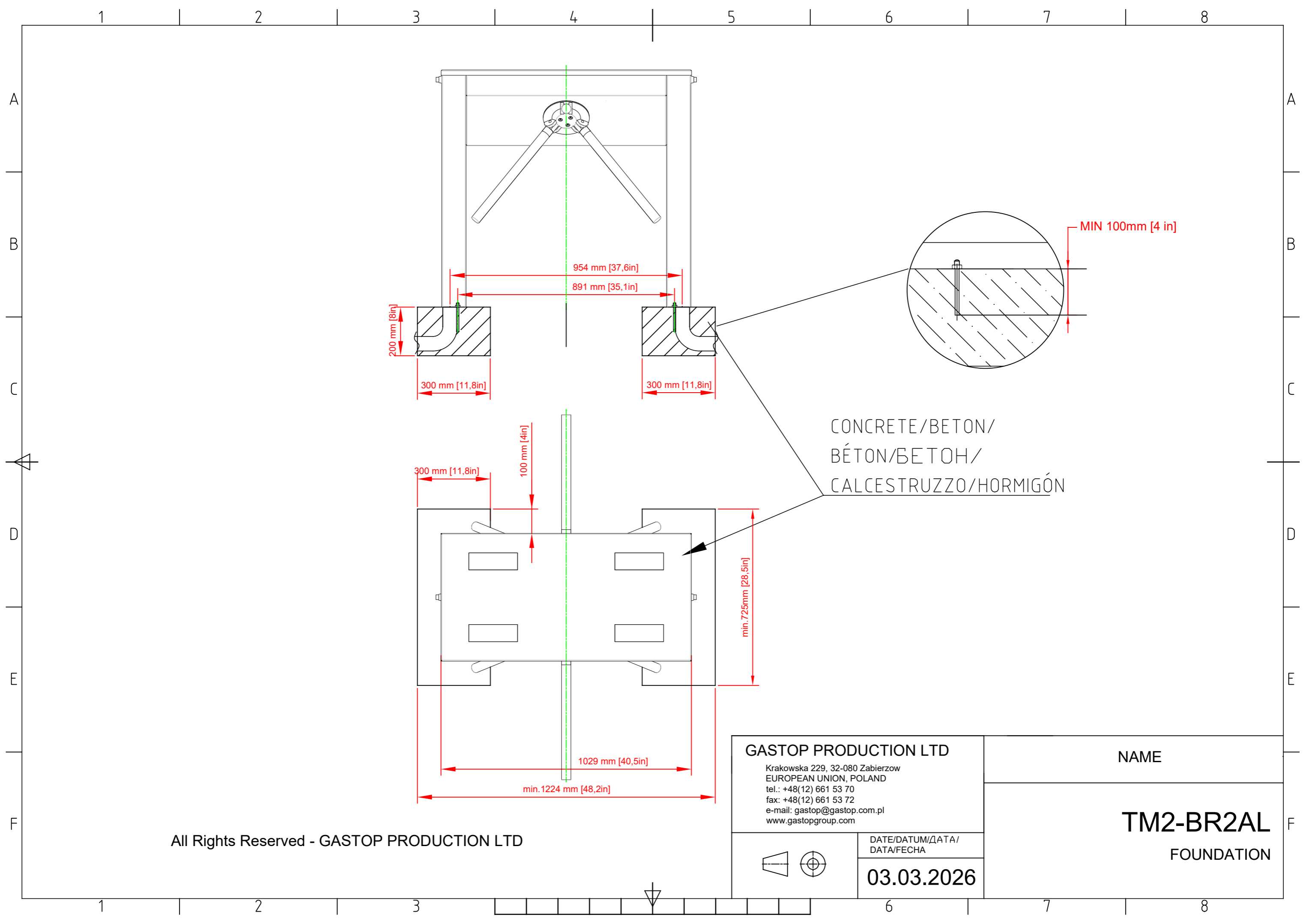

CONCRETE/BETON/  
 BÉTON/BETON/  
 CALCESTRUZZO/HORMIGÓN

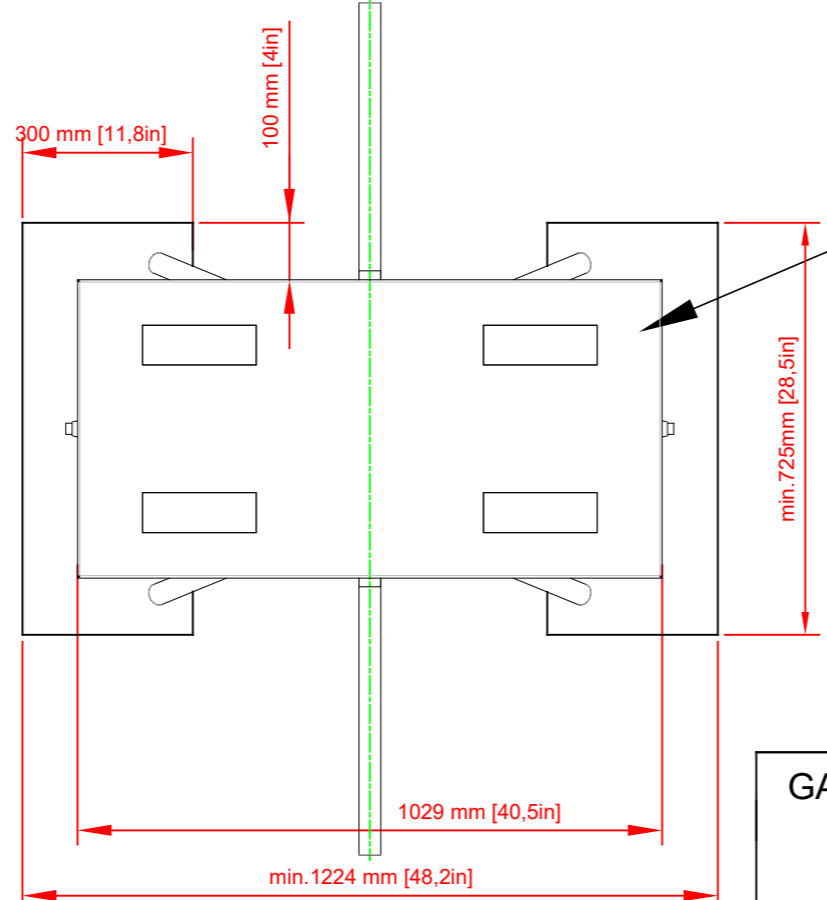

All Rights Reserved - GASTOP PRODUCTION LTD

<b>GASTOP PRODUCTION LTD</b> Krakowska 229, 32-080 Zabierzow EUROPEAN UNION, POLAND tel.: +48(12) 661 53 70 fax: +48(12) 661 53 72 e-mail: gastop@gastop.com.pl www.gastopgroup.com	
	DATE/DATUM/DATA/ DATA/FECHA
	<b>03.03.2026</b>

NAME
<b>TM2-BR2AL</b> FOUNDATION

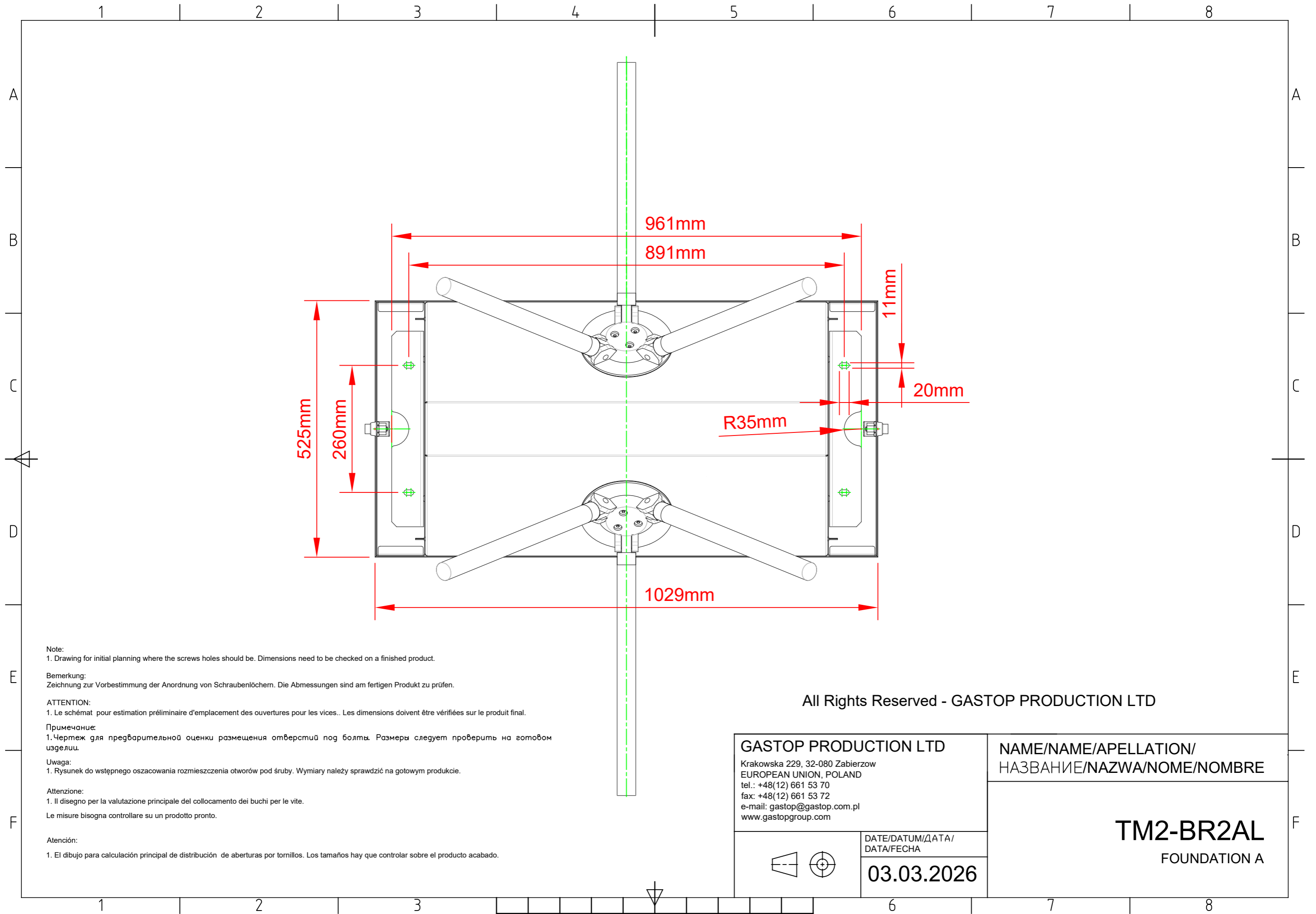

Note:  
1. Drawing for initial planning where the screws holes should be. Dimensions need to be checked on a finished product.

Bemerkung:  
Zeichnung zur Vorbestimmung der Anordnung von Schraubenlöchern. Die Abmessungen sind am fertigen Produkt zu prüfen.

ATTENTION:  
1. Le schémat pour estimation préliminaire d'emplacement des ouvertures pour les vices.. Les dimensions doivent être vérifiées sur le produit final.

Примечание:  
1. Чертеж для предварительной оценки размещения отверстий под болты. Размеры следует проверить на готовом изделии.

Uwaga:  
1. Rysunek do wstępnego oszacowania rozmieszczenia otworów pod śruby. Wymiary należy sprawdzić na gotowym produkcie.

Attenzione:  
1. Il disegno per la valutazione principale del collocamento dei buchi per le vite.

Le misure bisogna controllare su un prodotto pronto.

Atención:  
1. El dibujo para calculación principal de distribución de aberturas por tornillos. Los tamaños hay que controlar sobre el producto acabado.

All Rights Reserved - GASTOP PRODUCTION LTD

**GASTOP PRODUCTION LTD**

Krakowska 229, 32-080 Zabierzow  
EUROPEAN UNION, POLAND  
tel.: +48(12) 661 53 70  
fax: +48(12) 661 53 72  
e-mail: gastop@gastop.com.pl  
www.gastopgroup.com

NAME/NAME/APELLATION/  
НАЗВАНИЕ/NAZWA/NOME/NOMBRE

**TM2-BR2AL**  
FOUNDATION A

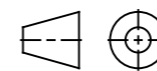

DATE/DATUM/DATE/  
DATA/FECHA

**03.03.2026**

RIGHT DIRECTION/RECHTE RICHTUNG/DROIT/  
ПРАВОЕ НАПРАВЛЕНИЕ/KIERUNEK PRAWY/  
DIREZIONE DESTRA/DIRECCIÓN DERECHA

LEFT DIRECTION/LINKE RICHTUNG/GAUCHE  
/ЛЕВОЕ направление /KIERUNEK  
LEWY/DIREZIONE SINISTRA/DIRECCIÓN IZQUIERDA

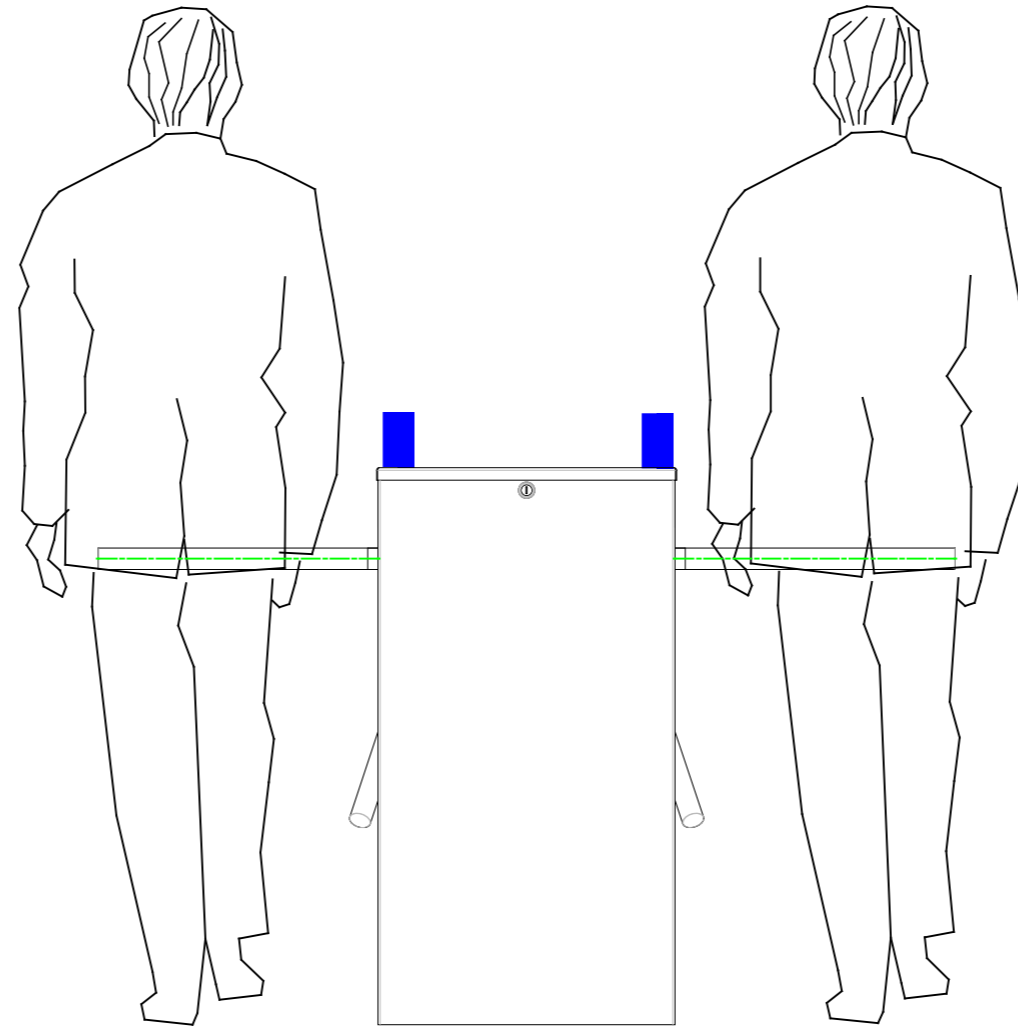

All Rights Reserved - GASTOP PRODUCTION LTD

**GASTOP PRODUCTION LTD**

Krakowska 229, 32-080 Zabierzow  
EUROPEAN UNION, POLAND  
tel.: +48(12) 661 53 70  
fax: +48(12) 661 53 72  
e-mail: gastop@gastop.com.pl  
www.gastopgroup.com

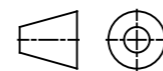

DATE/DATUM/ДАТА/  
DATA/FECHA

**03.03.2026**

NAME

**TM2-BR2AL**

INFORMATION

1 2 3 4 5 6 7 8

A

A

B

B

C

C

D

D

E

E

F

F

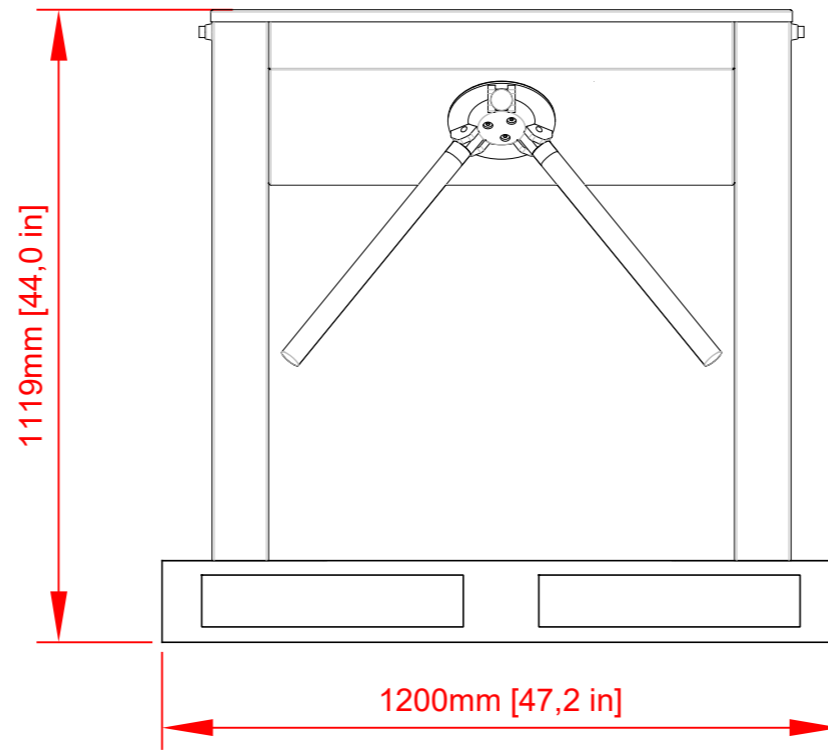

1 X EPAL

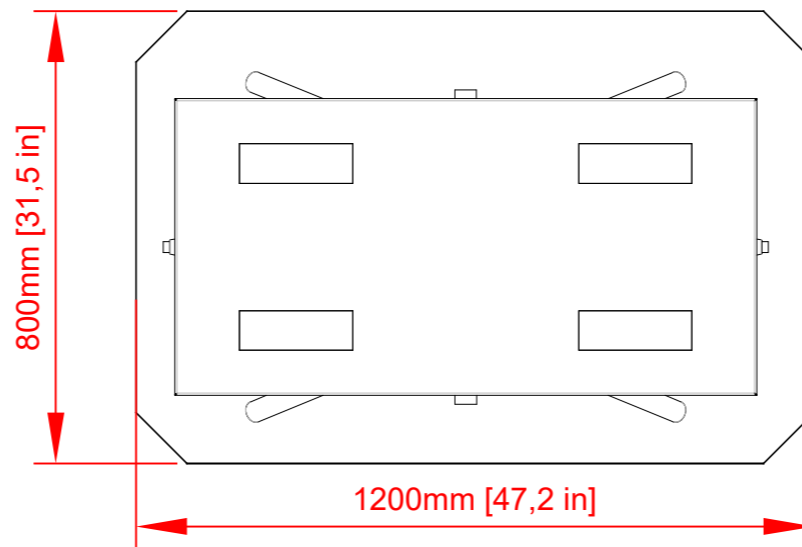

1 X TM2-BR2AL

All Rights Reserved - GASTOP PRODUCTION LTD

**GASTOP PRODUCTION LTD**

Krakowska 229, 32-080 Zabierzow  
EUROPEAN UNION, POLAND  
tel.: +48(12) 661 53 70  
fax: +48(12) 661 53 72  
e-mail: gastop@gastop.com.pl  
www.gastopgroup.com

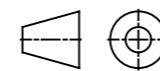

DATE/DATUM/DATA/  
DATA/FECHA

**03.03.2026**

NAME

**TM2-BR2AL**

PREPARATION FOR TRANSPORT

1 2 3 4 5 6 7 8