



# T-BR2AL

TECHNICAL DRAWINGS

ALL RIGHTS RESERVED BY GASTOP PRODUCTION LTD

03.2026

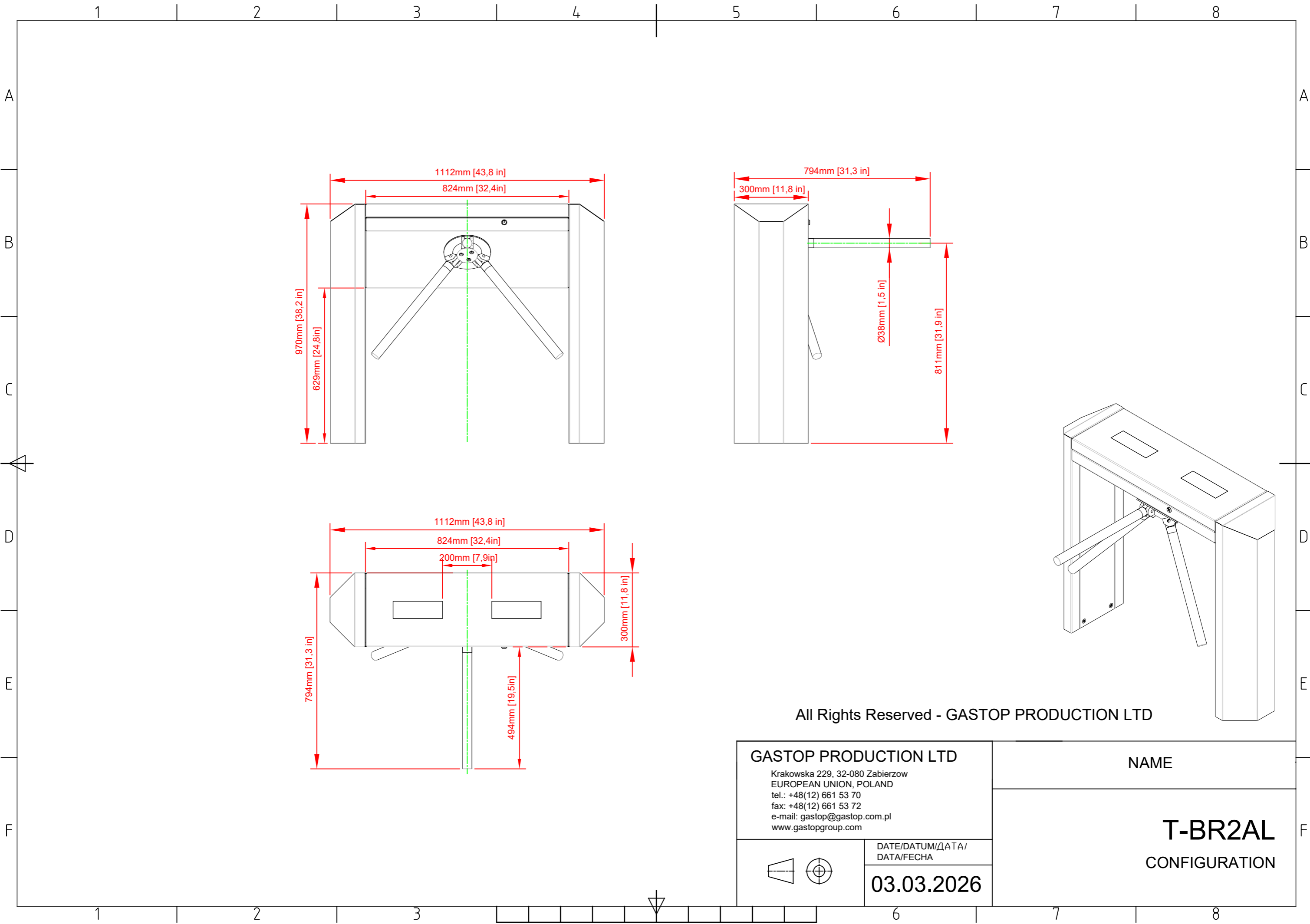

All Rights Reserved - GASTOP PRODUCTION LTD

<b>GASTOP PRODUCTION LTD</b> Krakowska 229, 32-080 Zabierzow EUROPEAN UNION, POLAND tel.: +48(12) 661 53 70 fax: +48(12) 661 53 72 e-mail: gastop@gastop.com.pl www.gastopgroup.com	
	DATE/DATUM/DATA/ DATA/FECHA
	<b>03.03.2026</b>

NAME
<b>T-BR2AL</b> CONFIGURATION

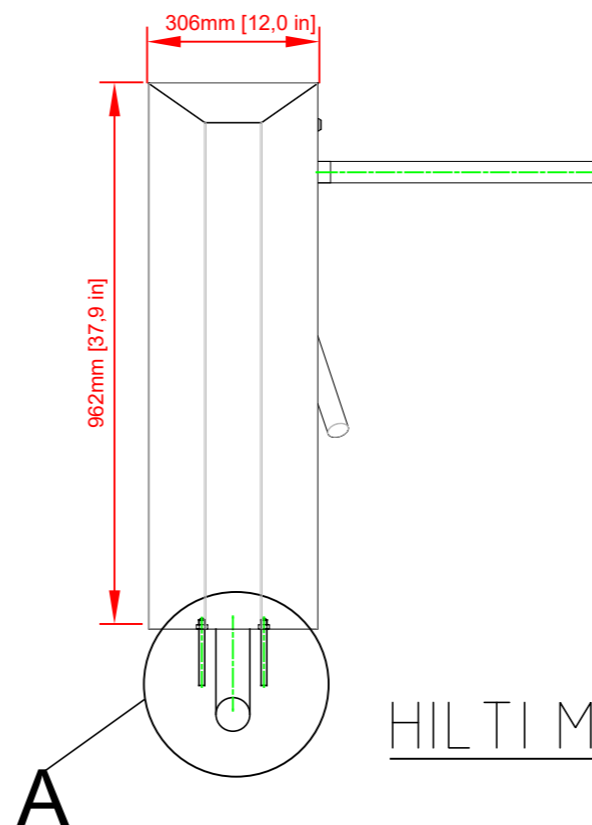
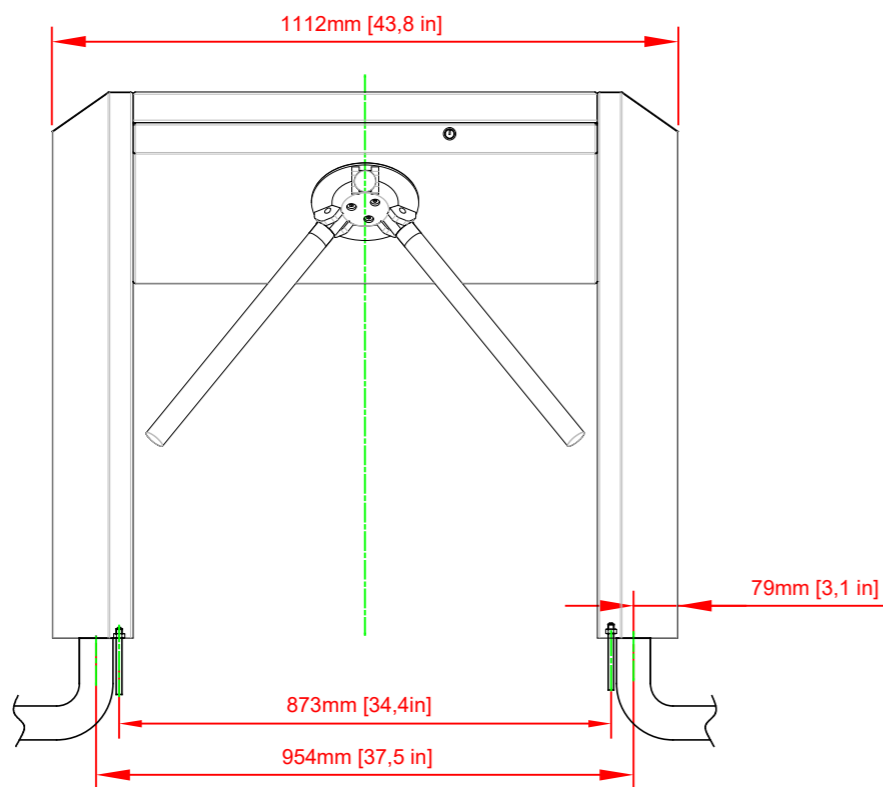

DETAIL//DÉTAIL/ДЕТАЛИ/  
SZCZEGÓŁ /DETTAGLIO/DETALLE

A

HILTI M 10

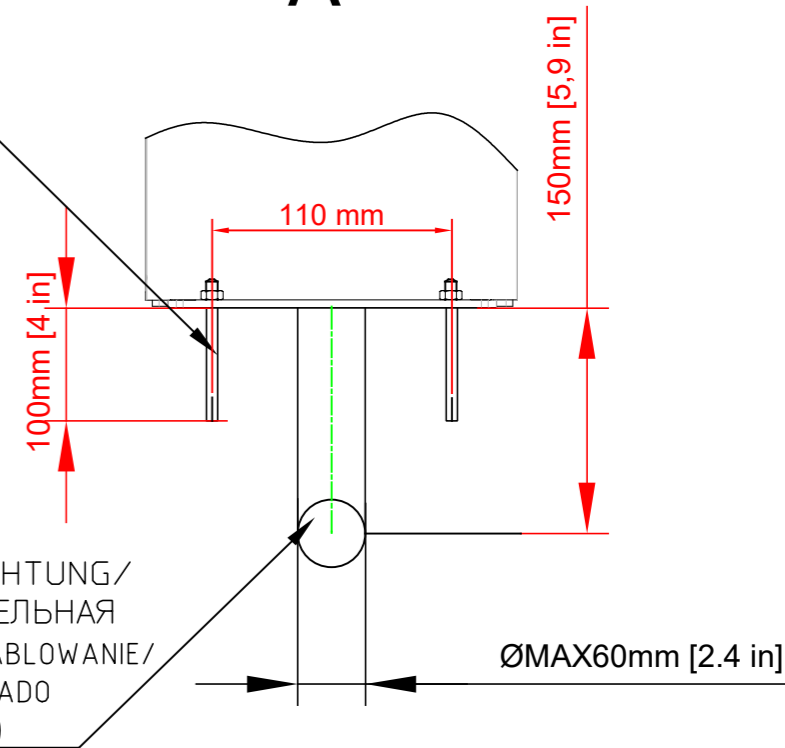

WIRING/VERDRAHTUNG/  
CABLAGE / КАБЕЛЬНАЯ  
ПРОВОДКА/OKABLOWANIE/  
CABLAGGIO/CABLEADO  
(MAX Ø60mm/2,4in)

Note

1. Controllers, readers, adaptors, wires, protective pipes are not components of the device.

Bemerkung:

1. Steuereinheiten, Leser, Netzteile, Leitungen, Peschelrohre sind keine Bestandteile der Anlage.

ATTENTION!

1. LECTEURS, CONTROLEURS, PUISSANCE ELECTRIQUE, CABLES, TUYAUX FLEXIBLES, NE SONT PAS COMPOSANTS DU DISPOSITIF.

Примечание:

1. Контроллеры, считывающие устройства, питатели, провода, пешели не являются составными частями оборудования.

Uwaga:

1. Sterowniki, czytniki, zasilacze, przewody, peszle nie stanowią części składowych urządzenia.

Attenzione:

1. Controlleri, lettori, alimentatore, cavi, tubetti non fanno parte delle parti integrate del dispositivo.

Atención:

1. Drivers, lectores, alimentadores, cables, tubos no son parte de componentes del dispositivo.

All Rights Reserved - GASTOP PRODUCTION LTD

<b>GASTOP PRODUCTION LTD</b> Krakowska 229, 32-080 Zabierzow EUROPEAN UNION, POLAND tel.: +48(12) 661 53 70 fax: +48(12) 661 53 72 e-mail: gastop@gastop.com.pl www.gastopgroup.com	NAME
	T-BR2AL INSTALATION
	DATE/DATUM/ДАТА/ DATA/FECHA
03.03.2026	

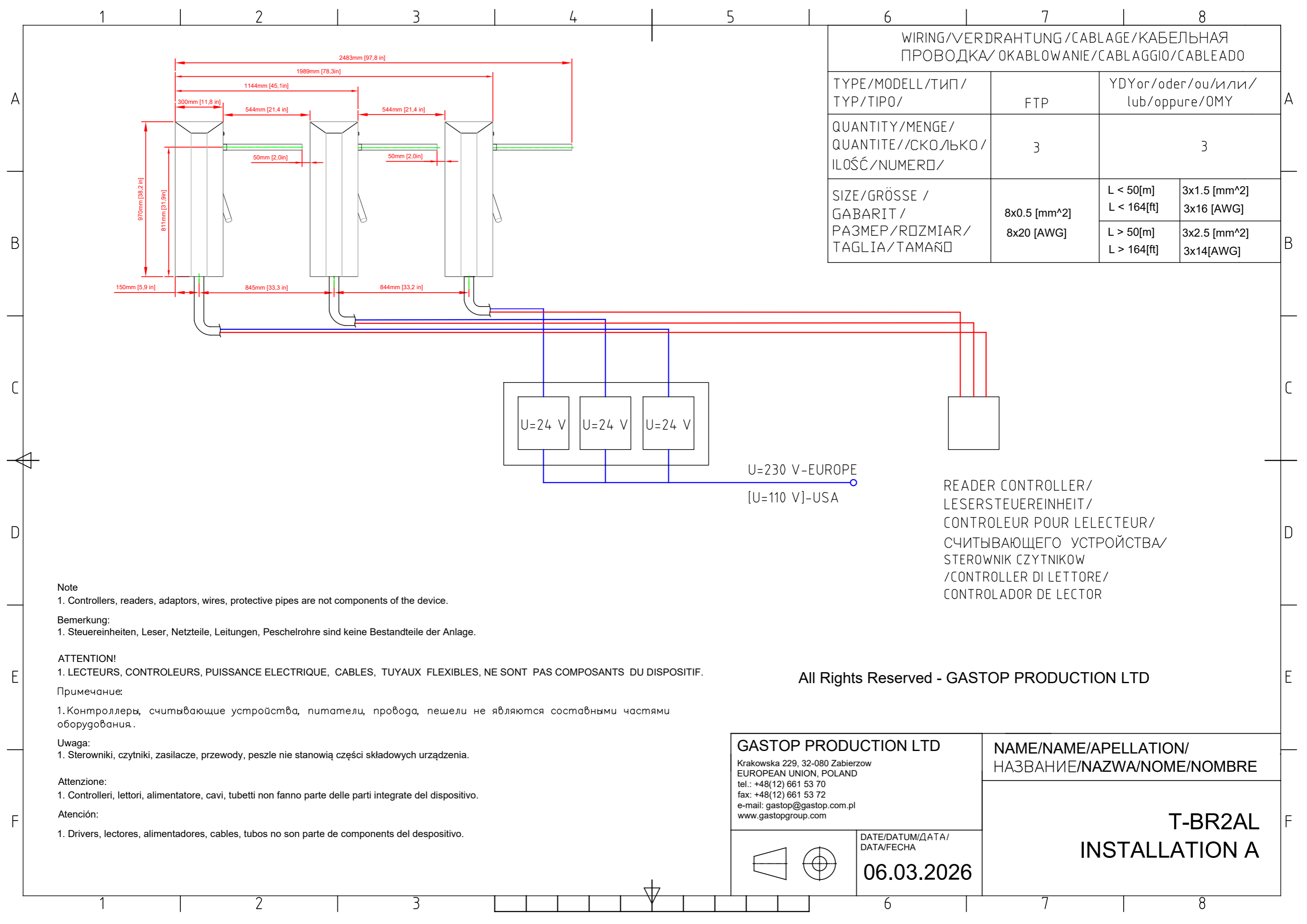

WIRING/VERDRAHTUNG /CABLAGE/КАБЕЛЬНАЯ ПРОВОДКА/OKABLOWANIE/CABLAGGIO/CABLEADO		
TYPE/MODELL/ТИП/ TYP/TIPO/	FTP	YDYor/oder/ou/или/ lub/oppure/OMY
QUANTITY/MENGE/ QUANTITE//СКОЛЬКО/ ILOŚĆ/NUMERO/	3	3
SIZE/GRÖSSE / GABARIT / РАЗМЕР/ROZMIAR/ TAGLIA/TAMAÑO	8x0.5 [mm <sup>2</sup> ]	L < 50[m] L < 164[ft]
	8x20 [AWG]	L > 50[m] L > 164[ft]
		3x1.5 [mm <sup>2</sup> ] 3x16 [AWG] 3x2.5 [mm <sup>2</sup> ] 3x14[AWG]

**Note**

1. Controllers, readers, adaptors, wires, protective pipes are not components of the device.

**Bemerkung:**

1. Steuereinheiten, Leser, Netzteile, Leitungen, Peschelrohre sind keine Bestandteile der Anlage.

**ATTENTION!**

1. LECTEURS, CONTROLEURS, PUISSANCE ELECTRIQUE, CABLES, TUYAUX FLEXIBLES, NE SONT PAS COMPOSANTS DU DISPOSITIF.

**Примечание:**

1. Контроллеры, считывающие устройства, питатели, провода, пешели не являются составными частями оборудования.

**Uwaga:**

1. Sterowniki, czytniki, zasilacze, przewody, peszle nie stanowią części składowych urządzenia.

**Attenzione:**

1. Controlleri, lettori, alimentatore, cavi, tubetti non fanno parte delle parti integrate del dispositivo.

**Atención:**

1. Drivers, lectores, alimentadores, cables, tubos no son parte de componentes del dispositivo.

U=230 V-EUROPE  
[U=110 V]-USA

READER CONTROLLER/  
LESERSTEUEREINHEIT/  
CONTROLEUR POUR LELECTEUR/  
СЧИТЫВАЮЩЕГО УСТРОЙСТВА/  
STEROWNIK CZYTNIKOW  
/CONTROLLER DI LETTORE/  
CONTROLADOR DE LECTOR

All Rights Reserved - GASTOP PRODUCTION LTD

**GASTOP PRODUCTION LTD**

Krakowska 229, 32-080 Zabierzow  
EUROPEAN UNION, POLAND  
tel.: +48(12) 661 53 70  
fax: +48(12) 661 53 72  
e-mail: gastop@gastop.com.pl  
www.gastopgroup.com

NAME/NAME/APELLATION/  
НАЗВАНИЕ/NAZWA/NOME/NOMBRE

**T-BR2AL  
INSTALLATION A**

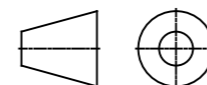

DATE/DATUM/DATA/  
DATA/FECHA

**06.03.2026**

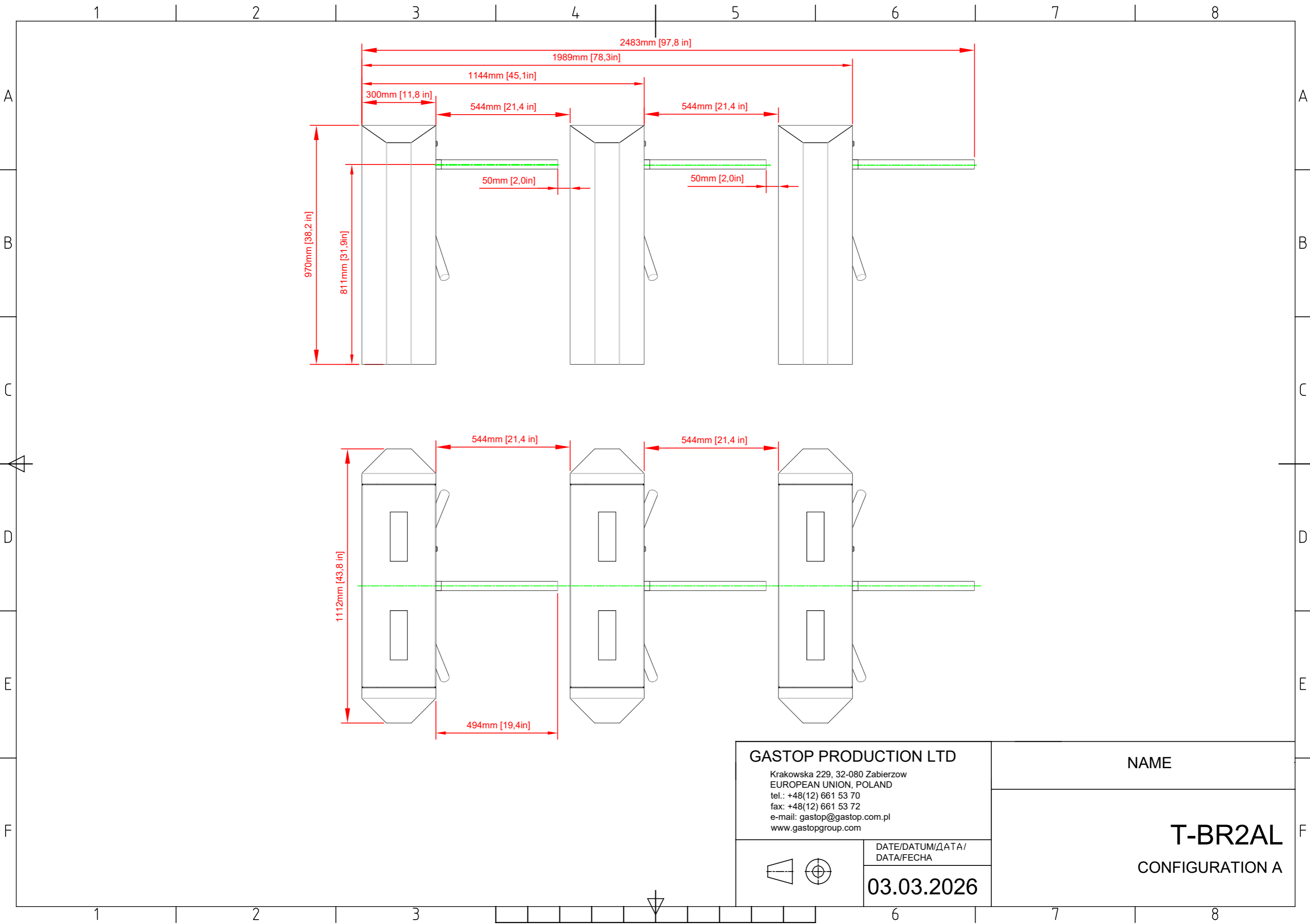

<b>GASTOP PRODUCTION LTD</b>	
Krakowska 229, 32-080 Zabierzow EUROPEAN UNION, POLAND tel.: +48(12) 661 53 70 fax: +48(12) 661 53 72 e-mail: gastop@gastop.com.pl www.gastopgroup.com	
	DATE/DATUM/DATA/ DATA/FECHA
	<b>03.03.2026</b>

NAME
<b>T-BR2AL</b> CONFIGURATION A

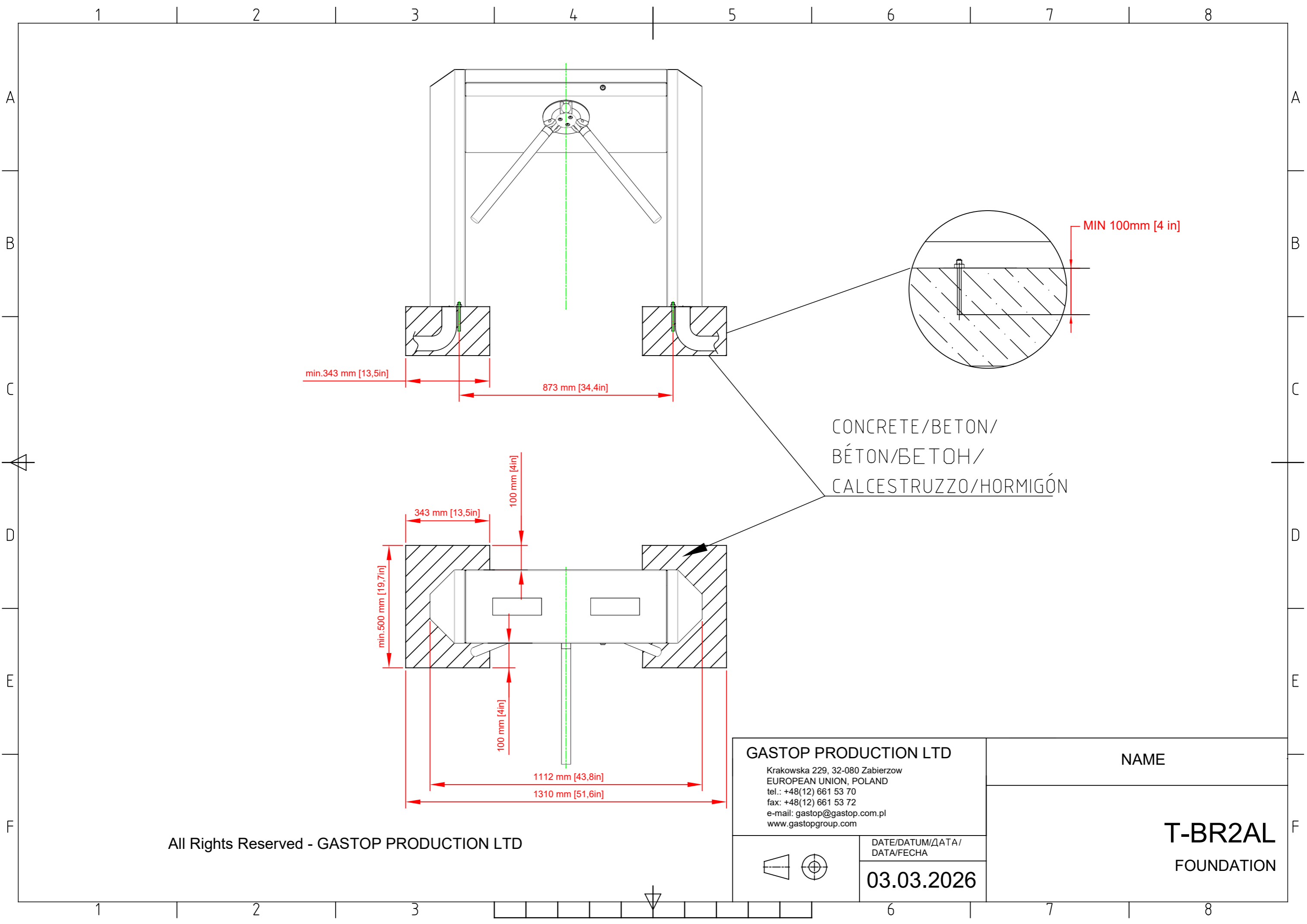

All Rights Reserved - GASTOP PRODUCTION LTD

**GASTOP PRODUCTION LTD**  
 Krakowska 229, 32-080 Zabierzow  
 EUROPEAN UNION, POLAND  
 tel.: +48(12) 661 53 70  
 fax: +48(12) 661 53 72  
 e-mail: gastop@gastop.com.pl  
 www.gastopgroup.com

DATE/DATUM/DATA/  
DATA/FECHA  
**03.03.2026**

NAME
<b>T-BR2AL</b> FOUNDATION

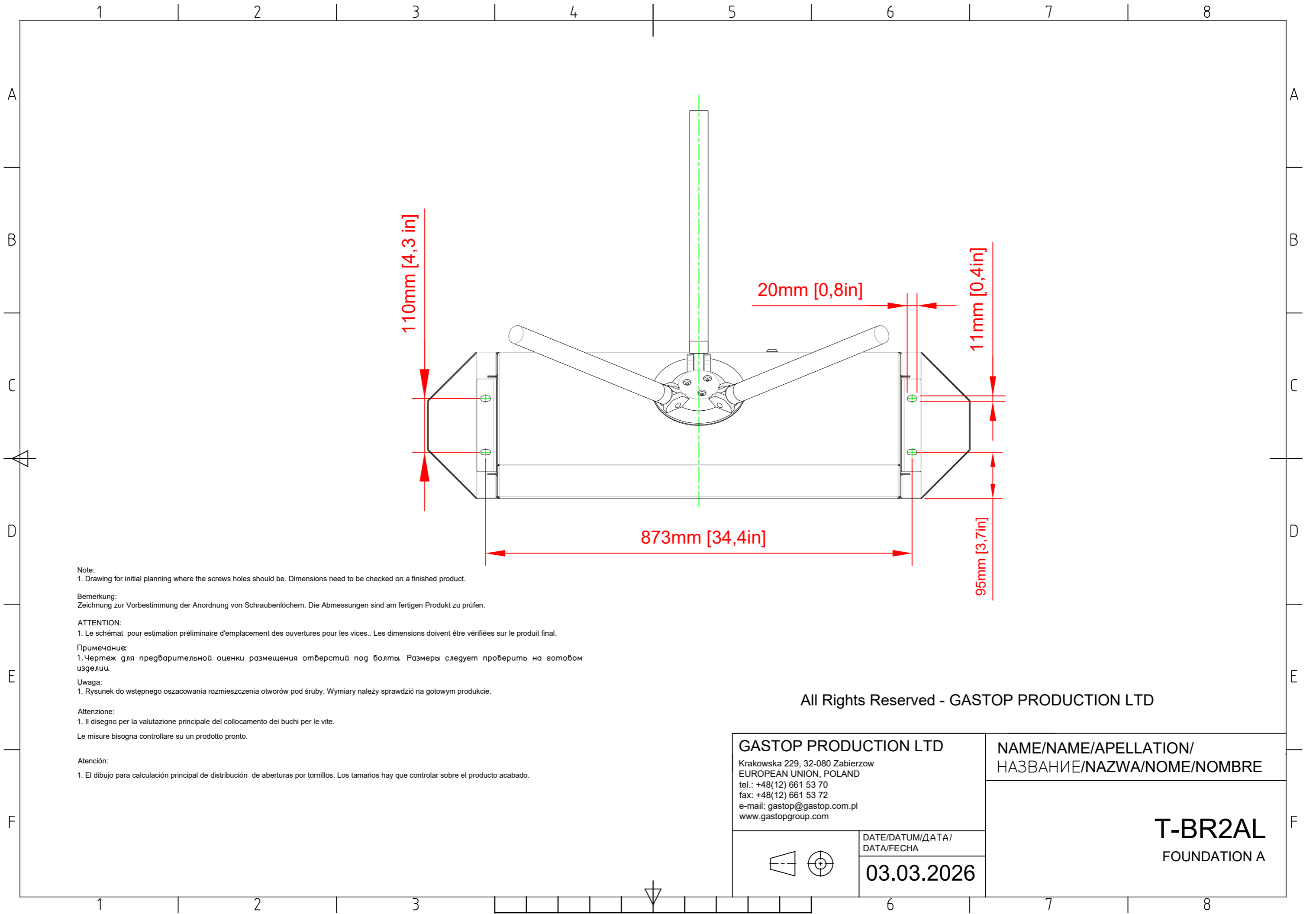

Note:  
1. Drawing for initial planning where the screws holes should be. Dimensions need to be checked on a finished product.

Bemerkung:  
Zeichnung zur Vorbestimmung der Anordnung von Schraubenlöchern. Die Abmessungen sind am fertigen Produkt zu prüfen.

ATTENTION:  
1. Le schémat pour estimation préliminaire d'emplacement des ouvertures pour les vices.. Les dimensions doivent être vérifiées sur le produit final.

Примечание:  
1. Чертеж для предварительной оценки размещения отверстий под болты. Размеры следует проверить на готовом изделии.

Uwaga:  
1. Rysunek do wstępnego oszacowania rozmieszczenia otworów pod śruby. Wymiary należy sprawdzić na gotowym produkcie.

Attenzione:  
1. Il disegno per la valutazione principale del collocamento dei buchi per le viti.

Le misure bisogna controllare su un prodotto pronto.

Atención:  
1. El dibujo para calculación principal de distribución de aberturas por tornillos. Los tamaños hay que controlar sobre el producto acabado.

All Rights Reserved - GASTOP PRODUCTION LTD

<b>GASTOP PRODUCTION LTD</b> Krakowska 229, 32-080 Zabierzow EUROPEAN UNION, POLAND tel.: +48(12) 661 53 70 fax: +48(12) 661 53 72 e-mail: gastop@gastop.com.pl www.gastopgroup.com		NAME/NAME/APELLATION/ НАЗВАНИЕ/NAZWA/NOME/NOMBRE
		<b>T-BR2AL</b> FOUNDATION A
DATE/DATUM/ДАТА/ DATA/FECHA <b>03.03.2026</b>		

1

2

3

4

5

6

7

8

A

A

LEFT DIRECTION/LINKE RICHTUNG/GAUCHE  
 /ЛЕВОЕ направление /KIERUNEK  
 LEWY/DIREZIONE SINISTRA/DIRECCIÓN IZQUIERDA

RIGHT DIRECTION/RECHTE RICHTUNG/DROIT/  
 ПРАВОЕ НАПРАВЛЕНИЕ/KIERUNEK PRAWY/  
 DIREZIONE DESTRA/DIRECCIÓN DERECHA

B

B

C

C

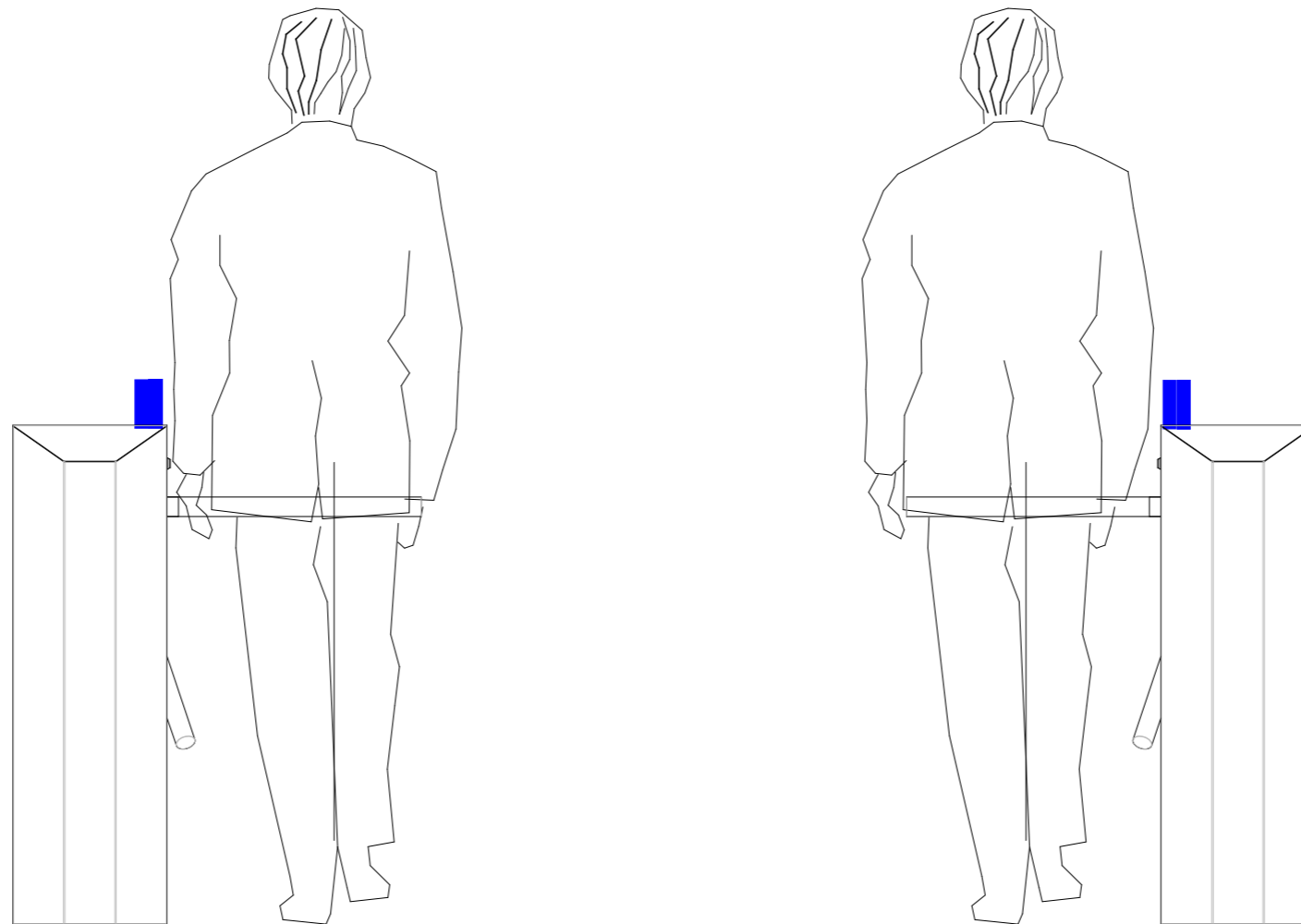

D

D

E

E

F

F

All Rights Reserved - GASTOP PRODUCTION LTD

**GASTOP PRODUCTION LTD**

Krakowska 229, 32-080 Zabierzow  
 EUROPEAN UNION, POLAND  
 tel.: +48(12) 661 53 70  
 fax: +48(12) 661 53 72  
 e-mail: gastop@gastop.com.pl  
 www.gastopgroup.com



DATE/DATUM/DATA/  
 DATA/FECHA

03.03.2026

NAME

**T-BR2AL**  
 INFORMATION

1

2

3

6

7

8

1 2 3 4 5 6 7 8

A

B

C

D

E

F

A

B

C

D

E

F

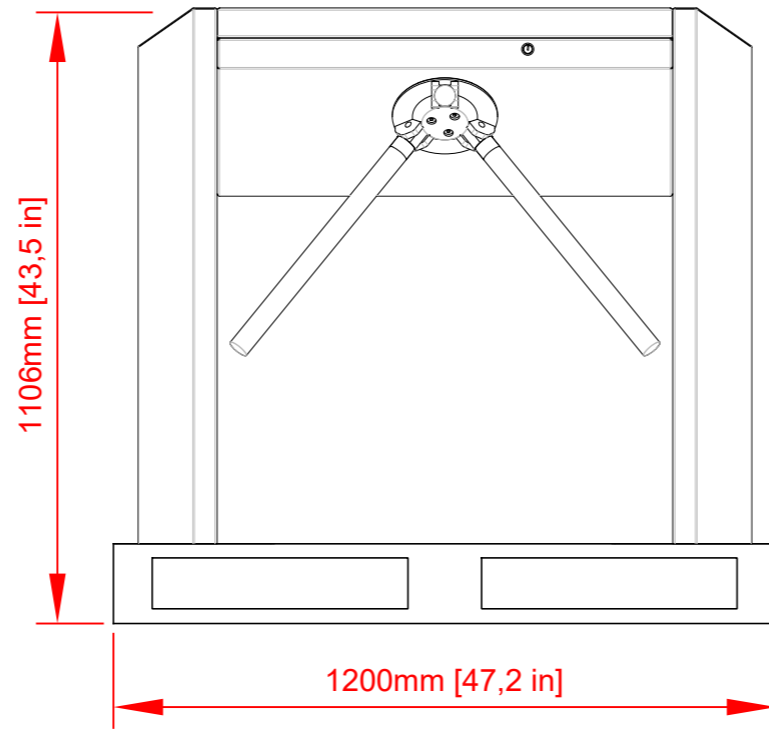

1 X EPAL

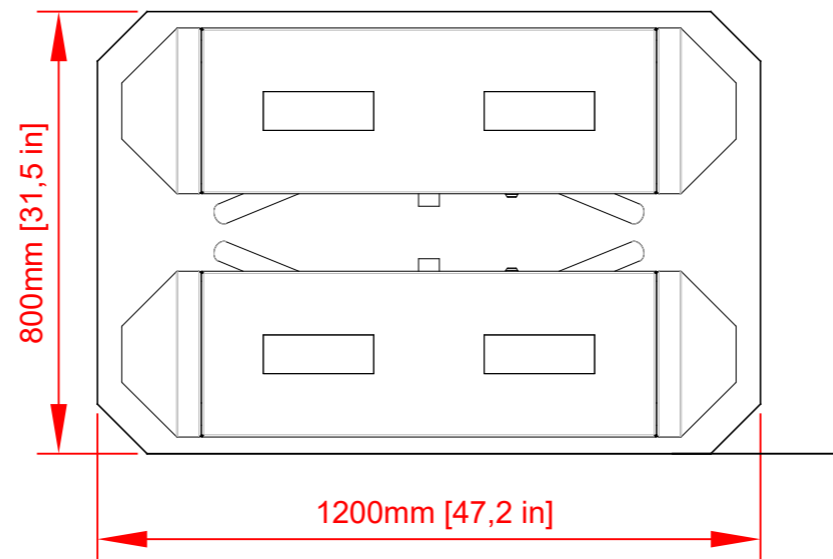

2 X T-BR2AL

All Rights Reserved - GASTOP PRODUCTION LTD

**GASTOP PRODUCTION LTD**

Krakowska 229, 32-080 Zabierzow  
EUROPEAN UNION, POLAND  
tel.: +48(12) 661 53 70  
fax: +48(12) 661 53 72  
e-mail: gastop@gastop.com.pl  
www.gastopgroup.com

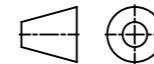

DATE/DATUM/DATA/  
DATA/FECHA

**03.03.2026**

NAME

**T-BR2AL**

PREPARATION FOR TRANSPORT

1 2 3 4 5 6 7 8