



STI2-BR2AL

TECHNICAL DRAWINGS

ALL RIGHTS RESERVED BY GASTOP PRODUCTION LTD

03.2026

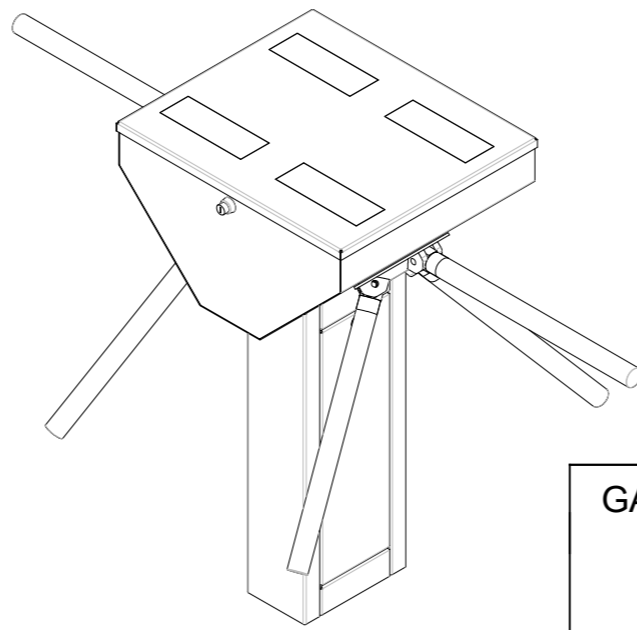
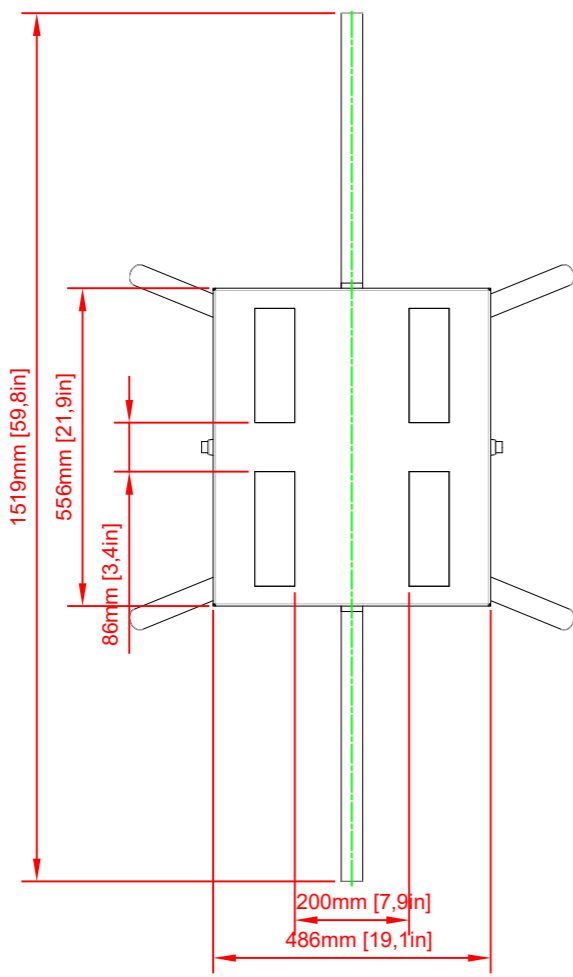
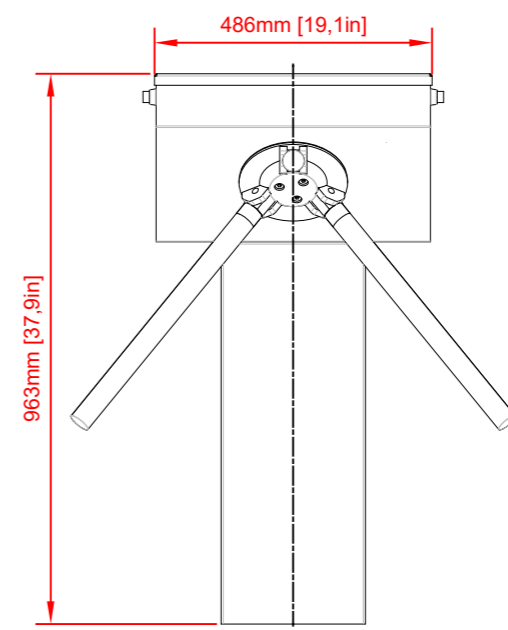
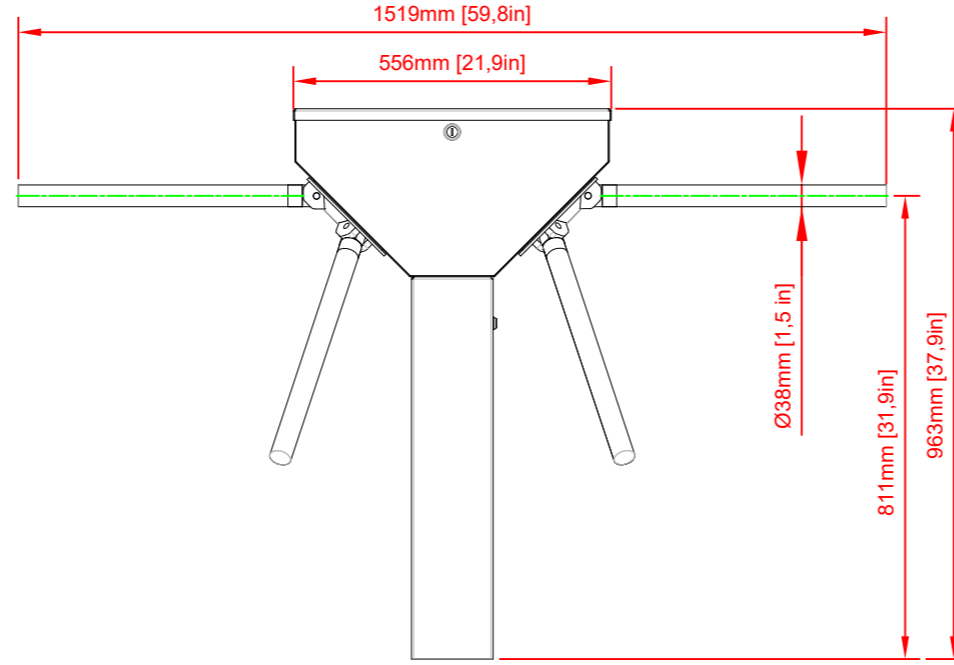
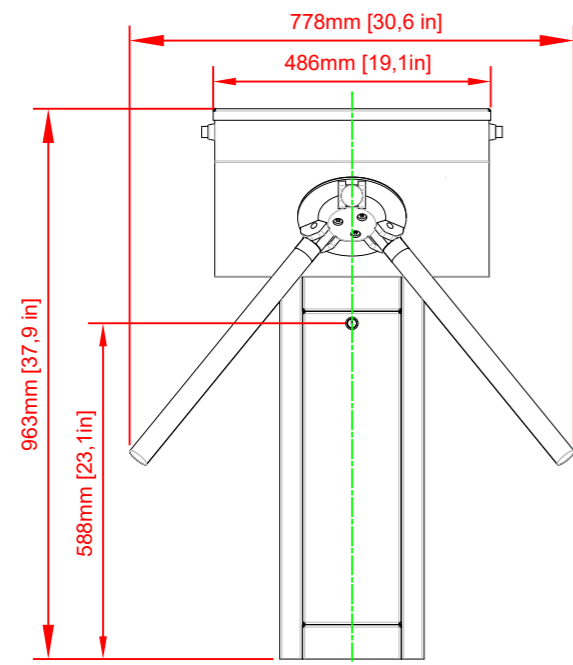

All Rights Reserved - GASTOP PRODUCTION LTD

GASTOP PRODUCTION LTD	
Krakowska 229, 32-080 Zabierzow EUROPEAN UNION, POLAND tel.: +48(12) 661 53 70 fax: +48(12) 661 53 72 e-mail: gastop@gastop.com.pl www.gastopgroup.com	
	DATE/DATUM/DATA/ DATA/FECHA
	04.03.2026

NAME
STI2-BR2AL
CONFIGURATION

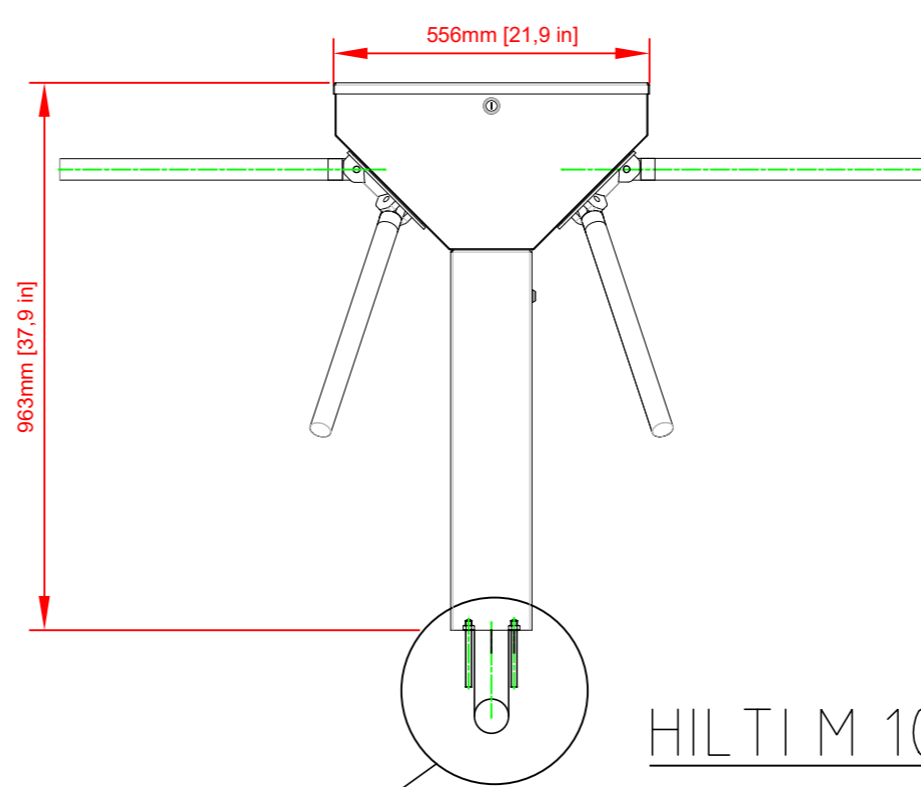
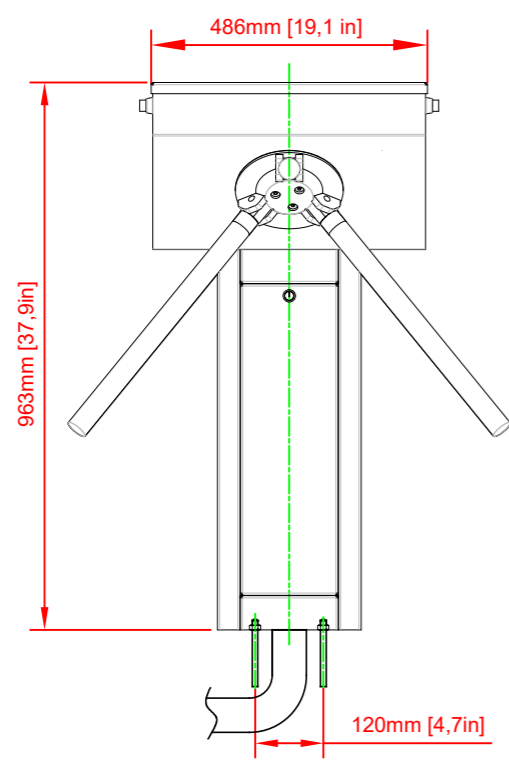

DETAIL//DÉTAIL/ДЕТАЛИ/
SZCZEGÓŁ /DETTAGLIO/DETALLE

A

HILTI M 10

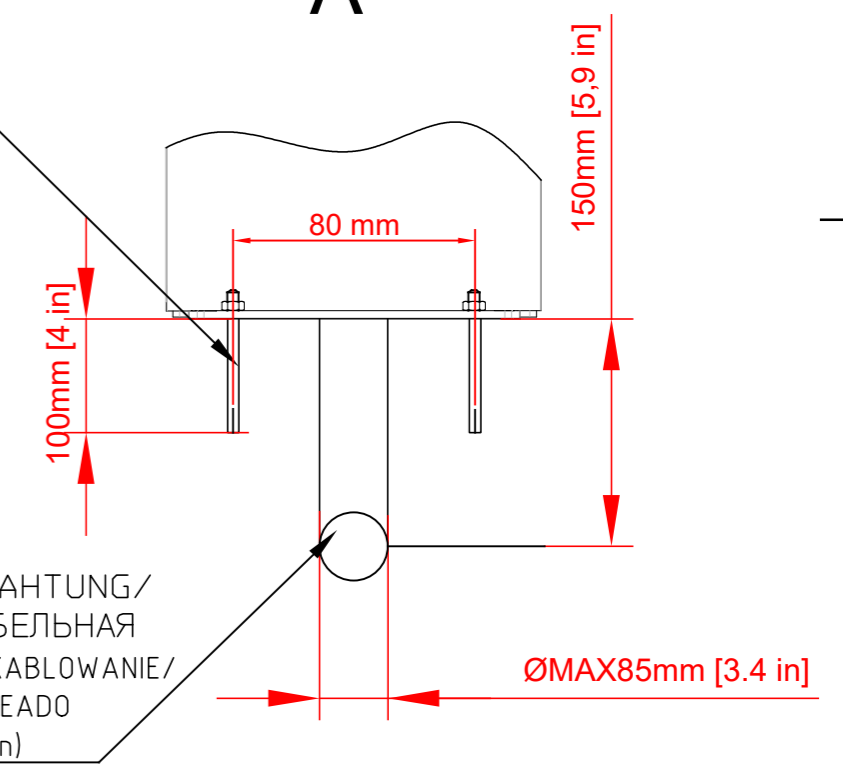

WIRING/VERDRAHTUNG/
CABLAGE / КАБЕЛЬНАЯ
ПРОВОДКА/OKABLOWANIE/
CABLAGGIO/CABLEADO
(MAX Ø60mm/2,4in)

Note

1. Controllers, readers, adaptors, wires, protective pipes are not components of the device.

Bemerkung:

1. Steuereinheiten, Leser, Netzteile, Leitungen, Peschelrohre sind keine Bestandteile der Anlage.

ATTENTION!

1. LECTEURS, CONTROLEURS, PUISSANCE ELECTRIQUE, CABLES, TUYAUX FLEXIBLES, NE SONT PAS COMPOSANTS DU DISPOSITIF.

Примечание:

1. Контроллеры, считывающие устройства, питатели, провода, пешели не являются составными частями оборудования.

Uwaga:

1. Sterowniki, czytniki, zasilacze, przewody, peszle nie stanowią części składowych urządzenia.

Attenzione:

1. Controlleri, lettori, alimentatore, cavi, tubetti non fanno parte delle parti integrate del dispositivo.

Atención:

1. Drivers, lectores, alimentadores, cables, tubos no son parte de componentes del dispositivo.

All Rights Reserved - GASTOP PRODUCTION LTD

GASTOP PRODUCTION LTD Krakowska 229, 32-080 Zabierzow EUROPEAN UNION, POLAND tel.: +48(12) 661 53 70 fax: +48(12) 661 53 72 e-mail: gastop@gastop.com.pl www.gastopgroup.com	NAME
	STI2-BR2AL INSTALATION
	DATE/DATUM/DATA/ DATA/FECHA 04.03.2026

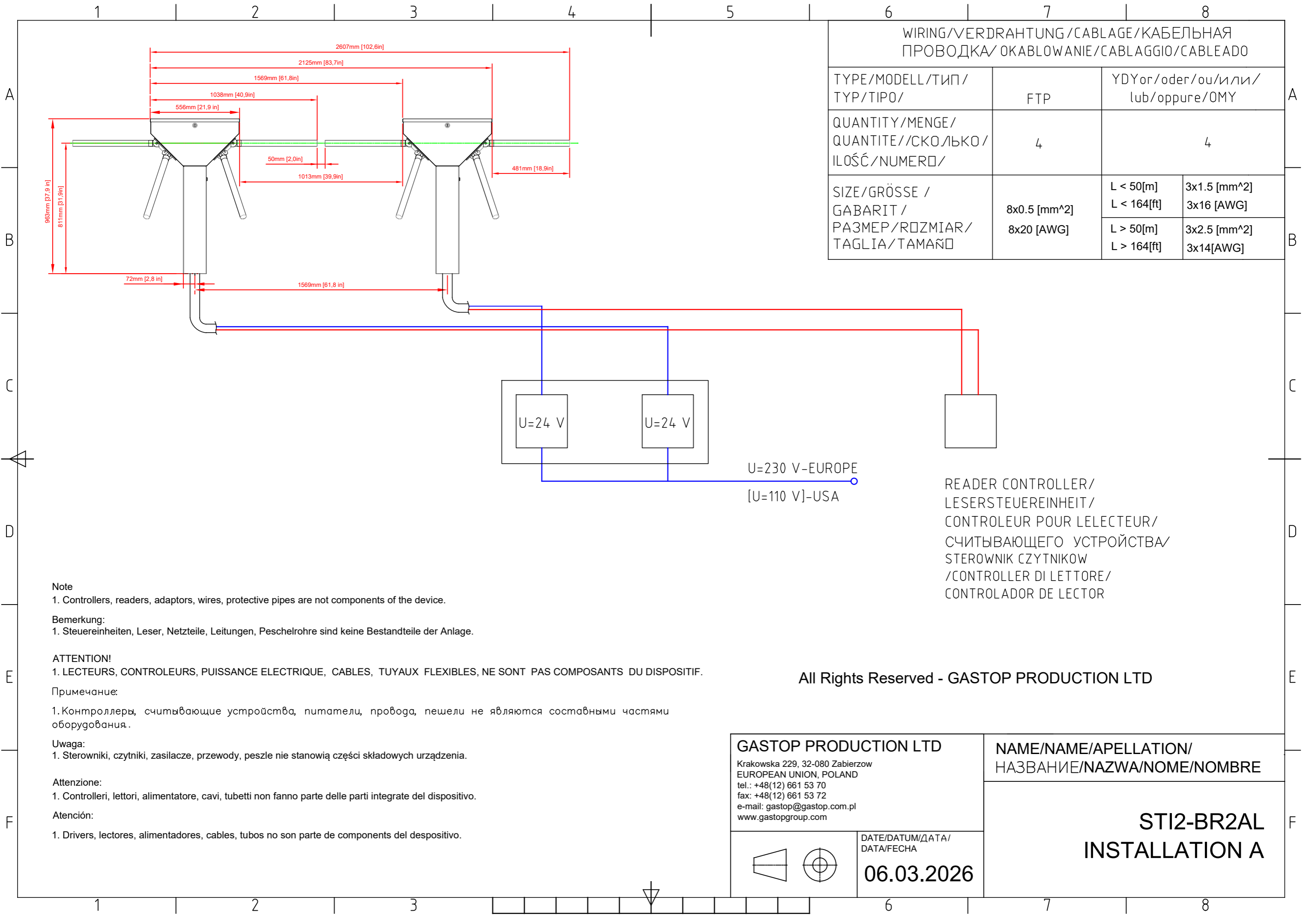

WIRING/VERDRÄHTUNG/CABLAGE/КАБЕЛЬНАЯ ПРОВОДКА/OKABLOWANIE/CABLAGGIO/CABLEADO		
TYPE/MODELL/ТИП/ТИП/ТИПО/	FTP	YDYor/oder/ou/или/lub/oppure/OMY
QUANTITY/MENGE/QUANTITE//СКОЛЬКО/ILÓŚĆ/NUMERO/	4	4
SIZE/GRÖSSE /GABARIT /PAZMEP/ROZMIAR/TAGLIA/TAMAÑO	8x0.5 [mm ²]	L < 50[m] L < 164[ft]
	8x20 [AWG]	L > 50[m] L > 164[ft]
		3x1.5 [mm ²] 3x16 [AWG]
		3x2.5 [mm ²] 3x14[AWG]

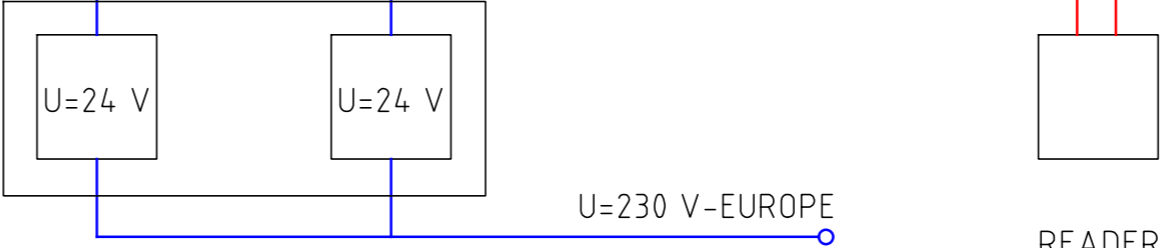
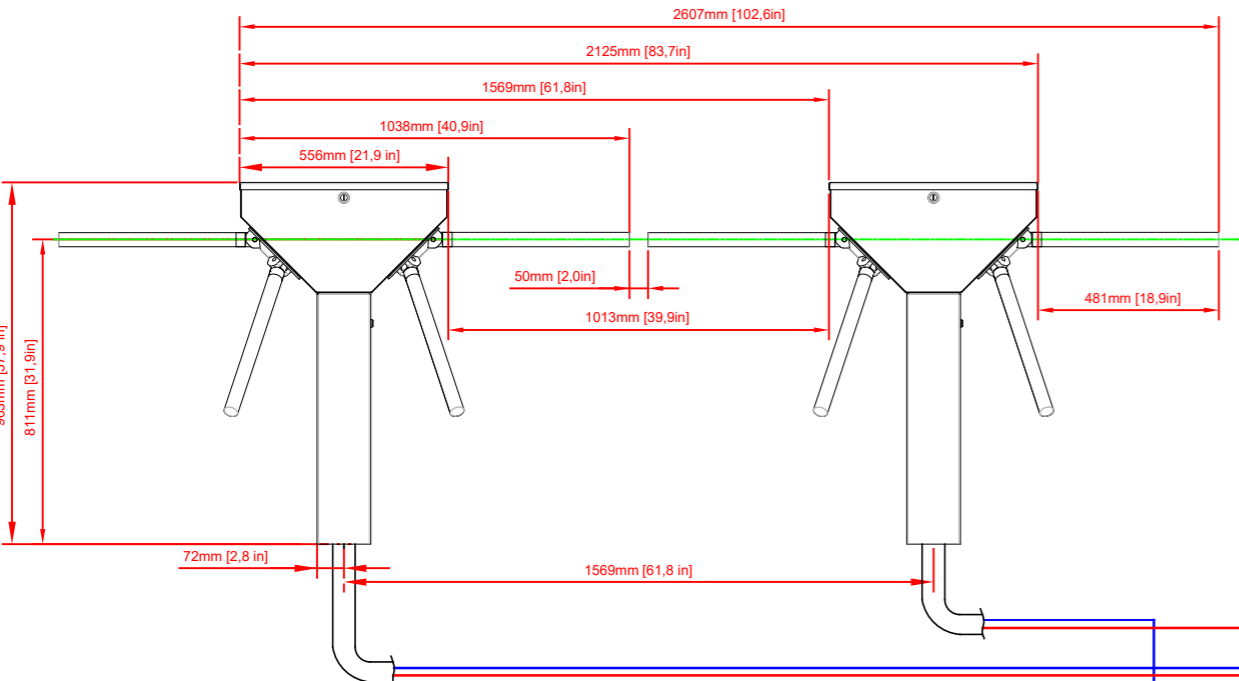

READER CONTROLLER/
LESERSTEUEREINHEIT/
CONTROLEUR POUR LELECTEUR/
СЧИТЫВАЮЩЕГО УСТРОЙСТВА/
STEROWNIK CZYTNIKOW
/CONTROLLER DI LETTORE/
CONTROLADOR DE LECTOR

Note
1. Controllers, readers, adaptors, wires, protective pipes are not components of the device.

Bemerkung:
1. Steuereinheiten, Leser, Netzteile, Leitungen, Peschelrohre sind keine Bestandteile der Anlage.

ATTENTION!
1. LECTEURS, CONTROLEURS, PUISSANCE ELECTRIQUE, CABLES, TUYAUX FLEXIBLES, NE SONT PAS COMPOSANTS DU DISPOSITIF.

Примечание:
1. Контроллеры, считывающие устройства, питатели, провода, пешели не являются составными частями оборудования.

Uwaga:
1. Sterowniki, czytniki, zasilacze, przewody, peszle nie stanowią części składowych urządzenia.

Attenzione:
1. Controlleri, lettori, alimentatore, cavi, tubetti non fanno parte delle parti integrate del dispositivo.

Atención:
1. Drivers, lectores, alimentadores, cables, tubos no son parte de componentes del dispositivo.

All Rights Reserved - GASTOP PRODUCTION LTD

GASTOP PRODUCTION LTD
Krakowska 229, 32-080 Zabierzow
EUROPEAN UNION, POLAND
tel.: +48(12) 661 53 70
fax: +48(12) 661 53 72
e-mail: gastop@gastop.com.pl
www.gastopgroup.com

DATE/DATUM/DATA/
DATA/FECHA
06.03.2026

NAME/NAME/APELLATION/
НАЗВАНИЕ/NAZWA/NOME/NOMBRE

**STI2-BR2AL
INSTALLATION A**

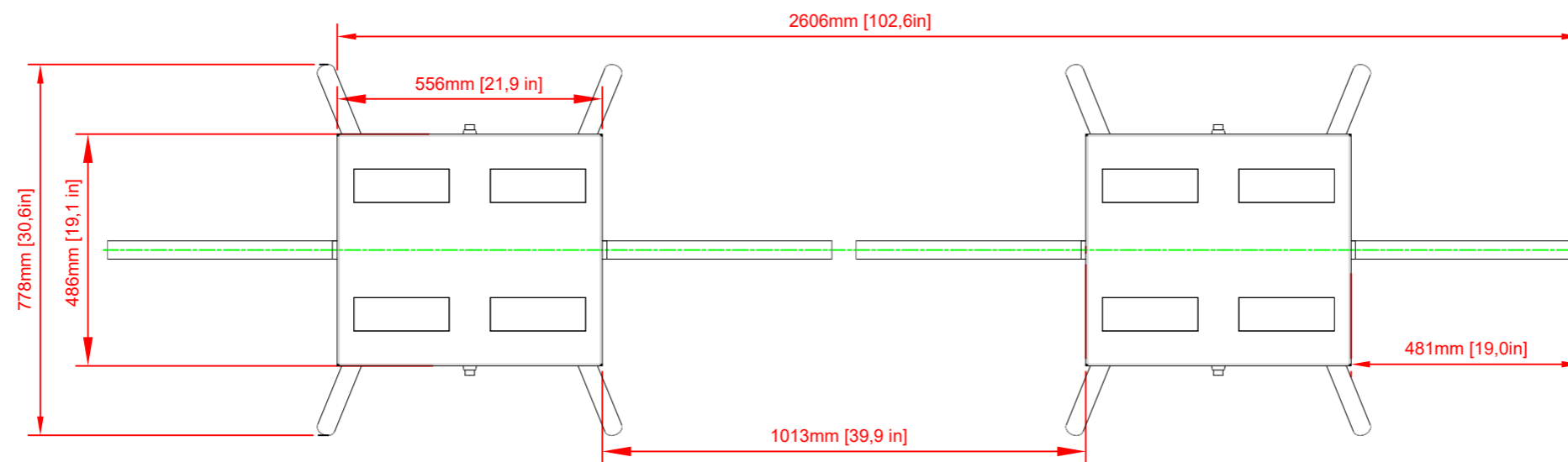
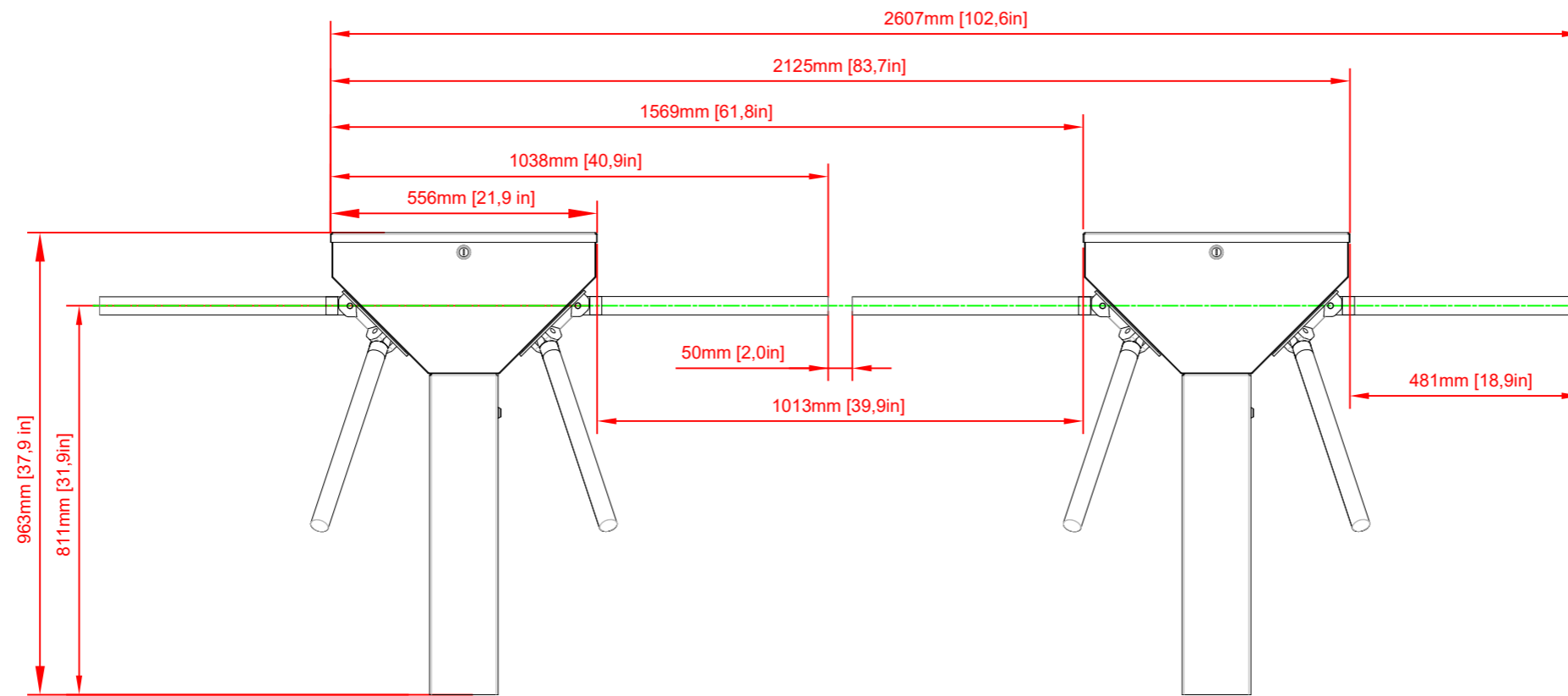

GASTOP PRODUCTION LTD

Krakowska 229, 32-080 Zabierzow
 EUROPEAN UNION, POLAND
 tel.: +48(12) 661 53 70
 fax: +48(12) 661 53 72
 e-mail: gastop@gastop.com.pl
 www.gastopgroup.com

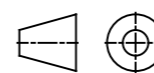

DATE/DATUM/DATA/
 DATA/FECHA

04.03.2026

NAME

STI2-BR2AL

CONFIGURATION A

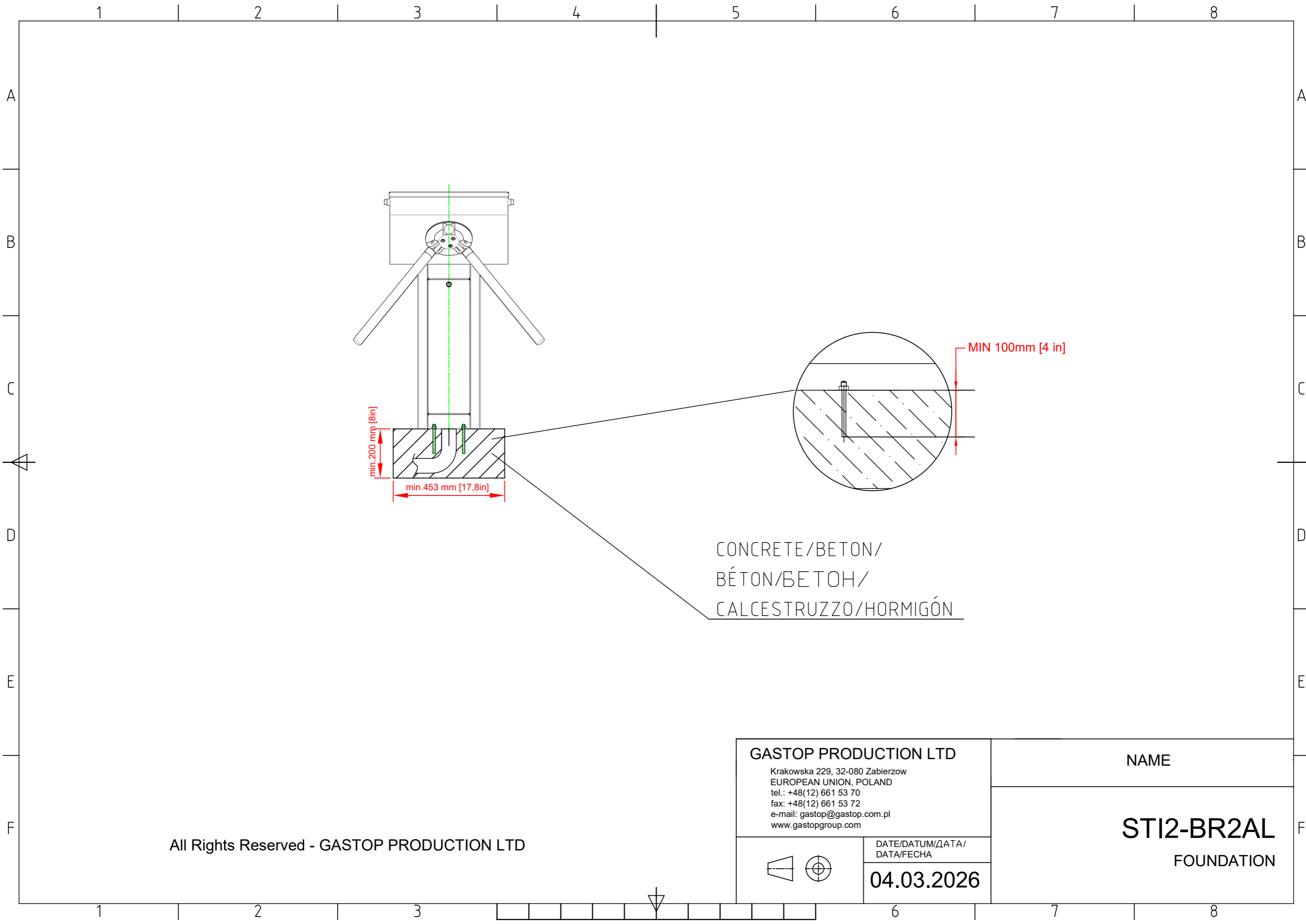

min. 200 mm [8in]
min. 453 mm [17,8in]

MIN 100mm [4 in]

CONCRETE/BETON/
BÉTON/BETON/
CALCESTRUZZO/HORMIGÓN

All Rights Reserved - GASTOP PRODUCTION LTD

GASTOP PRODUCTION LTD	
Krakowska 229, 32-080 Zabierzow EUROPEAN UNION, POLAND tel.: +48(12) 661 53 70 fax: +48(12) 661 53 72 e-mail: gastop@gastop.com.pl www.gastopgroup.com	
	DATE/DATUM/DATA/ DATA/FECHA
	04.03.2026

NAME
STI2-BR2AL
FOUNDATION

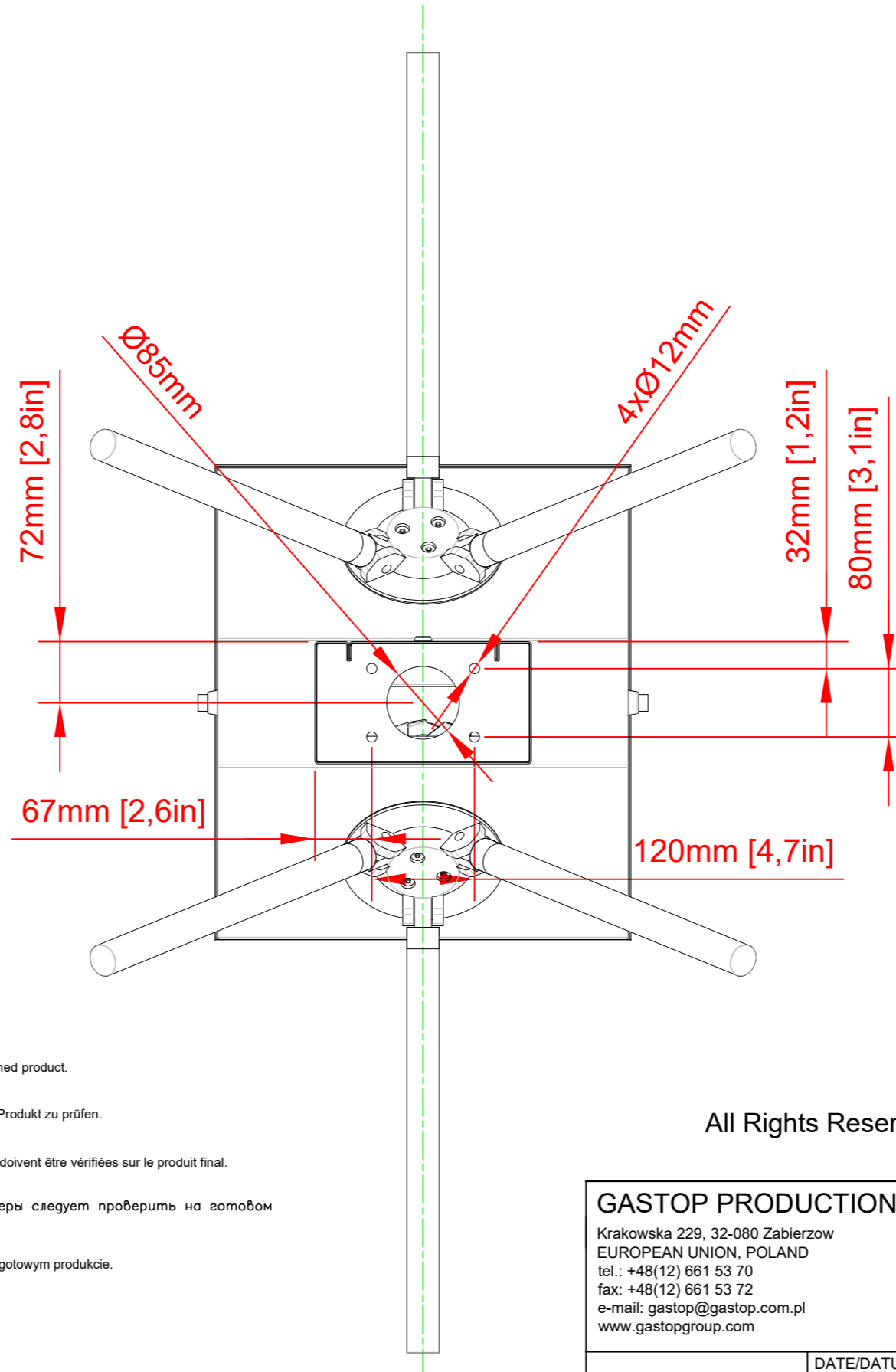

Note:

1. Drawing for initial planning where the screws holes should be. Dimensions need to be checked on a finished product.

Bemerkung:

Zeichnung zur Vorbestimmung der Anordnung von Schraubenlöchern. Die Abmessungen sind am fertigen Produkt zu prüfen.

ATTENTION:

1. Le schémat pour estimation préliminaire d'emplacement des ouvertures pour les vices.. Les dimensions doivent être vérifiées sur le produit final.

Примечание:

1. Чертеж для предварительной оценки размещения отверстий под болты. Размеры следует проверить на готовом изделии.

Uwaga:

1. Rysunek do wstępnego oszacowania rozmieszczenia otworów pod śruby. Wymiary należy sprawdzić na gotowym produkcie.

Attenzione:

1. Il disegno per la valutazione principale del collocamento dei buchi per le vite.

Le misure bisogna controllare su un prodotto pronto.

Atención:

1. El dibujo para calculación principal de distribución de aberturas por tornillos. Los tamaños hay que controlar sobre el producto acabado.

All Rights Reserved - GASTOP PRODUCTION LTD

GASTOP PRODUCTION LTD Krakowska 229, 32-080 Zabierzow EUROPEAN UNION, POLAND tel.: +48(12) 661 53 70 fax: +48(12) 661 53 72 e-mail: gastop@gastop.com.pl www.gastopgroup.com		NAME/NAME/APELLATION/ НАЗВАНИЕ/NAZWA/NOME/NOMBRE
		STI2-BR2AL FOUNDATION A
DATE/DATUM/ДАТА/ DATA/FECHA 04.03.2026		

1 2 3 4 5 6 7 8

A

A

LEFT DIRECTION/LINKE RICHTUNG/GAUCHE
/ЛЕВОЕ направление /KIERUNEK
LEWY/DIREZIONESINISTRA/DIRECCIÓN IZQUIERDA

RIGHT DIRECTION/RECHTE RICHTUNG/DROIT/
ПРАВОЕ НАПРАВЛЕНИЕ/KIERUNEK PRAWY/
DIREZIONE DESTRA/DIRECCIÓN DERECHA

B

B

C

C

D

D

E

E

F

F

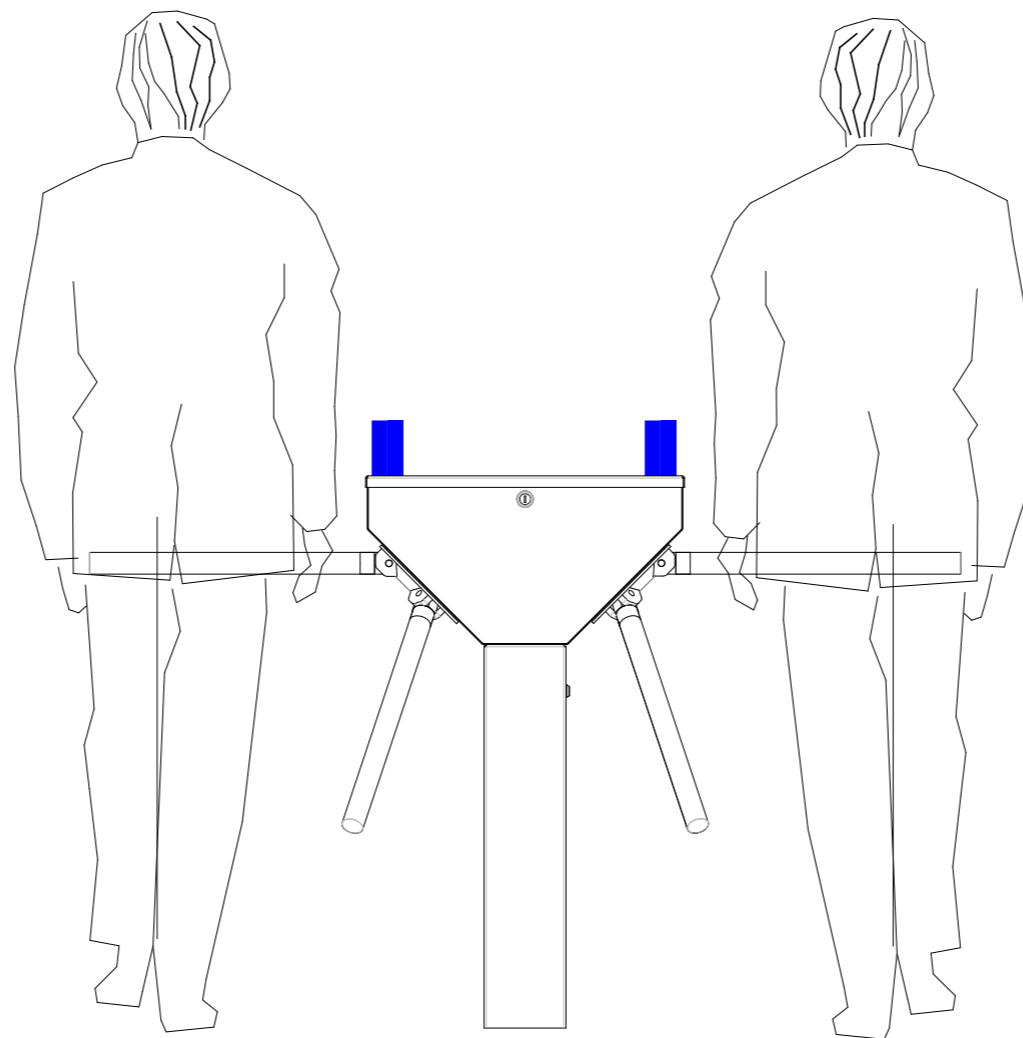

All Rights Reserved - GASTOP PRODUCTION LTD

GASTOP PRODUCTION LTD

Krakowska 229, 32-080 Zabierzow
EUROPEAN UNION, POLAND
tel.: +48(12) 661 53 70
fax: +48(12) 661 53 72
e-mail: gastop@gastop.com.pl
www.gastopgroup.com

NAME

STI2-BR2AL

INFORMATION

DATE/DATUM/DATA/
DATA/FECHA

04.03.2026

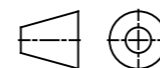

1 2 3 4 5 6 7 8

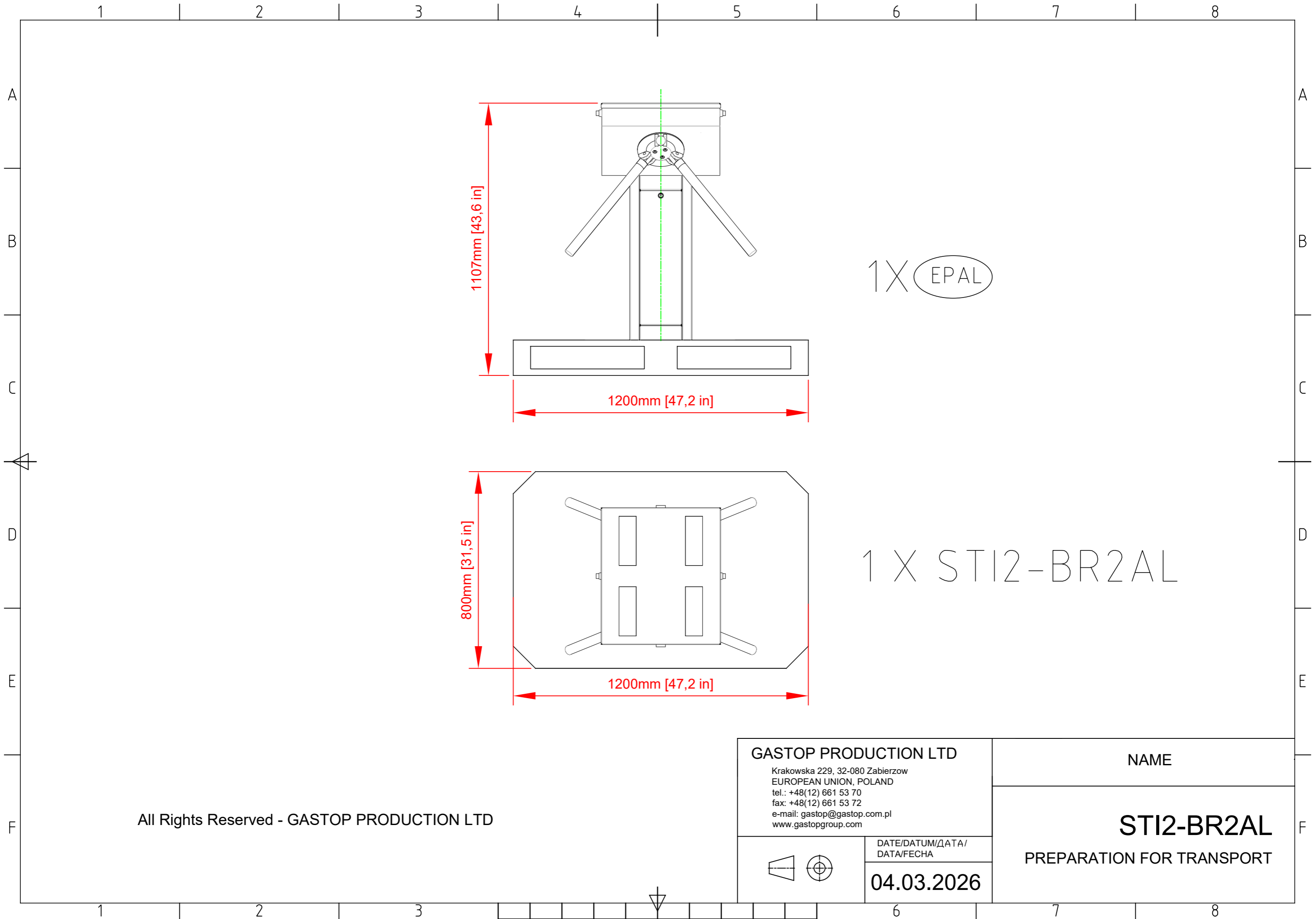

1X EPAL

1 X STI2-BR2AL

All Rights Reserved - GASTOP PRODUCTION LTD

GASTOP PRODUCTION LTD Krakowska 229, 32-080 Zabierzow EUROPEAN UNION, POLAND tel.: +48(12) 661 53 70 fax: +48(12) 661 53 72 e-mail: gastop@gastop.com.pl www.gastopgroup.com	
	DATE/DATUM/DATA/ DATA/FECHA
	04.03.2026

NAME
STI2-BR2AL
PREPARATION FOR TRANSPORT