

# STI-ZA2AL

Technical drawings

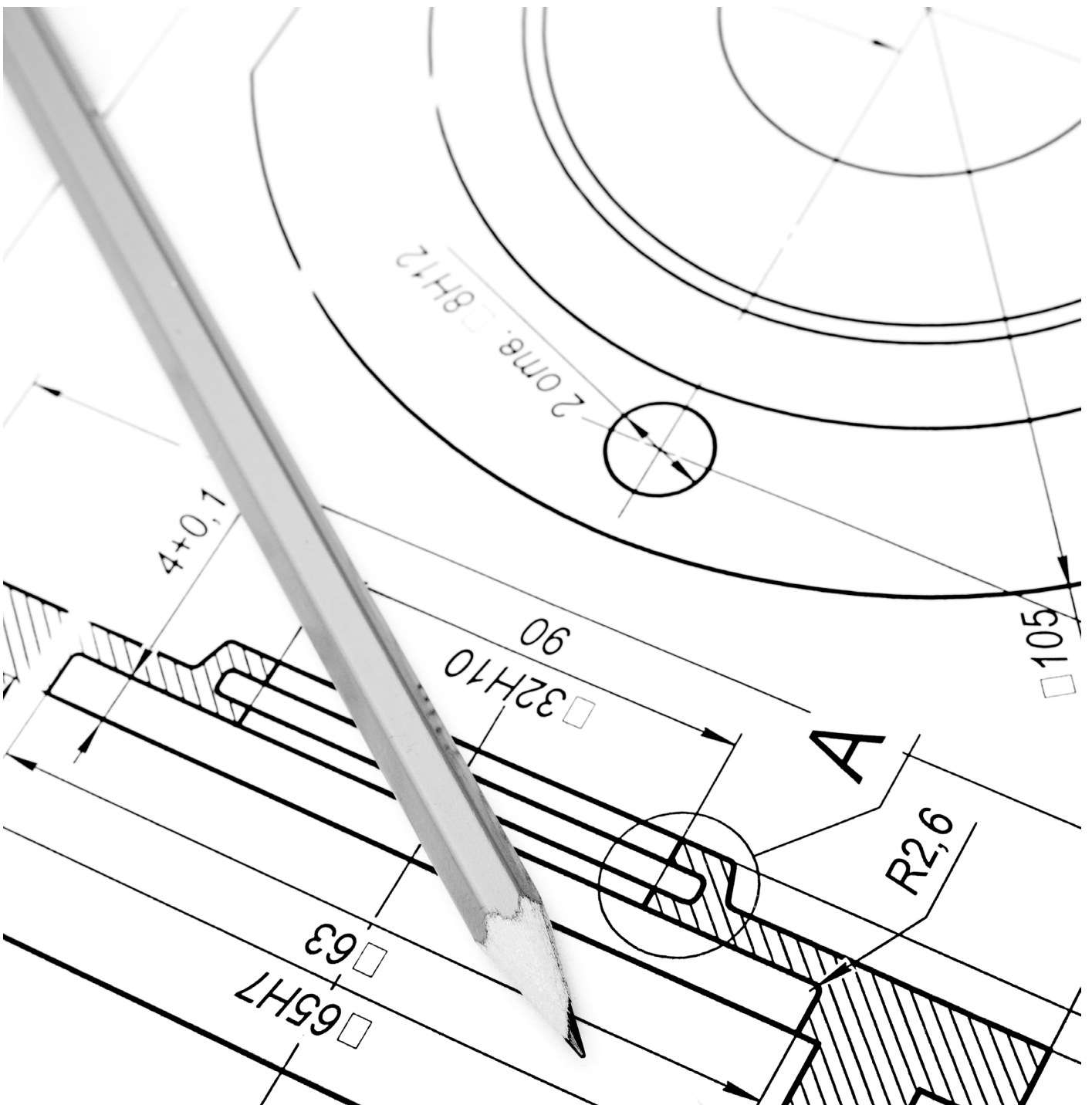

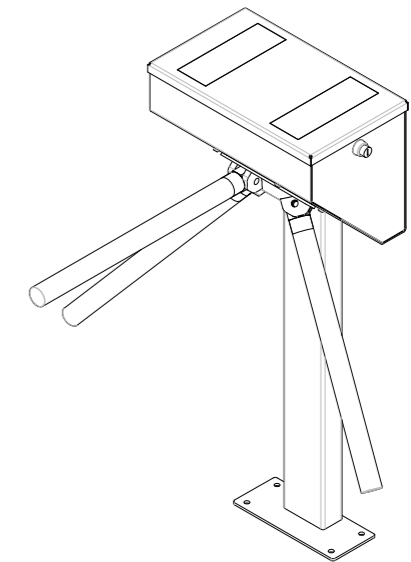
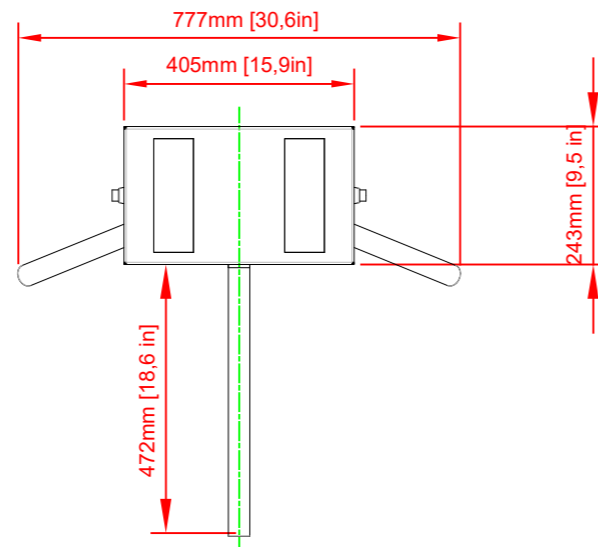
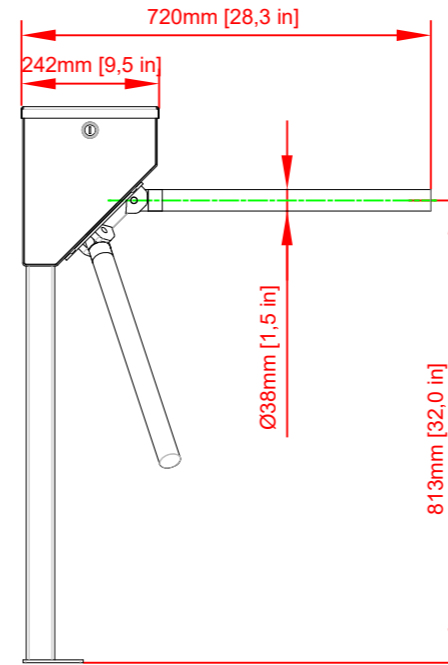
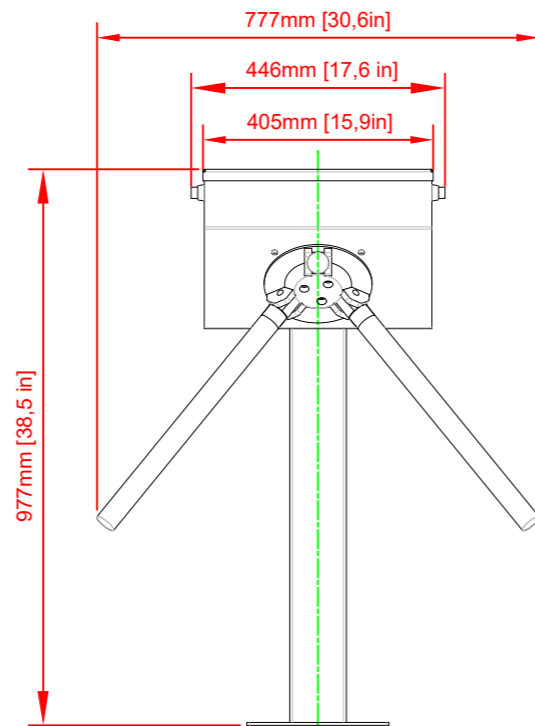

All Rights Reserved - GASTOP PRODUCTION LTD

<b>GASTOP PRODUCTION LTD</b> Krakowska 229, 32-080 Zabierzow EUROPEAN UNION, POLAND tel.: +48(12) 661 53 70 fax: +48(12) 661 53 72 e-mail: gastop@gastop.com.pl www.gastopgroup.com	NAME
	<b>STIS-ZA2AL</b> V.3.0 CONFIGURATION
	DATE/DATUM/DATA/ DATA/FECHA <b>16.05.2025</b>

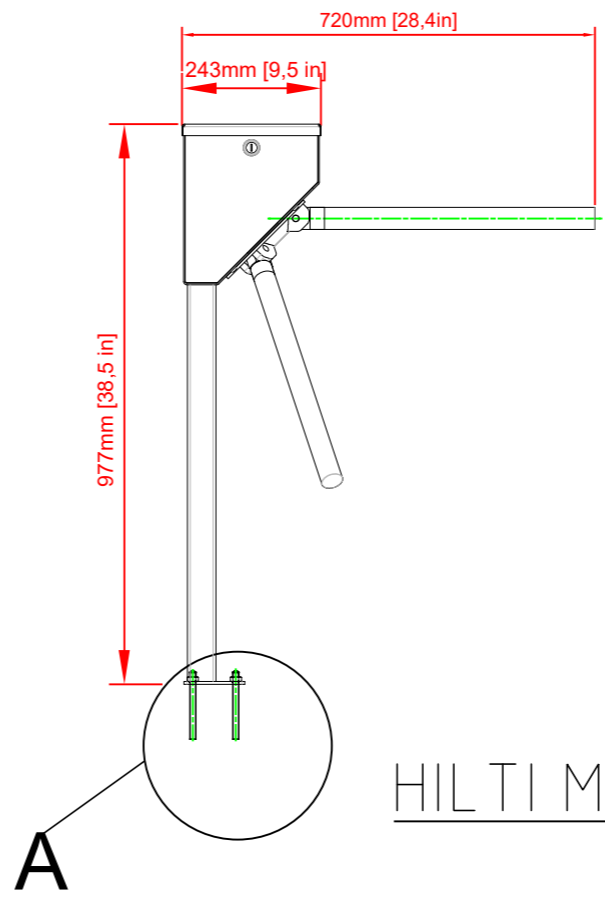
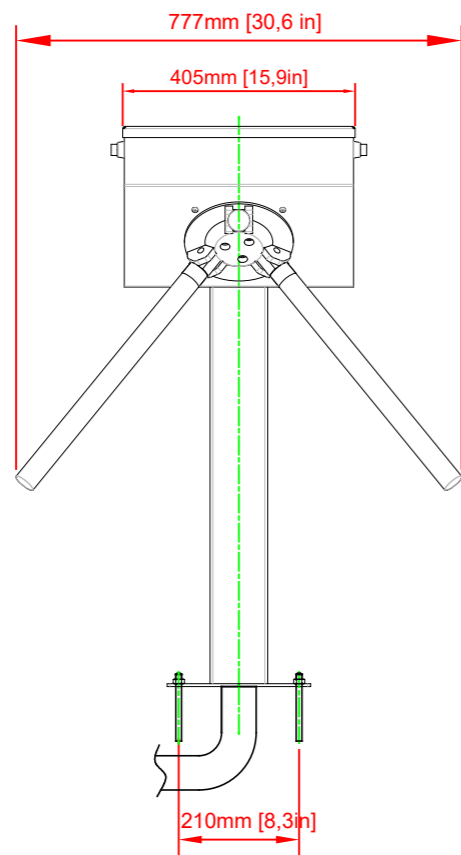

DETAIL//DÉTAIL/ДЕТАЛИ/  
SZCZEGÓŁ /DETTAGLIO/DETALLE

**A**

HILTI M 10

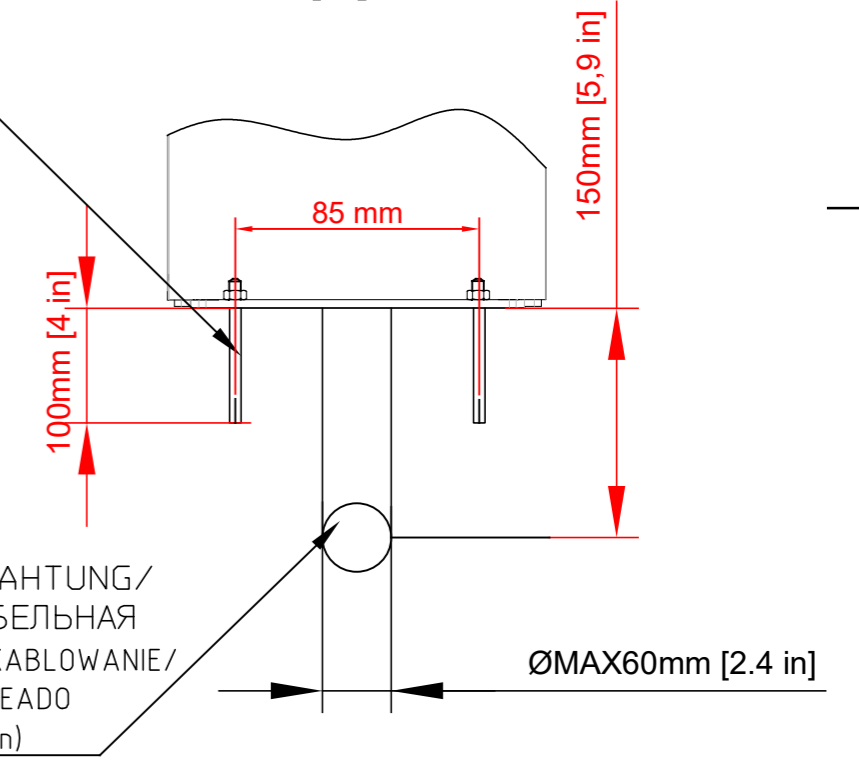

WIRING/VERDRAHTUNG/  
CABLAGE / КАБЕЛЬНАЯ  
ПРОВОДКА/OKABLOWANIE/  
CABLAGGIO/CABLEADO  
(MAX Ø60mm/2,4 in)

- Note**  
1. Controllers, readers, adaptors, wires, protective pipes are not components of the device.
- Bemerkung:**  
1. Steuereinheiten, Leser, Netzteile, Leitungen, Peschelrohre sind keine Bestandteile der Anlage.
- ATTENTION!**  
1. LECTEURS, CONTROLEURS, PUISSANCE ELECTRIQUE, CABLES, TUYAUX FLEXIBLES, NE SONT PAS COMPOSANTS DU DISPOSITIF.
- Примечание:**  
1. Контроллеры, считывающие устройства, питатели, провода, пешели не являются составными частями оборудования.
- Uwaga:**  
1. Sterowniki, czytniki, zasilacze, przewody, peszle nie stanowią części składowych urządzenia.
- Attenzione:**  
1. Controlleri, lettori, alimentatore, cavi, tubetti non fanno parte delle parti integrate del dispositivo.
- Atención:**  
1. Drivers, lectores, alimentadores, cables, tubos no son parte de componentes del despositivo.

All Rights Reserved - GASTOP PRODUCTION LTD

<b>GASTOP PRODUCTION LTD</b> Krakowska 229, 32-080 Zabierzow EUROPEAN UNION, POLAND tel.: +48(12) 661 53 70 fax: +48(12) 661 53 72 e-mail: gastop@gastop.com.pl www.gastopgroup.com	NAME
	<b>STIS-ZA2AL</b> V.3.0 INSTALATION
	DATE/DATUM/DATA/ DATA/FECHA <b>16.05.2025</b>

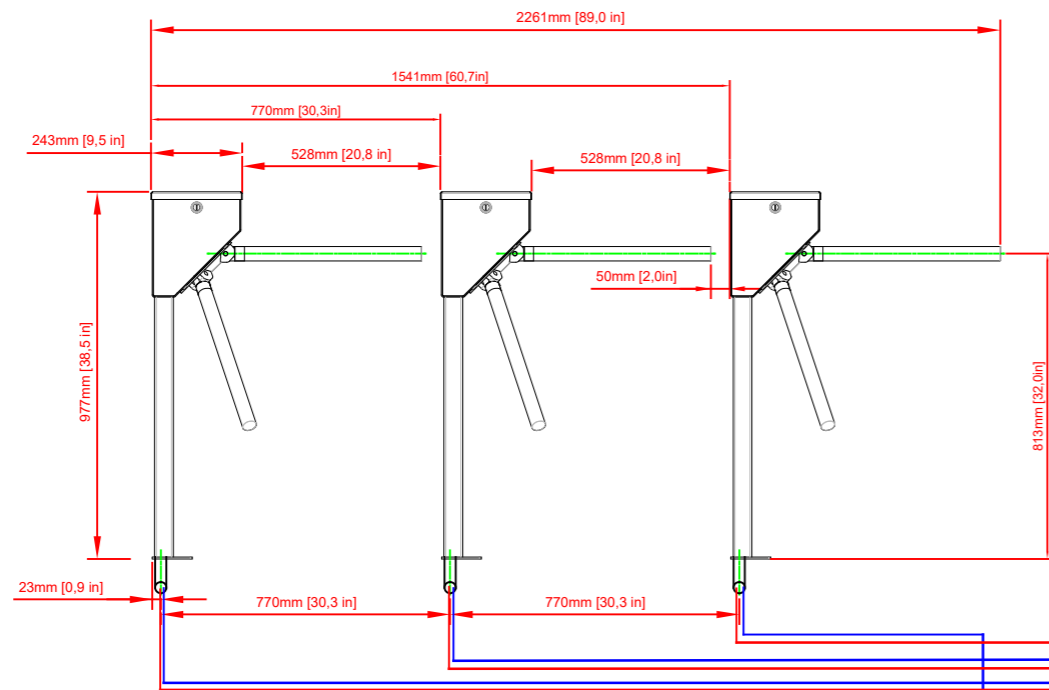

WIRING/VERDRÄHTUNG/CABLAGE/КАБЕЛЬНАЯ ПРОВОДКА/OKABLOWANIE/CABLAGGIO/CABLEADO			
TYPE/MODELL/ТИП/ TYP/TIPO/	FTP	YDY or /oder/ou/или/ lub/oppure/OMY	
QUANTITY/MENGE/ QUANTITE//СКОЛЬКО/ ILOŚĆ/NUMERO/	6	6	
SIZE/GRÖSSE / GABARIT / PAZMER/ROZMIAR/ TAGLIA/TAMAÑO	8x0.5 [mm <sup>2</sup> ]	L < 50[m]	3x1.5 [mm <sup>2</sup> ]
	8x0.0008 [in <sup>2</sup> ]	L < 50[yd]	3x0.003 [mm <sup>2</sup> ]
		L > 50[m]	3x2.5 [mm <sup>2</sup> ]
		L > 50[yd]	3x0.004 [mm <sup>2</sup> ]

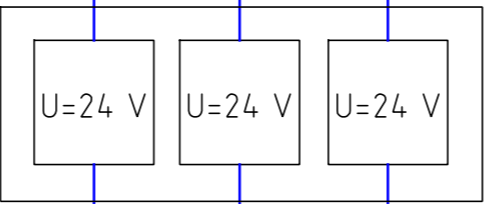

READER CONTROLLER/  
LESERSTEUEREINHEIT/  
CONTROLEUR POUR LELECTEUR/  
СЧИТЫВАЮЩЕГО УСТРОЙСТВА/  
STEROWNIK CZYTNIKOW  
/CONTROLLER DI LETTORE/  
CONTROLADOR DE LECTOR

**Note**  
1. Controllers, readers, adaptors, wires, protective pipes are not components of the device.

**Bemerkung:**  
1. Steuereinheiten, Leser, Netzteile, Leitungen, Peschelrohre sind keine Bestandteile der Anlage.

**ATTENTION!**  
1. LECTEURS, CONTROLEURS, PUISSANCE ELECTRIQUE, CABLES, TUYAUX FLEXIBLES, NE SONT PAS COMPOSANTS DU DISPOSITIF.

**Примечание:**  
1. Контроллеры, считывающие устройства, питатели, провода, пешели не являются составными частями оборудования.

**Uwaga:**  
1. Sterowniki, czytniki, zasilacze, przewody, peszle nie stanowią części składowych urządzenia.

**Attenzione:**  
1. Controlleri, lettori, alimentatore, cavi, tubetti non fanno parte delle parti integrate del dispositivo.

**Atención:**  
1. Drivers, lectores, alimentadores, cables, tubos no son parte de componentes del despositivo.

All Rights Reserved - GASTOP PRODUCTION LTD

**GASTOP PRODUCTION LTD**  
Krakowska 229, 32-080 Zabierzow  
EUROPEAN UNION, POLAND  
tel.: +48(12) 661 53 70  
fax: +48(12) 661 53 72  
e-mail: gastop@gastop.com.pl  
www.gastopgroup.com

DATE/DATUM/ДАТА/  
DATA/FECHA  
**16.05.2025**

NAME/NAME/APELLATION/  
НАЗВАНИЕ/NAZWA/NOME/NOMBRE

**STIS-ZA2AL**  
V.3.0  
INSTALATION A

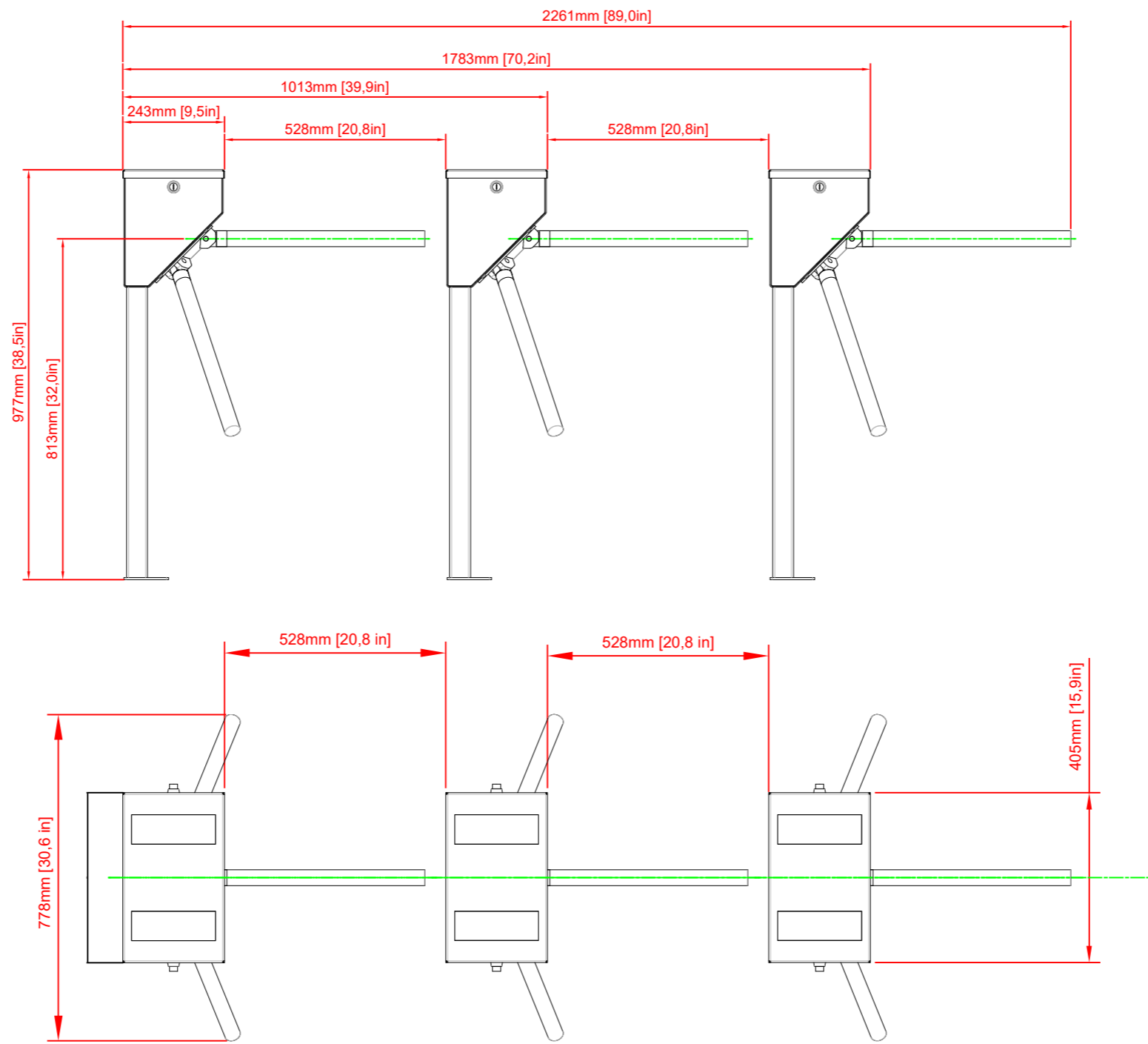

**GASTOP PRODUCTION LTD**  
 Krakowska 229, 32-080 Zabierzow  
 EUROPEAN UNION, POLAND  
 tel.: +48(12) 661 53 70  
 fax: +48(12) 661 53 72  
 e-mail: gastop@gastop.com.pl  
 www.gastopgroup.com

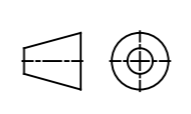

DATE/DATUM/DATA/  
 DATA/FECHA  
**16.05.2025**

NAME
<b>STIS-ZA2AL</b>
V.3.0
CONFIGURATION A

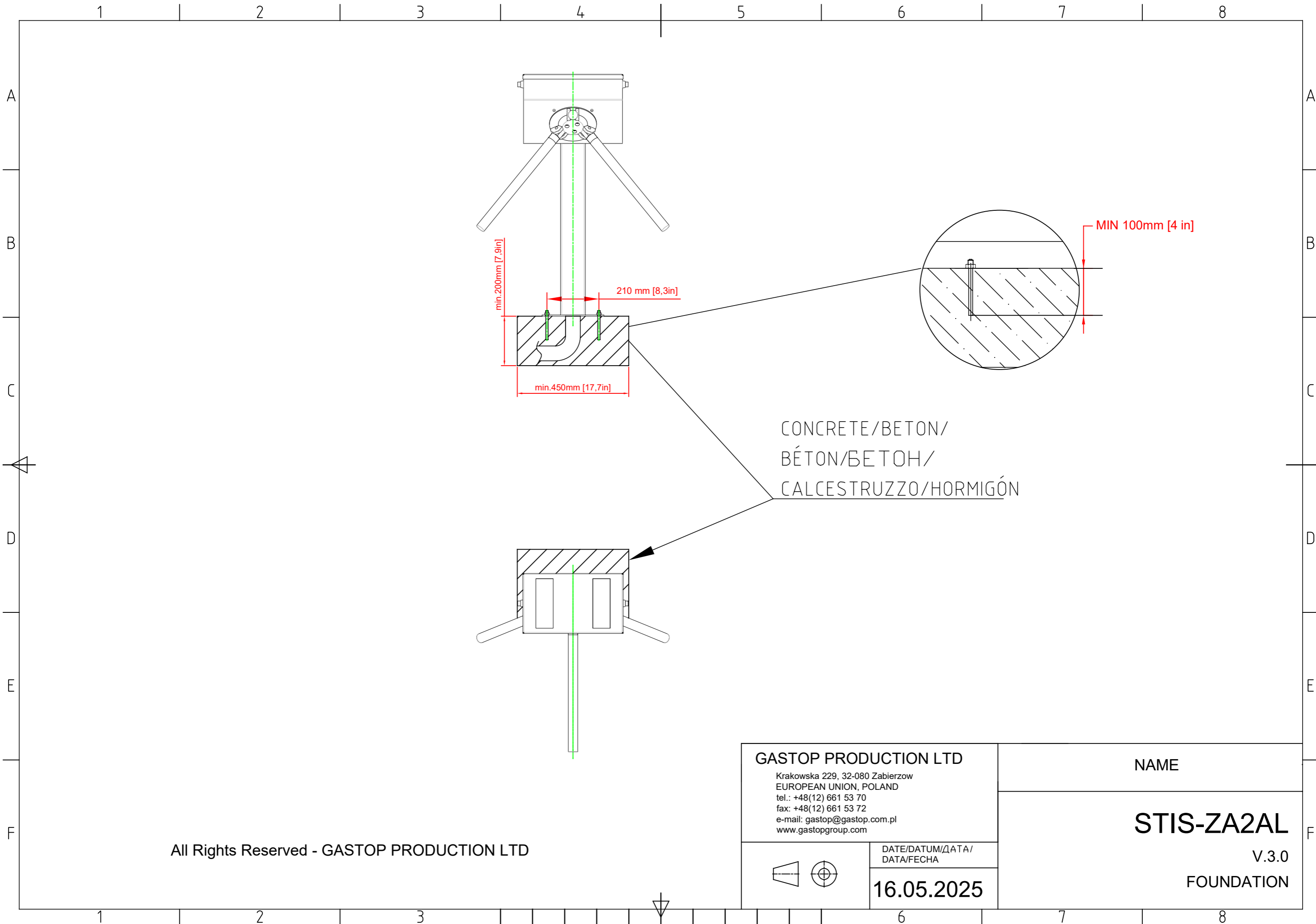

<b>GASTOP PRODUCTION LTD</b> Krakowska 229, 32-080 Zabierzow EUROPEAN UNION, POLAND tel.: +48(12) 661 53 70 fax: +48(12) 661 53 72 e-mail: gastop@gastop.com.pl www.gastopgroup.com		NAME	
		<b>STIS-ZA2AL</b>	
DATE/DATUM/DATA/ DATA/FECHA		V.3.0	
<b>16.05.2025</b>		FOUNDATION	

All Rights Reserved - GASTOP PRODUCTION LTD

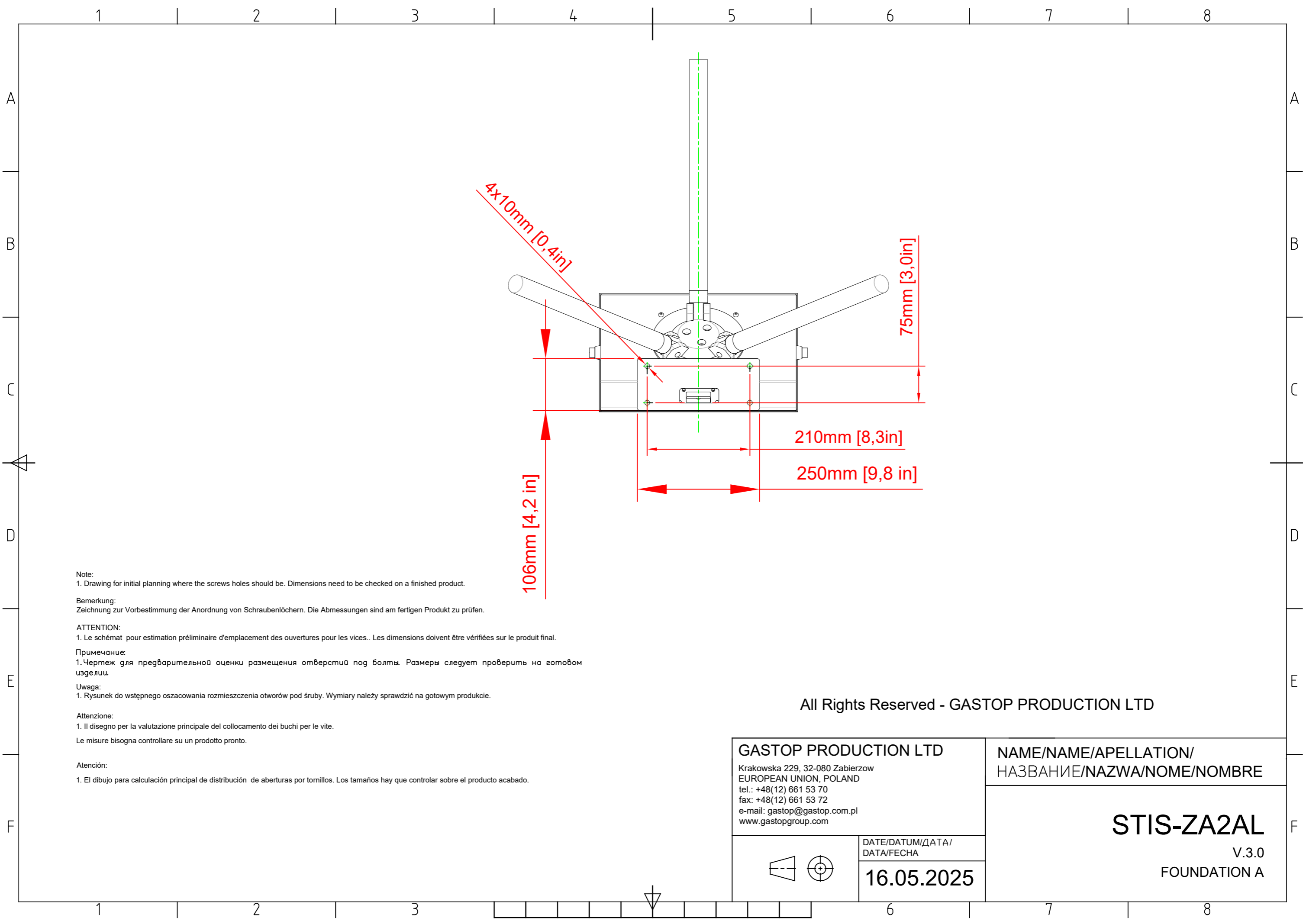

**Note:**  
 1. Drawing for initial planning where the screws holes should be. Dimensions need to be checked on a finished product.

**Bemerkung:**  
 Zeichnung zur Vorbestimmung der Anordnung von Schraubenlöchern. Die Abmessungen sind am fertigen Produkt zu prüfen.

**ATTENTION:**  
 1. Le schémat pour estimation préliminaire d'emplacement des ouvertures pour les vices.. Les dimensions doivent être vérifiées sur le produit final.

**Примечание:**  
 1.Чертеж для предварительной оценки размещения отверстий под болты. Размеры следует проверить на готовом изделии.

**Uwaga:**  
 1. Rysunek do wstępnego oszacowania rozmieszczenia otworów pod śruby. Wymiary należy sprawdzić na gotowym produkcie.

**Attenzione:**  
 1. Il disegno per la valutazione principale del collocamento dei buchi per le vite.  
 Le misure bisogna controllare su un prodotto pronto.

**Atención:**  
 1. El dibujo para calculación principal de distribución de aberturas por tornillos. Los tamaños hay que controlar sobre el producto acabado.

All Rights Reserved - GASTOP PRODUCTION LTD

<b>GASTOP PRODUCTION LTD</b> Krakowska 229, 32-080 Zabierzow EUROPEAN UNION, POLAND tel.: +48(12) 661 53 70 fax: +48(12) 661 53 72 e-mail: gastop@gastop.com.pl www.gastopgroup.com	NAME/NAME/APELLATION/ НАЗВАНИЕ/NAZWA/NOME/NOMBRE
	<b>STIS-ZA2AL</b> V.3.0 FOUNDATION A
	DATE/DATUM/DATA/ DATA/FECHA <b>16.05.2025</b>

1 2 3 4 5 6 7 8

A

A

LEFT DIRECTION/LINKE RICHTUNG/GAUCHE  
/ЛЕВОЕ направление /KIERUNEK  
LEWY/DIREZIONE SINISTRA/DIRECCIÓN IZQUIERDA

RIGHT DIRECTION/RECHTE RICHTUNG/DROIT/  
ПРАВОЕ НАПРАВЛЕНИЕ/KIERUNEK PRAWY/  
DIREZIONE DESTRA/DIRECCIÓN DERECHA

B

B

C

C

D

D

E

E

F

F

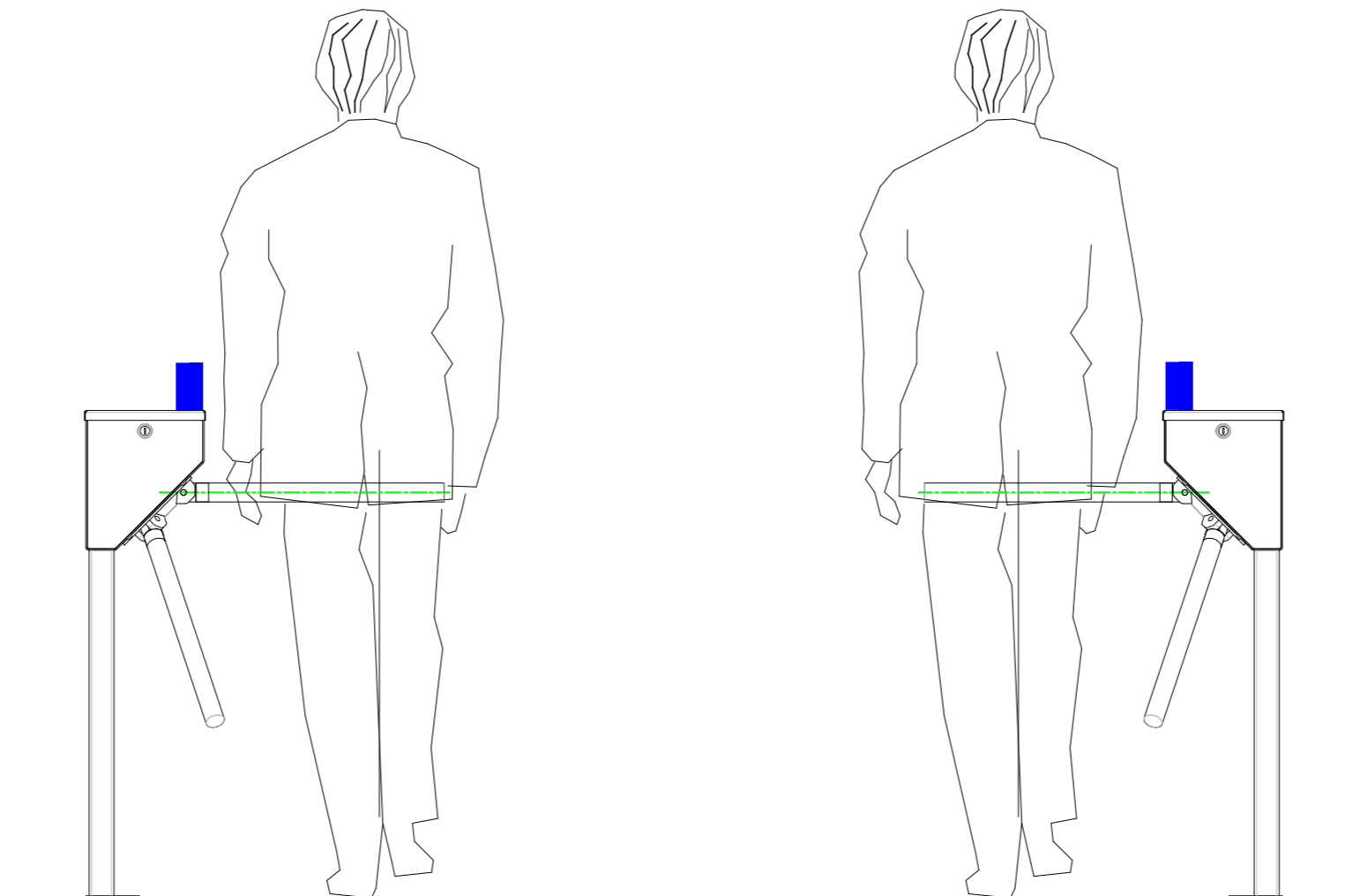

All Rights Reserved - GASTOP PRODUCTION LTD

**GASTOP PRODUCTION LTD**

Krakowska 229, 32-080 Zabierzow  
EUROPEAN UNION, POLAND  
tel.: +48(12) 661 53 70  
fax: +48(12) 661 53 72  
e-mail: gastop@gastop.com.pl  
www.gastopgroup.com

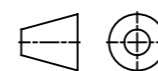

DATE/DATUM/DATA/  
DATA/FECHA

16.05.2025

NAME

**STIS-ZA2AL**

V.3.0

INFORMATION

1 2 3 4 5 6 7 8

1 2 3 4 5 6 7 8

A

A

B

B

C

C

D

D

E

E

F

F

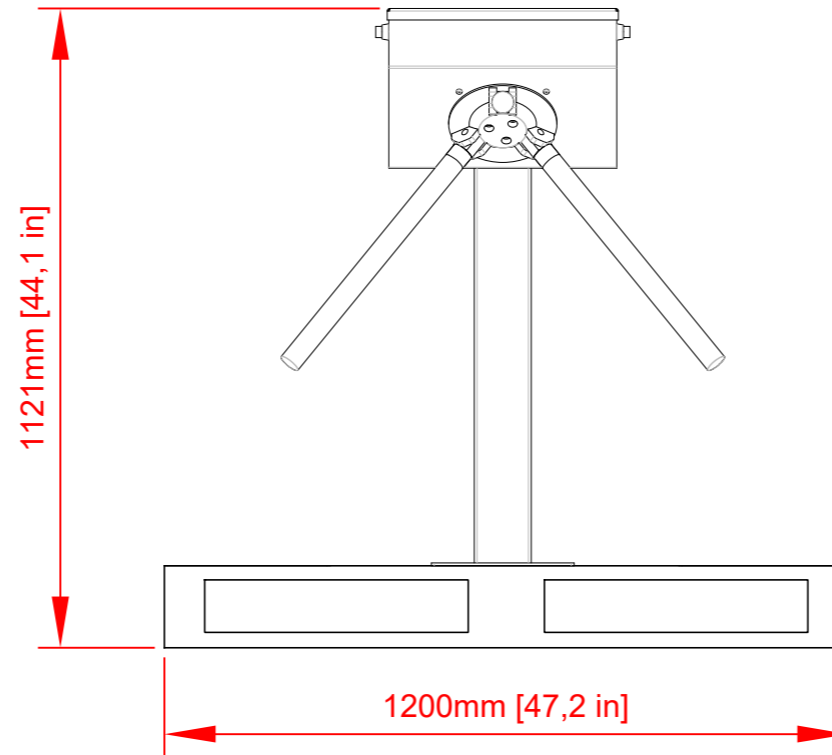

1 X EPAL

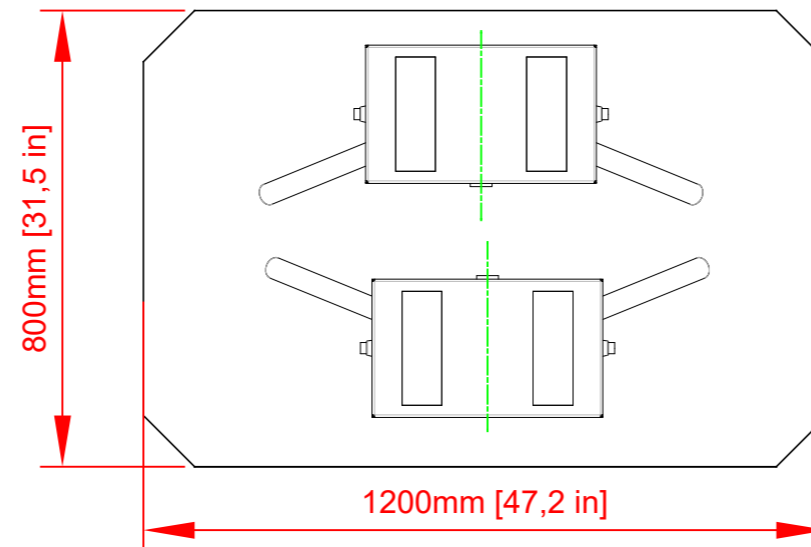

2 X STIS-ZA2AL

All Rights Reserved - GASTOP PRODUCTION LTD

<b>GASTOP PRODUCTION LTD</b> Krakowska 229, 32-080 Zabierzow EUROPEAN UNION, POLAND tel.: +48(12) 661 53 70 fax: +48(12) 661 53 72 e-mail: gastop@gastop.com.pl www.gastopgroup.com	NAME
	<b>STIS-ZA2AL</b> V.3.0 PREPARATION FOR TRANSPORT
	DATE/DATUM/DATA/ DATA/FECHA <b>16.05.2025</b>

1 2 3 4 5 6 7 8