

# N2S-ZA2AL

Technical drawings

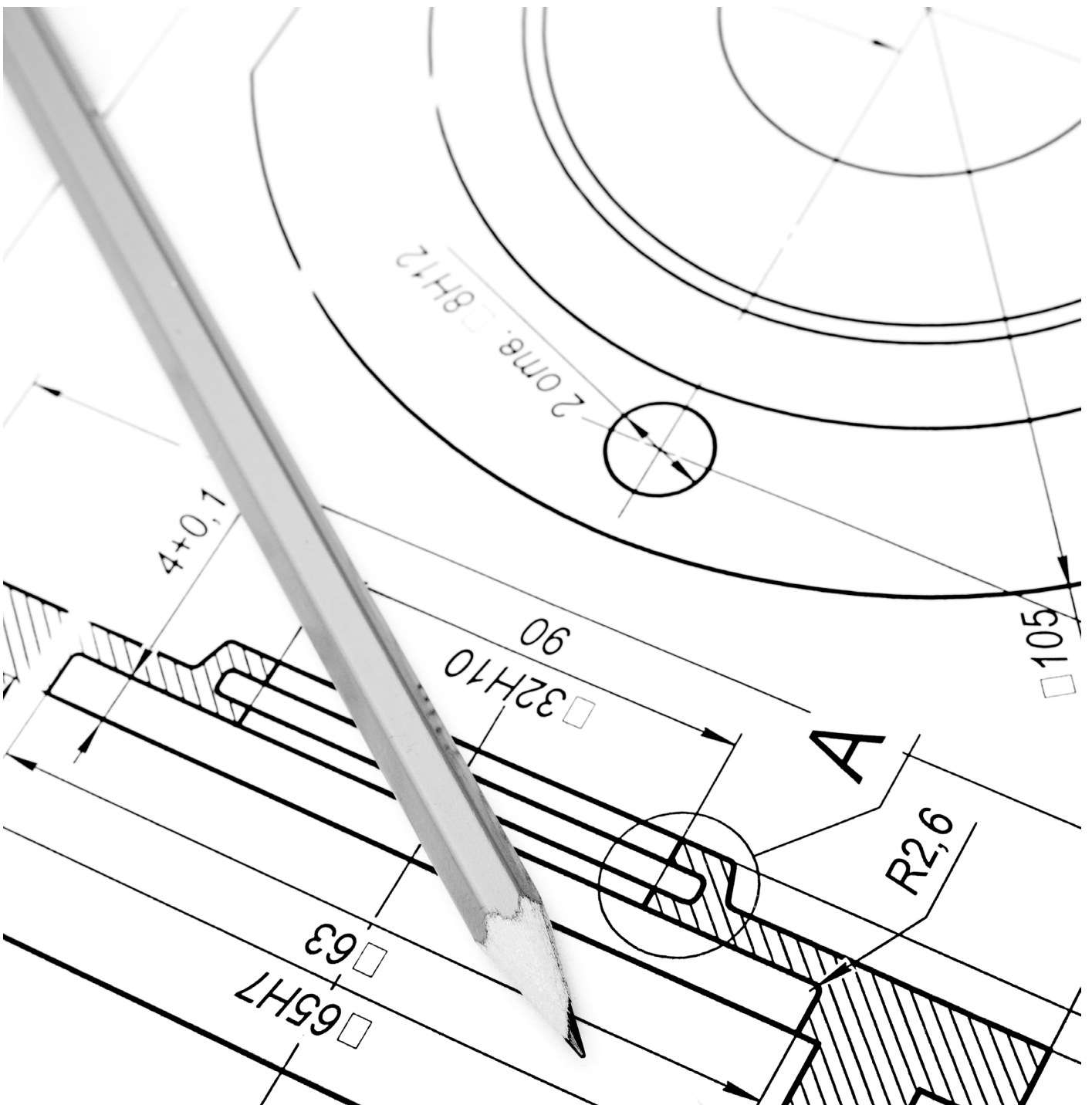

1

2

3

4

5

6

7

8

A

B

C

D

E

F

A

B

C

D

E

F

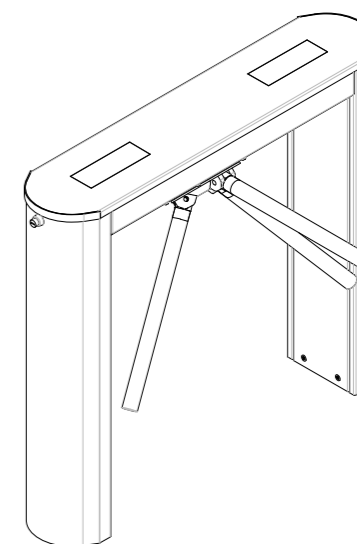
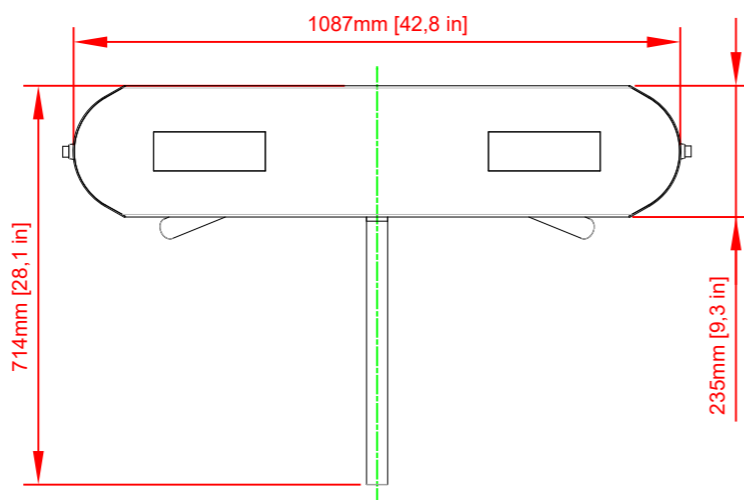
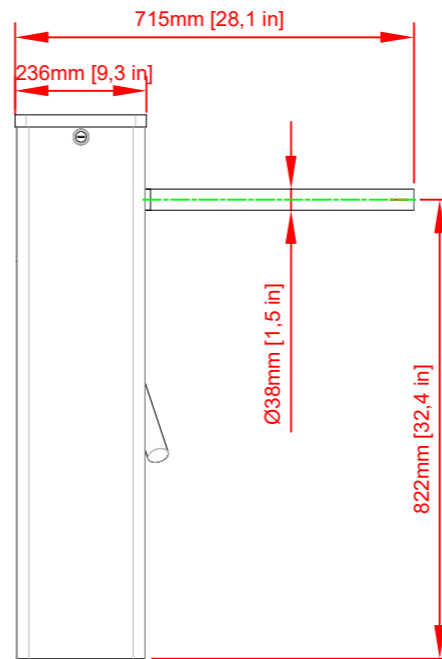
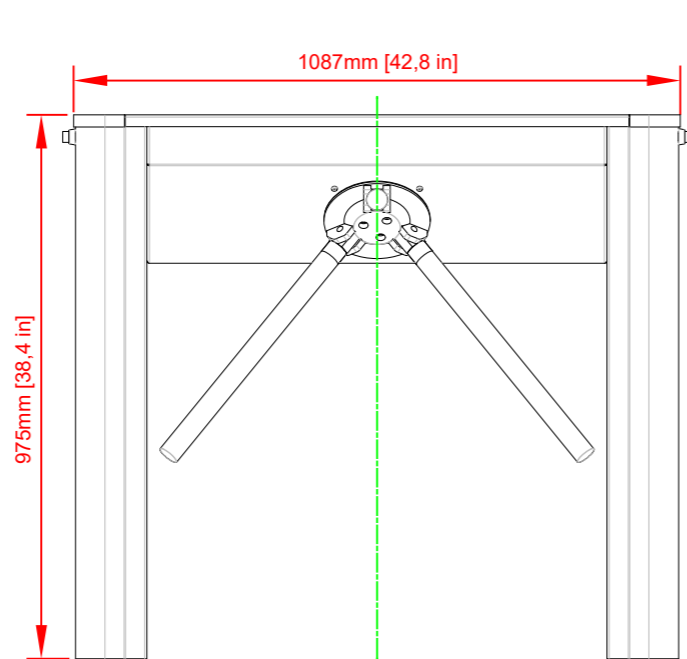

All Rights Reserved - GASTOP PRODUCTION LTD

**GASTOP PRODUCTION LTD**

Krakowska 229, 32-080 Zabierzow  
 EUROPEAN UNION, POLAND  
 tel.: +48(12) 661 53 70  
 fax: +48(12) 661 53 72  
 e-mail: gastop@gastop.com.pl  
 www.gastopgroup.com

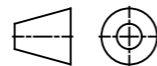

DATE/DATUM/ДАТА/  
DATA/FECHA

**12.05.2025**

NAME

**N2S-ZA2AL**

V.3.0

CONFIGURATION

1

2

3

6

7

8

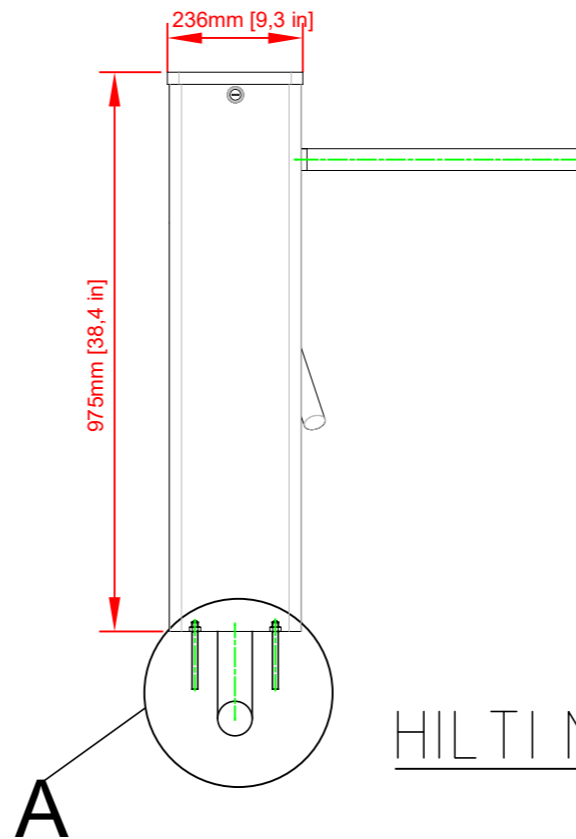
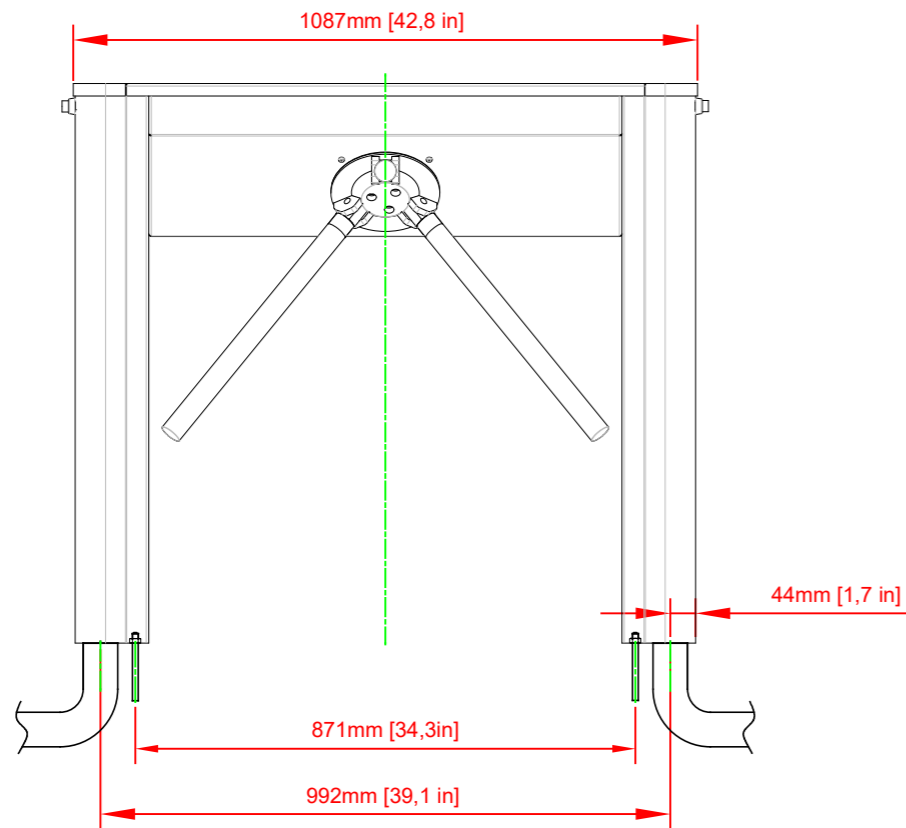

DETAIL//DÉTAIL/ДЕТАЛИ/  
SZCZEGÓŁ /DETTAGLIO/DETALLE

**A**

HILTI M 10

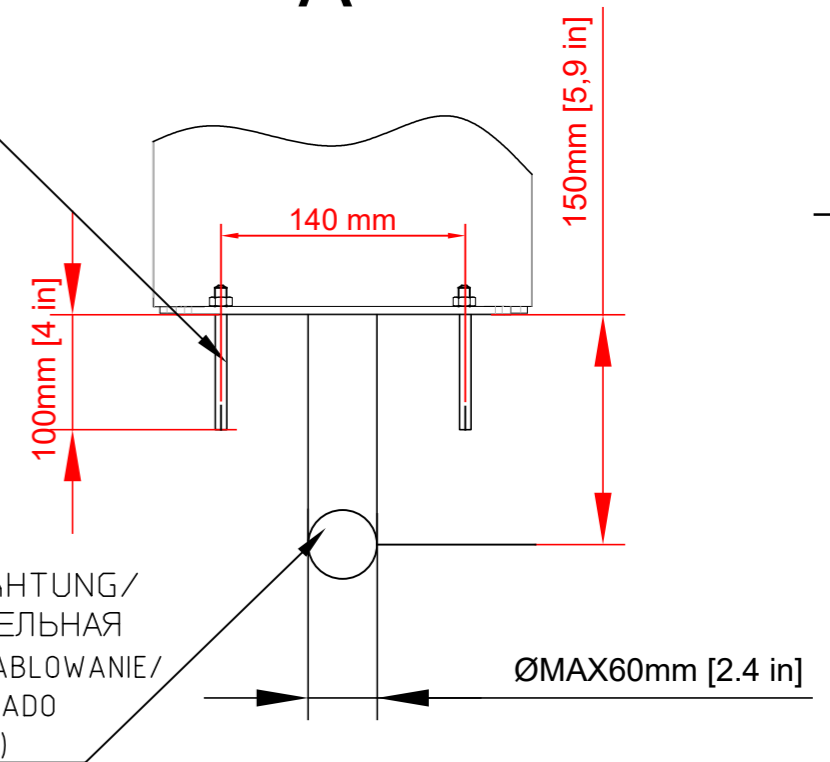

WIRING/VERDRAHTUNG/  
CABLAGE / КАБЕЛЬНАЯ  
ПРОВОДКА/OKABLOWANIE/  
CABLAGGIO/CABLEADO  
(MAX Ø60mm/2,4in)

**Note**

1. Controllers, readers, adaptors, wires, protective pipes are not components of the device.

**Bemerkung:**

1. Steuereinheiten, Leser, Netzteile, Leitungen, Peschelrohre sind keine Bestandteile der Anlage.

**ATTENTION!**

1. LECTEURS, CONTROLEURS, PUISSANCE ELECTRIQUE, CABLES, TUYAUX FLEXIBLES, NE SONT PAS COMPOSANTS DU DISPOSITIF.

**Примечание:**

1. Контроллеры, считывающие устройства, питатели, провода, пешели не являются составными частями оборудования.

**Uwaga:**

1. Sterowniki, czytniki, zasilacze, przewody, peszle nie stanowią części składowych urządzenia.

**Attenzione:**

1. Controlleri, lettori, alimentatore, cavi, tubetti non fanno parte delle parti integrate del dispositivo.

**Atención:**

1. Drivers, lectores, alimentadores, cables, tubos no son parte de componentes del despositivo.

All Rights Reserved - GASTOP PRODUCTION LTD

|                                                                                                                                                                                                       |                                                     |
|-------------------------------------------------------------------------------------------------------------------------------------------------------------------------------------------------------|-----------------------------------------------------|
| <b>GASTOP PRODUCTION LTD</b><br>Krakowska 229, 32-080 Zabierzow<br>EUROPEAN UNION, POLAND<br>tel.: +48(12) 661 53 70<br>fax: +48(12) 661 53 72<br>e-mail: gastop@gastop.com.pl<br>www.gastopgroup.com | NAME                                                |
|                                                                                                                                                                                                       | <b>N2S-ZA2AL</b><br>V.3.0<br>INSTALATION            |
|                                                                                                                                                                                                       | DATE/DATUM/DATA/<br>DATA/FECHA<br><b>12.05.2025</b> |

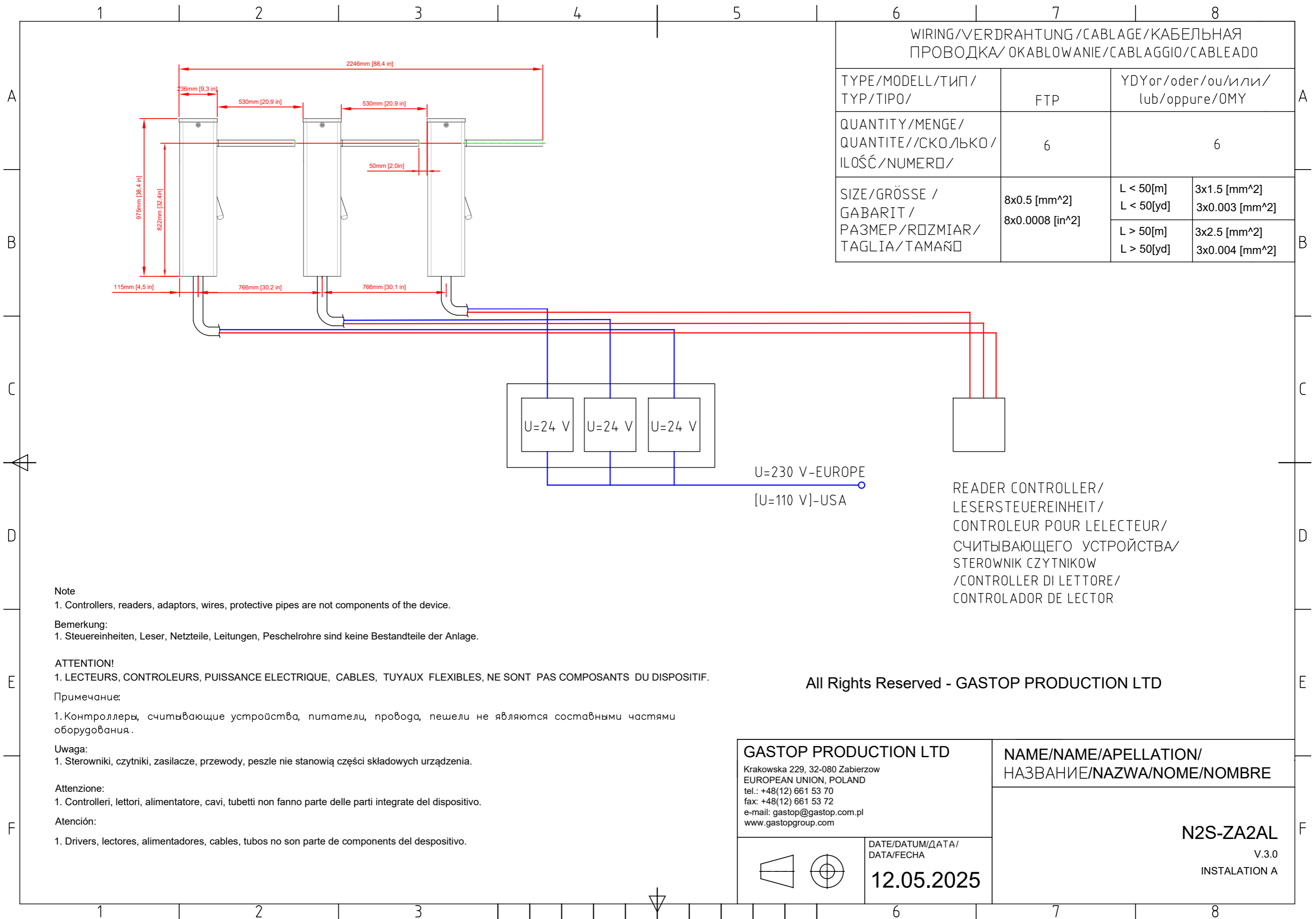

|                                                                              |                                                         |                                   |                                                        |
|------------------------------------------------------------------------------|---------------------------------------------------------|-----------------------------------|--------------------------------------------------------|
| WIRING/VERDRÄHTUNG/CABLAGE/КАБЕЛЬНАЯ ПРОВОДКА/OKABLOWANIE/CABLAGGIO/CABLEADO |                                                         |                                   |                                                        |
| TYPE/MODELL/ТИП/ TYP/TIPO/                                                   | FTP                                                     | YDYor/oder/ou/или/ lub/oppure/OMY |                                                        |
| QUANTITY/MENGE/ QUANTITE//СКОЛЬКО/ ILOŚĆ/NUMERO/                             | 6                                                       | 6                                 |                                                        |
| SIZE/GRÖSSE / GABARIT / PAZMEP/ROZMIAR/ TAGLIA/TAMAÑO                        | 8x0.5 [mm <sup>2</sup> ]<br>8x0.0008 [in <sup>2</sup> ] | L < 50[m]<br>L < 50[yd]           | 3x1.5 [mm <sup>2</sup> ]<br>3x0.003 [mm <sup>2</sup> ] |
|                                                                              |                                                         | L > 50[m]<br>L > 50[yd]           | 3x2.5 [mm <sup>2</sup> ]<br>3x0.004 [mm <sup>2</sup> ] |

**Note**  
1. Controllers, readers, adaptors, wires, protective pipes are not components of the device.

**Bemerkung:**  
1. Steuereinheiten, Leser, Netzteile, Leitungen, Peschelrohre sind keine Bestandteile der Anlage.

**ATTENTION!**  
1. LECTEURS, CONTROLEURS, PUISSANCE ELECTRIQUE, CABLES, TUYAUX FLEXIBLES, NE SONT PAS COMPOSANTS DU DISPOSITIF.

**Примечание:**  
1. Контроллеры, считывающие устройства, питатели, провода, пешели не являются составными частями оборудования.

**Uwaga:**  
1. Sterowniki, czytniki, zasilacze, przewody, peszle nie stanowią części składowych urządzenia.

**Attenzione:**  
1. Controlleri, lettori, alimentatore, cavi, tubetti non fanno parte delle parti integrate del dispositivo.

**Atención:**  
1. Drivers, lectores, alimentadores, cables, tubos no son parte de componentes del despositivo.

READER CONTROLLER/  
LESERSTEUEREINHEIT/  
CONTROLEUR POUR LELECTEUR/  
СЧИТЫВАЮЩЕГО УСТРОЙСТВА/  
STEROWNIK CZYTNIKOW  
/CONTROLLER DI LETTORE/  
CONTROLADOR DE LECTOR

All Rights Reserved - GASTOP PRODUCTION LTD

**GASTOP PRODUCTION LTD**  
Krakowska 229, 32-080 Zabierzow  
EUROPEAN UNION, POLAND  
tel.: +48(12) 661 53 70  
fax: +48(12) 661 53 72  
e-mail: gastop@gastop.com.pl  
www.gastopgroup.com

DATE/DATUM/DATA/  
DATA/FECHA  
**12.05.2025**

NAME/NAME/APELLATION/  
НАЗВАНИЕ/NAZWA/NOME/NOMBRE

**N2S-ZA2AL**  
V.3.0  
INSTALATION A

1 2 3 4 5 6 7 8

A

B

C

D

E

F

A

B

C

D

E

F

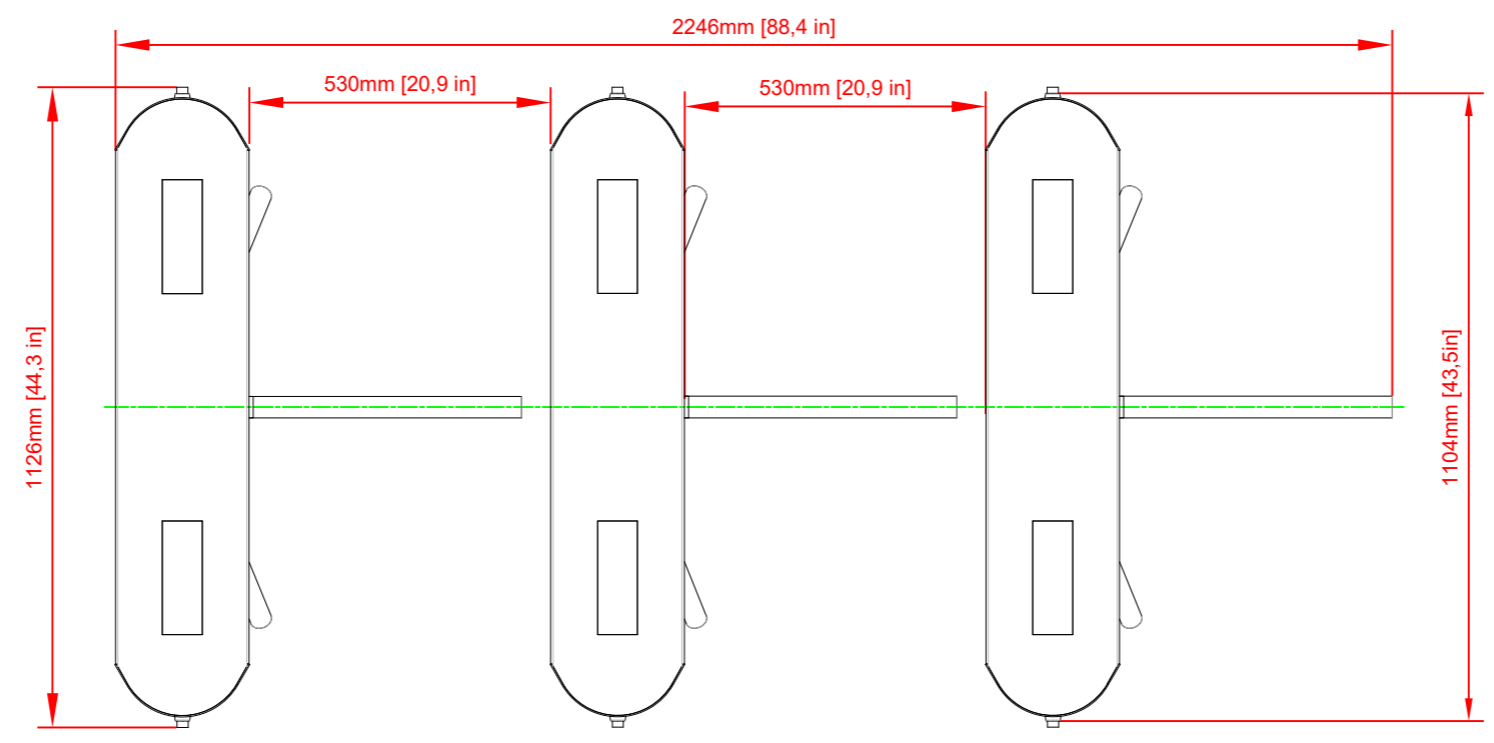
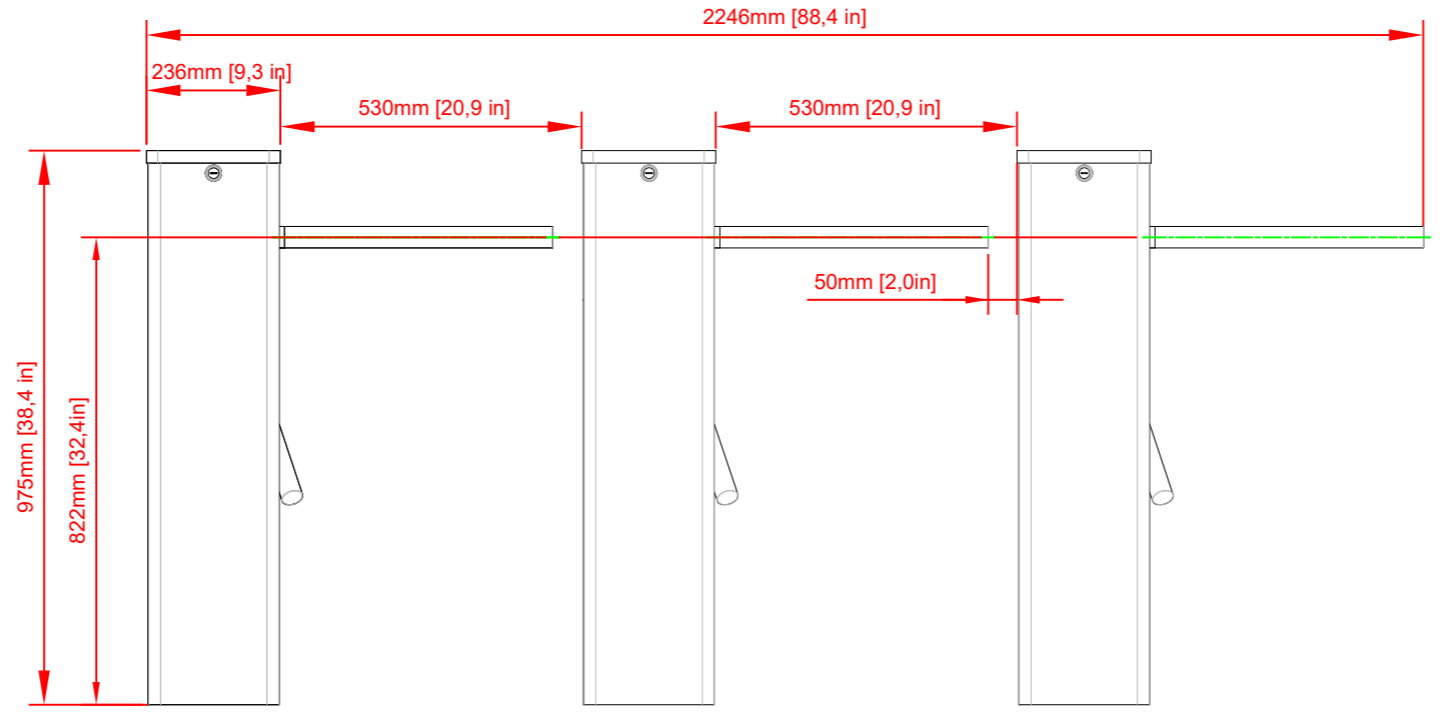

**GASTOP PRODUCTION LTD**  
 Krakowska 229, 32-080 Zabierzow  
 EUROPEAN UNION, POLAND  
 tel.: +48(12) 661 53 70  
 fax: +48(12) 661 53 72  
 e-mail: gastop@gastop.com.pl  
 www.gastopgroup.com

DATE/DATUM/DATA/  
DATA/FECHA  
**12.05.2025**

NAME

**N2S-ZA2AL**

V.3.0

CONFIGURATION A

1 2 3 4 5 6 7 8

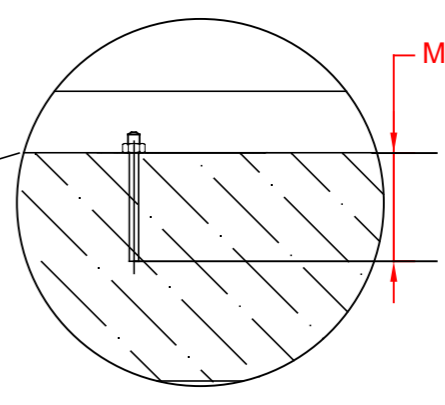
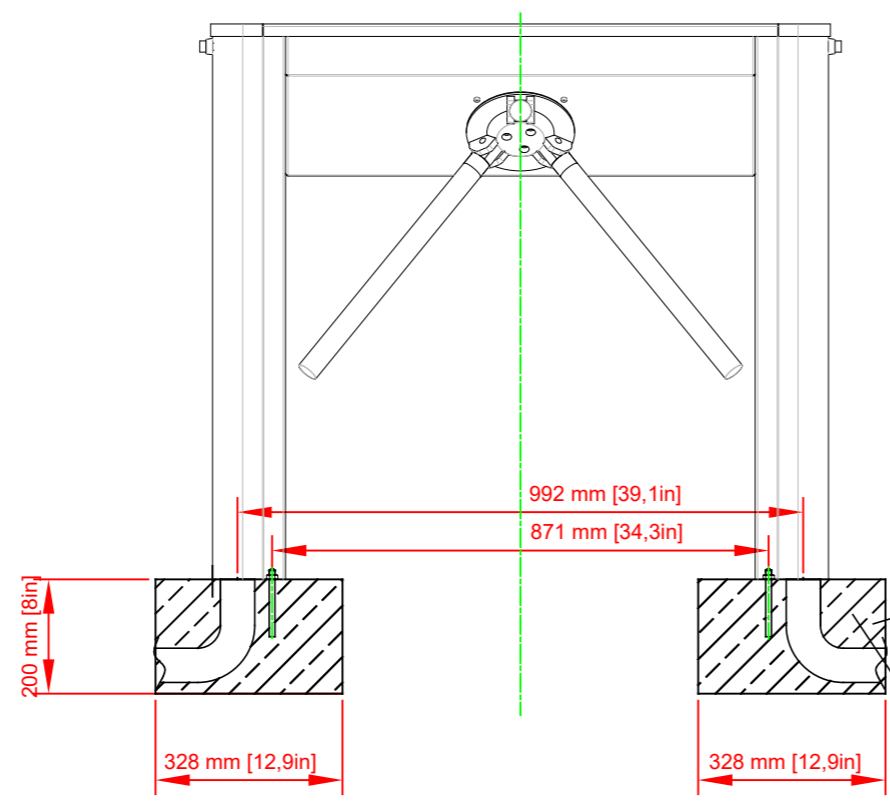
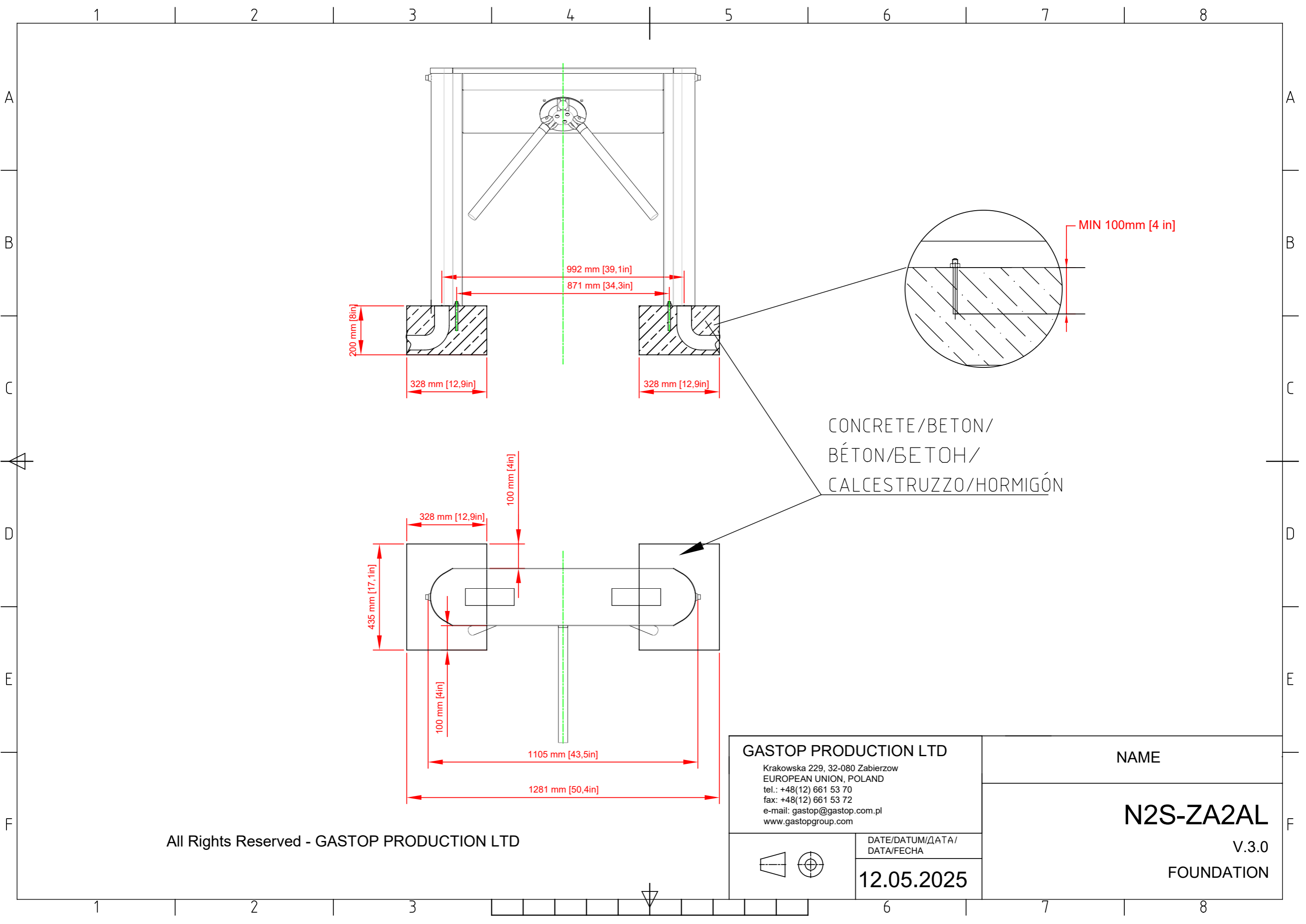

CONCRETE/BETON/  
BÉTON/BETON/  
CALCESTRUZZO/HORMIGÓN

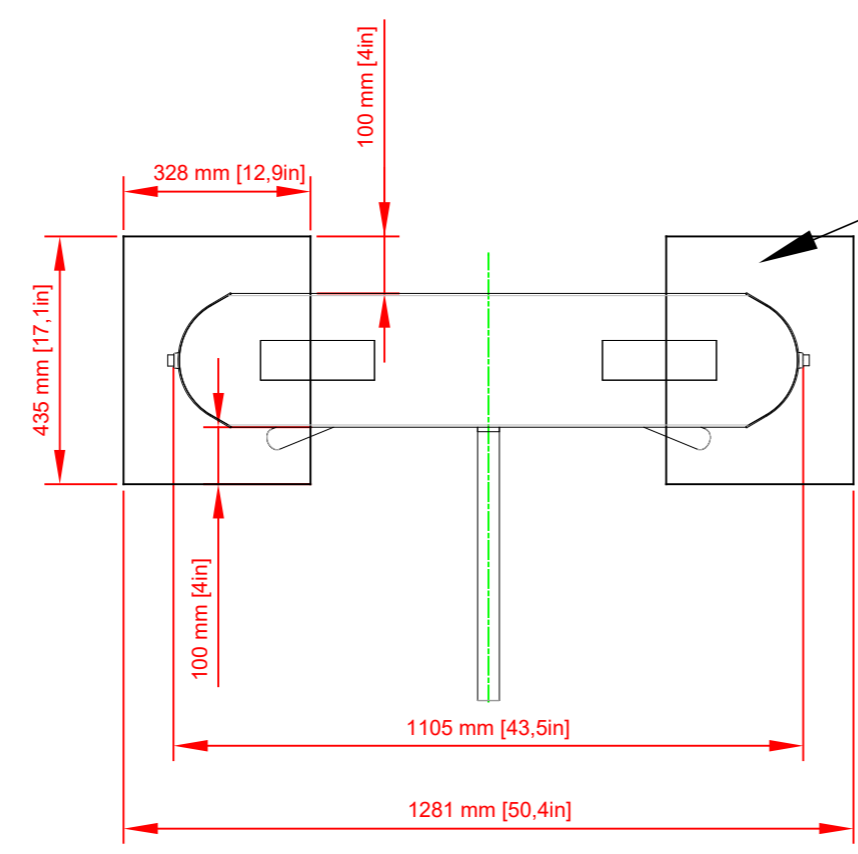

All Rights Reserved - GASTOP PRODUCTION LTD

|                                                                                                                                                                                                       |                                                     |
|-------------------------------------------------------------------------------------------------------------------------------------------------------------------------------------------------------|-----------------------------------------------------|
| <b>GASTOP PRODUCTION LTD</b><br>Krakowska 229, 32-080 Zabierzow<br>EUROPEAN UNION, POLAND<br>tel.: +48(12) 661 53 70<br>fax: +48(12) 661 53 72<br>e-mail: gastop@gastop.com.pl<br>www.gastopgroup.com |                                                     |
|                                                                                                                                                                                                       | DATE/DATUM/DATA/<br>DATA/FECHA<br><b>12.05.2025</b> |

|                  |
|------------------|
| NAME             |
| <b>N2S-ZA2AL</b> |
| V.3.0            |
| FOUNDATION       |

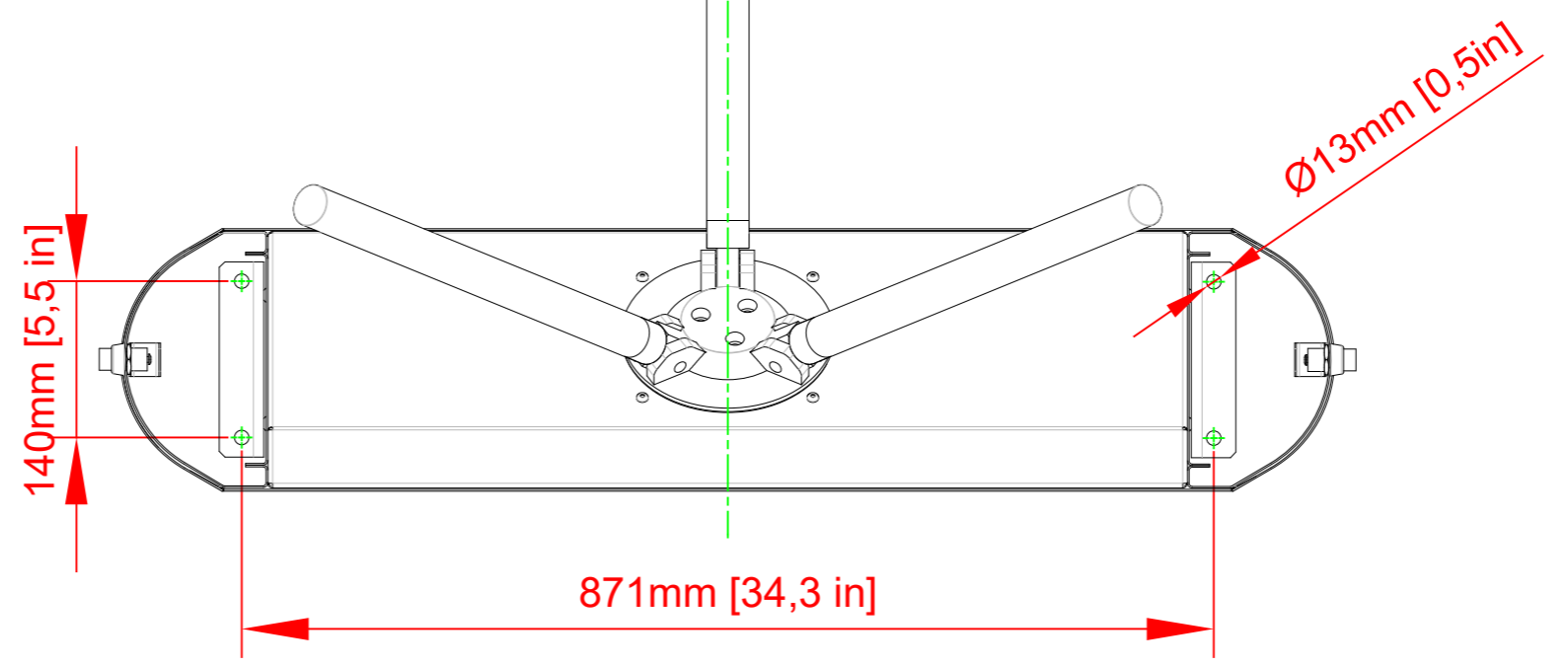
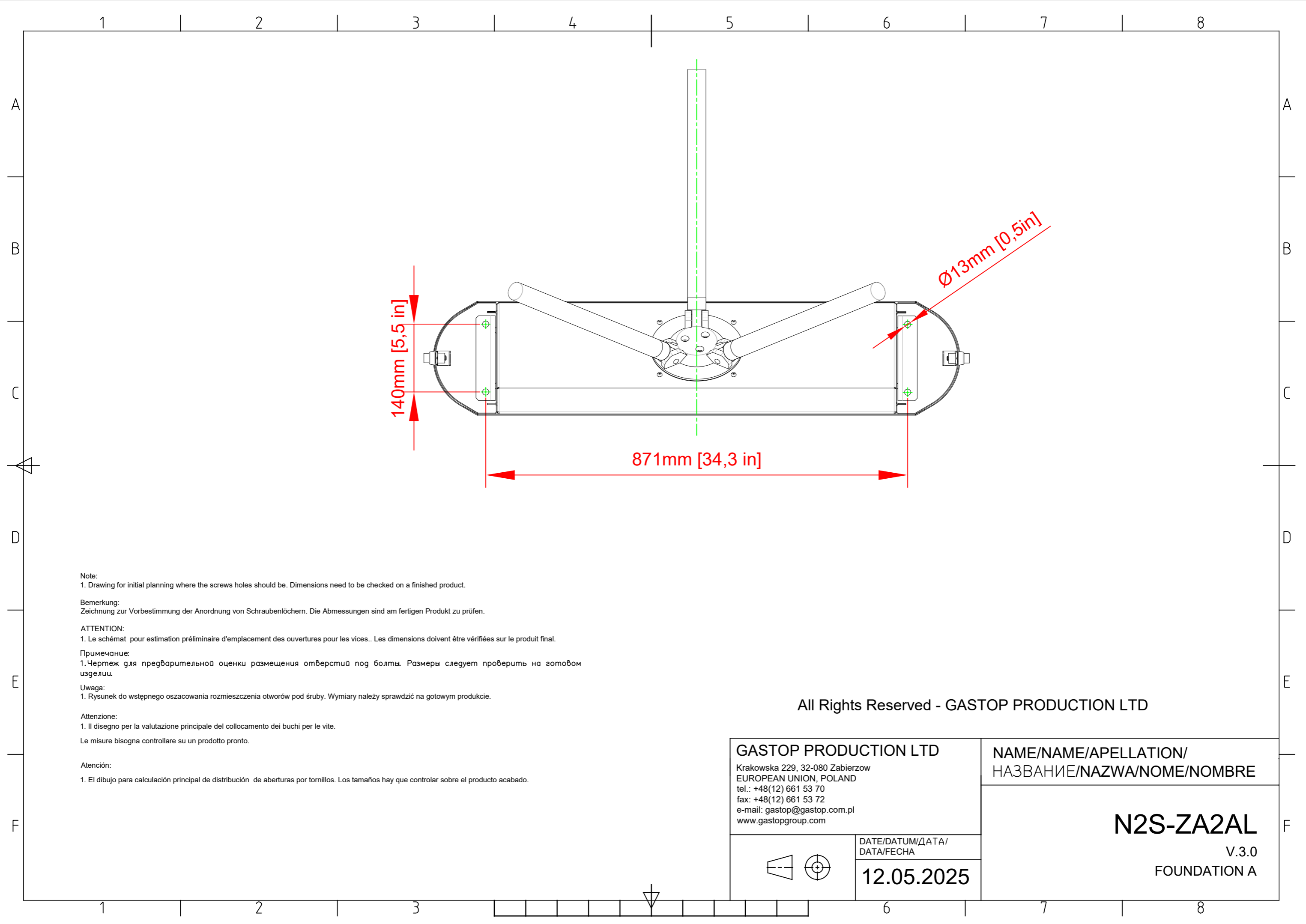

**Note:**  
 1. Drawing for initial planning where the screws holes should be. Dimensions need to be checked on a finished product.

**Bemerkung:**  
 Zeichnung zur Vorbestimmung der Anordnung von Schraubenlöchern. Die Abmessungen sind am fertigen Produkt zu prüfen.

**ATTENTION:**  
 1. Le schémat pour estimation préliminaire d'emplacement des ouvertures pour les vices.. Les dimensions doivent être vérifiées sur le produit final.

**Примечание:**  
 1.Чертеж для предварительной оценки размещения отверстий под болты. Размеры следует проверить на готовом изделии.

**Uwaga:**  
 1. Rysunek do wstępnego oszacowania rozmieszczenia otworów pod śruby. Wymiary należy sprawdzić na gotowym produkcie.

**Attenzione:**  
 1. Il disegno per la valutazione principale del collocamento dei buchi per le vite.  
 Le misure bisogna controllare su un prodotto pronto.

**Atención:**  
 1. El dibujo para calculación principal de distribución de aberturas por tornillos. Los tamaños hay que controlar sobre el producto acabado.

All Rights Reserved - GASTOP PRODUCTION LTD

|                                                                                                                                                                                                       |  |                                                                      |
|-------------------------------------------------------------------------------------------------------------------------------------------------------------------------------------------------------|--|----------------------------------------------------------------------|
| <b>GASTOP PRODUCTION LTD</b><br>Krakowska 229, 32-080 Zabierzow<br>EUROPEAN UNION, POLAND<br>tel.: +48(12) 661 53 70<br>fax: +48(12) 661 53 72<br>e-mail: gastop@gastop.com.pl<br>www.gastopgroup.com |  | <b>NAME/NAME/APELLATION/<br/>         НАЗВАНИЕ/NAZWA/NOME/NOMBRE</b> |
|                                                                                                                                                                                                       |  | <b>N2S-ZA2AL</b><br>V.3.0<br>FOUNDATION A                            |
| DATE/DATUM/DATA/<br>DATA/FECHA<br><b>12.05.2025</b>                                                                                                                                                   |  |                                                                      |

1 2 3 4 5 6 7 8

A

A

LEFT DIRECTION/LINKE RICHTUNG/GAUCHE  
/ЛЕВОЕ направление /KIERUNEK  
LEWY/DIREZIONE SINISTRA/DIRECCIÓN IZQUIERDA

RIGHT DIRECTION/RECHTE RICHTUNG/DROIT/  
ПРАВОЕ НАПРАВЛЕНИЕ/KIERUNEK PRAWY/  
DIREZIONE DESTRA/DIRECCIÓN DERECHA

B

B

C

C

D

D

E

E

F

F

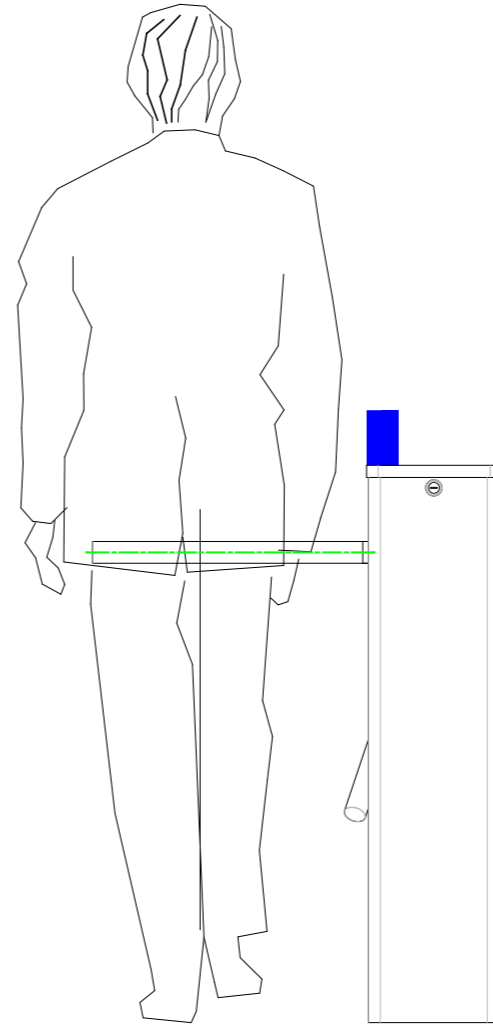
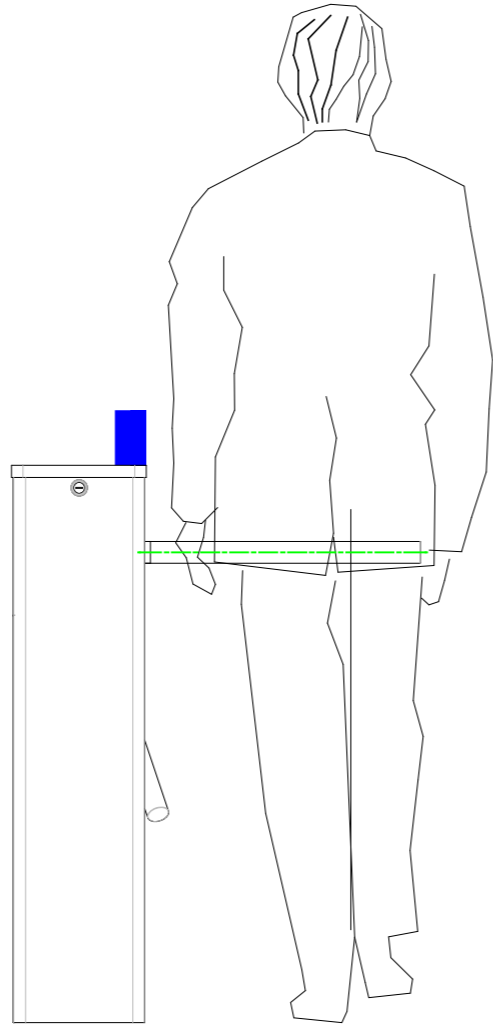

All Rights Reserved - GASTOP PRODUCTION LTD

**GASTOP PRODUCTION LTD**

Krakowska 229, 32-080 Zabierzow  
EUROPEAN UNION, POLAND  
tel.: +48(12) 661 53 70  
fax: +48(12) 661 53 72  
e-mail: gastop@gastop.com.pl  
www.gastopgroup.com

NAME

**N2S-ZA2AL**

V.3.0

INFORMATION

DATE/DATUM/ΔΑΤΑ/  
DATA/FECHA

**12.05.2025**



1 2 3 4 5 6 7 8

1 2 3 4 5 6 7 8

A

A

B

B

C

C

D

D

E

E

F

F

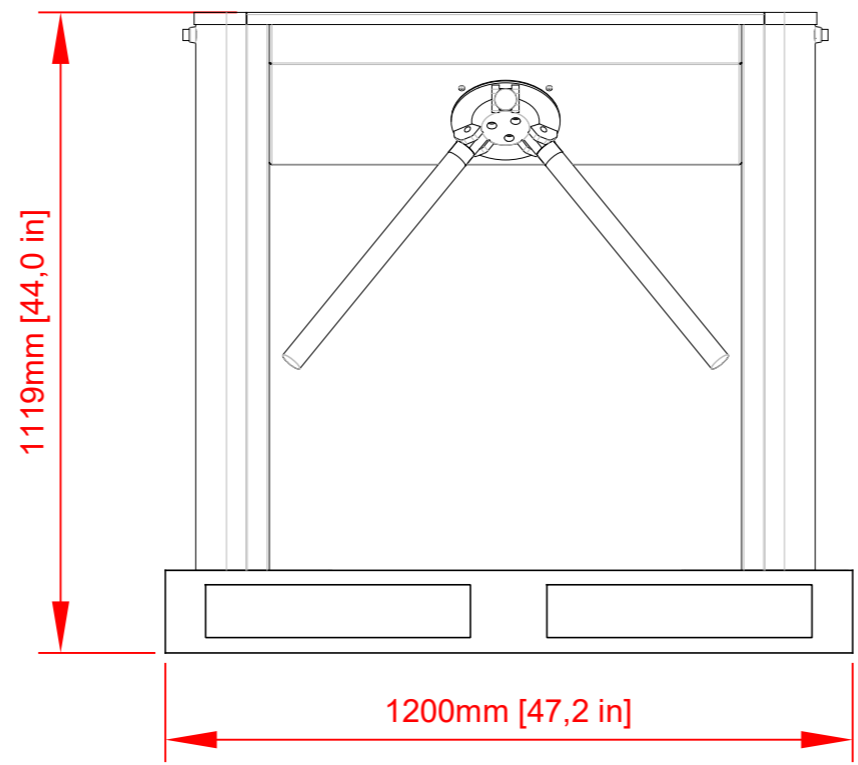

1 X EPAL

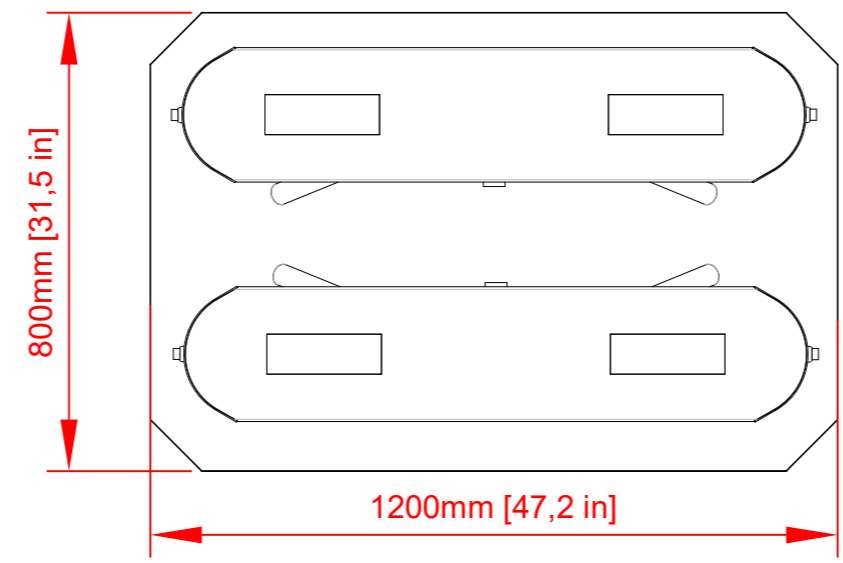

2 X N2S-ZA2AL

All Rights Reserved - GASTOP PRODUCTION LTD

|                                                                                                                                                                       |                                |
|-----------------------------------------------------------------------------------------------------------------------------------------------------------------------|--------------------------------|
| <b>GASTOP PRODUCTION LTD</b>                                                                                                                                          |                                |
| Krakowska 229, 32-080 Zabierzow<br>EUROPEAN UNION, POLAND<br>tel.: +48(12) 661 53 70<br>fax: +48(12) 661 53 72<br>e-mail: gastop@gastop.com.pl<br>www.gastopgroup.com |                                |
|                                                                                                                                                                       | DATE/DATUM/ДАТА/<br>DATA/FECHA |
|                                                                                                                                                                       | <b>12.05.2025</b>              |

|                           |
|---------------------------|
| NAME                      |
| <b>N2S-ZA2AL</b>          |
| V.3.0                     |
| PREPARATION FOR TRANSPORT |

1 2 3 4 5 6 7 8