

BL-2-4

Rysunki

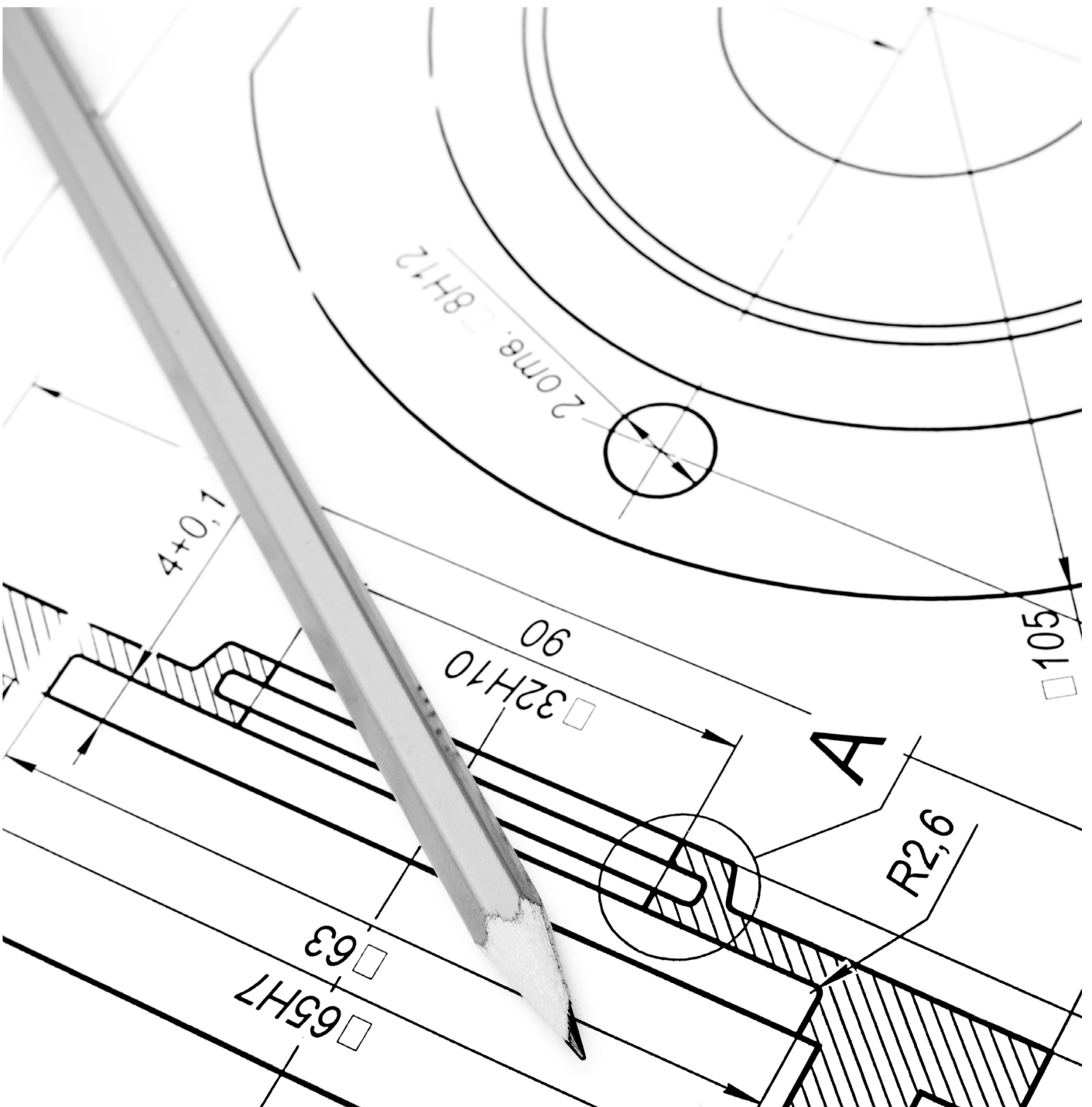

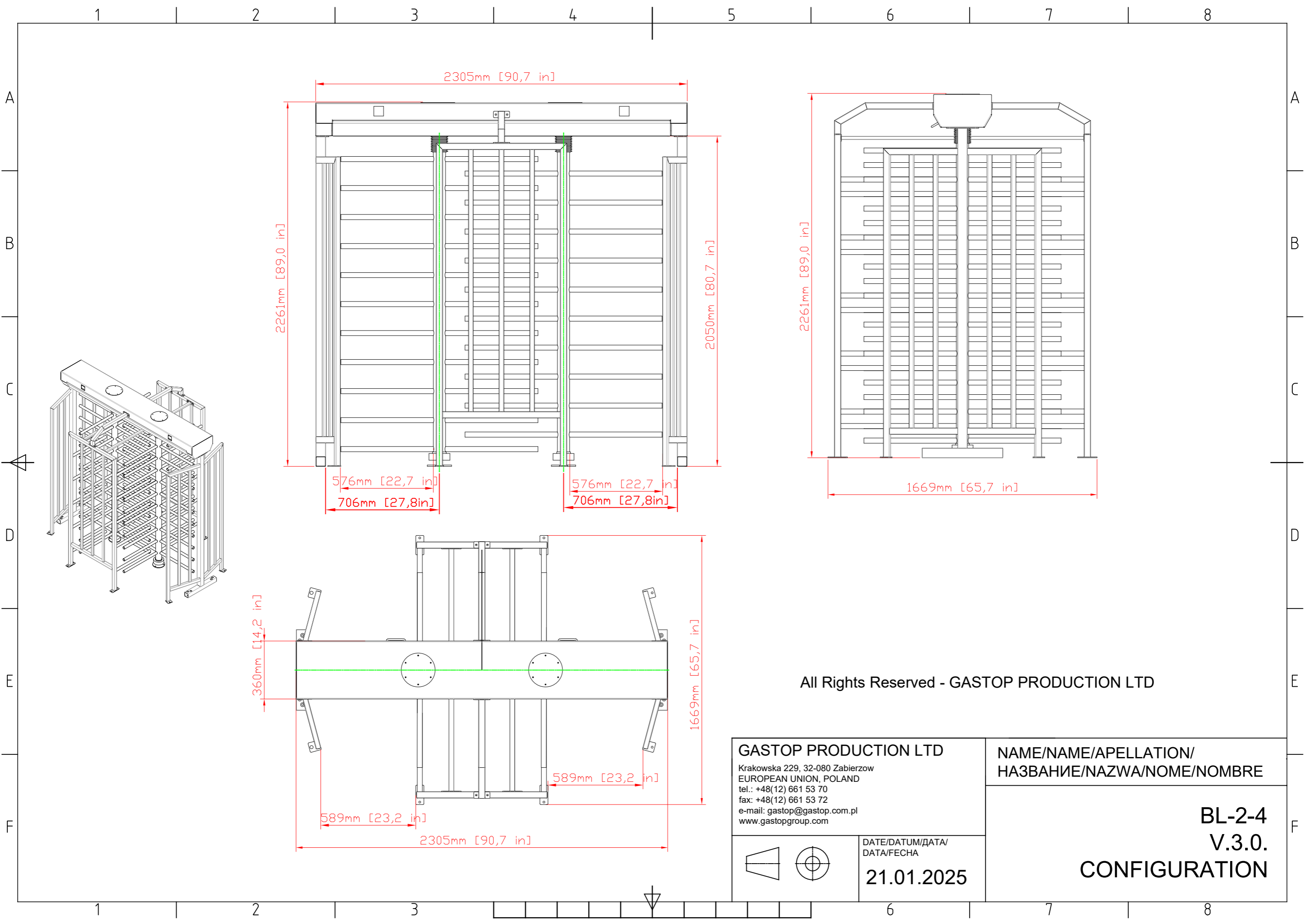

All Rights Reserved - GASTOP PRODUCTION LTD

GASTOP PRODUCTION LTD Krakowska 229, 32-080 Zabierzow EUROPEAN UNION, POLAND tel.: +48(12) 661 53 70 fax: +48(12) 661 53 72 e-mail: gastop@gastop.com.pl www.gastopgroup.com	
	DATE/DATUM/ДАТА/ DATA/FECHA 21.01.2025

NAME/NAME/APELLATION/ НАЗВАНИЕ/NAZWA/NOME/NOMBRE
BL-2-4 V.3.0. CONFIGURATION

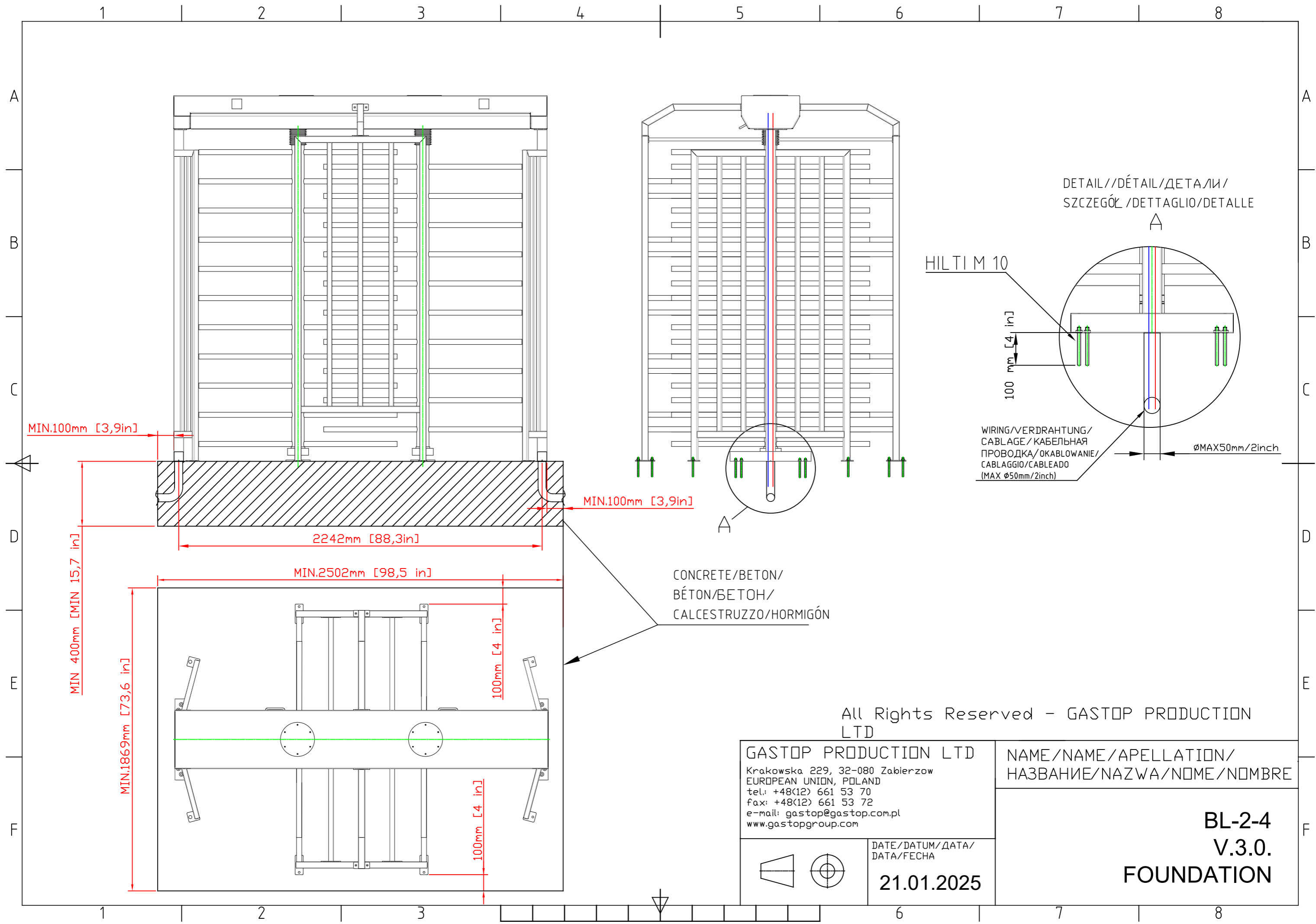

MIN.100mm [3,9in]

MIN.100mm [3,9in]

2242mm [88,3in]

MIN.2502mm [98,5 in]

MIN 400mm [MIN 15,7 in]

MIN.1869mm [73,6 in]

100mm [4 in]

100mm [4 in]

DETAIL//DÉTAIL/ДЕТАЛИ/
SZCZEGÓŁ /DETTAGLIO/DETALLE

HILTI M 10

100 mm [4 in]

WIRING/VERDRÄHTUNG/
CABLAGE/КАБЕЛЬНАЯ
ПРОВОДКА/OKABLOWANIE/
CABLAGGIO/CABLEADO
(MAX Ø50mm/2inch)

ØMAX50mm/2inch

CONCRETE/BETON/
BÉTON/BETON/
CALCESTRUZZO/HORMIGÓN

All Rights Reserved - GASTOP PRODUCTION LTD

GASTOP PRODUCTION LTD

Krakowska 229, 32-080 Zabierzow
EUROPEAN UNION, POLAND
tel: +48(12) 661 53 70
fax: +48(12) 661 53 72
e-mail: gastop@gastop.com.pl
www.gastopgroup.com

NAME/NAME/APELLATION/
НАЗВАНИЕ/NAZWA/NOME/NOMBRE

BL-2-4
V.3.0.
FOUNDATION

DATE/DATUM/DATA/
DATA/FECHA

21.01.2025

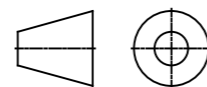

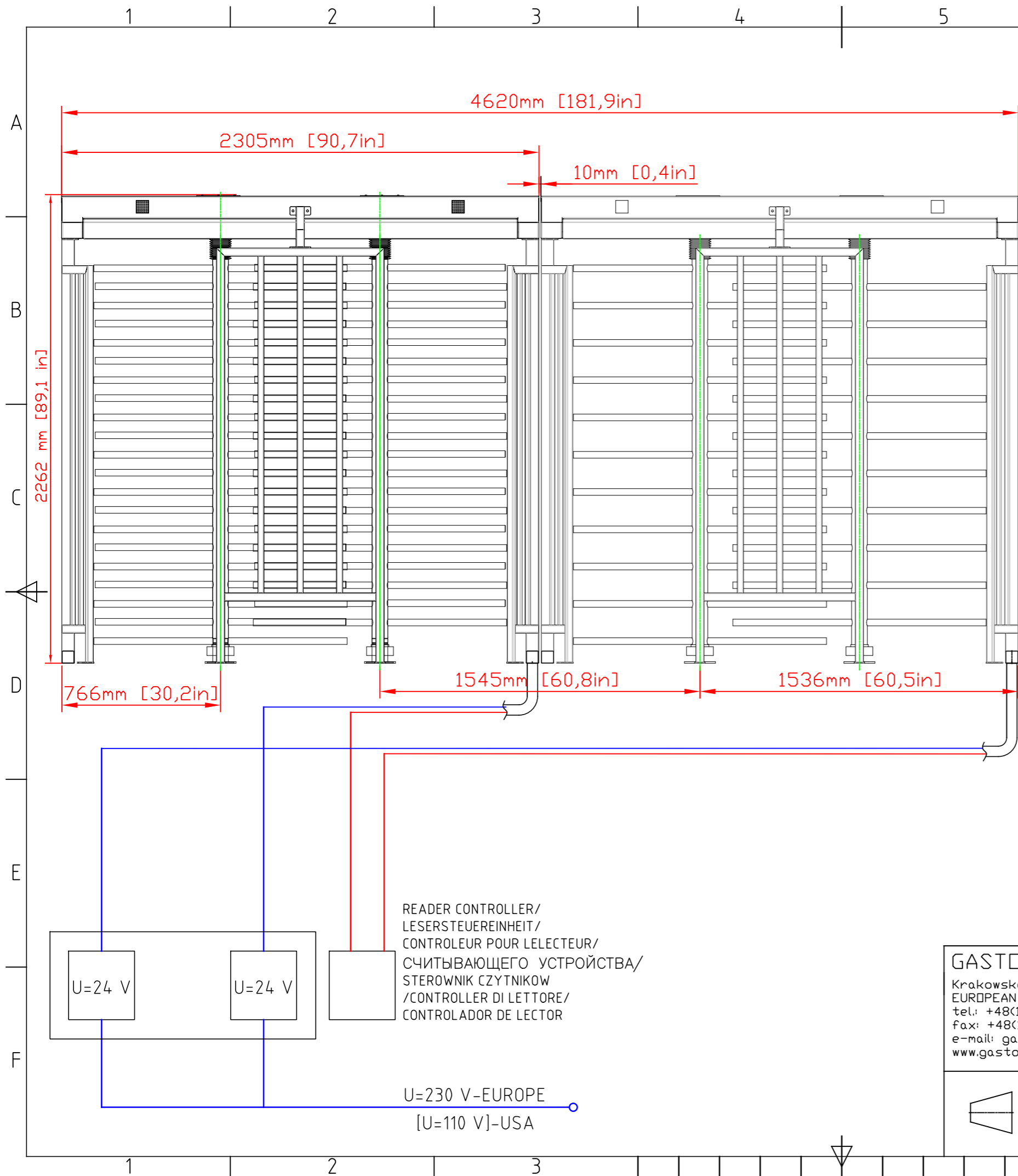

WIRING/VERDRAHTUNG /CABLAGE/КАБЕЛЬНАЯ ПРОВОДКА/ OKABLOWANIE/CABLAGGIO/CABLEADO		
TYPE/MODELL/ТИП/ TYP/TIPO/	FTP	YDYor/oder/ou/или OMY lub/oppure/o
QUANTITY/MENGE/ QUANTITE//СКОЛЬКО/ ILOŚĆ/NUMERO/	6	6
SIZE/GRÖSSE / GABARIT / PAZMEP/ROZMIAR/ TAGLIA/TAMAÑO	8x0.5[mm ²] 8x0.0008[in ²]	L < 50[m] 3x1.5 [mm ²] L < 50[yd]3x0.003[mm ²] L > 50[m] 3x2.5 [mm ²] L > 50[yd]3x0.004[mm ²]

Note

1. Controllers, readers, adaptors, wires, protective pipes are not components of the device.

Bemerkung:

1. Steuereinheiten, Leser, Netzteile, Leitungen, Peschelrohre sind keine Bestandteile der Anlage.

ATTENTION!

1. LECTEURS, CONTROLEURS, PUISSANCE ELECTRIQUE, CABLES, TUYAUX FLEXIBLES, NE SONT PAS COMPOSANTS DU DISPOSITIF.

Примечание:

1. Контроллеры, считывающие устройства, питатели, провода, пешели не являются составными частями оборудования.

Uwaga:

1. Sterowniki, czytniki, zasilacze, przewody, peszle nie stanowią części składowych urządzenia.

Attenzione:

1. Controlleri, lettori, alimentatore, cavi, tubetti non fanno parte delle parti integrate del dispositivo.

Atención:

1. Drivers, lectores, alimentadores, cables, tubos no son parte de componentes del dispositivo.

All Rights Reserved - GASTOP PRODUCTION LTD

GASTOP PRODUCTION LTD
 Krakowska 229, 32-080 Zabierzow
 EUROPEAN UNION, POLAND
 tel.: +48(12) 661 53 70
 fax: +48(12) 661 53 72
 e-mail: gastop@gastop.com.pl
 www.gastopgroup.com

DATE/DATUM/DATA/
DATA/FECHA
21.01.2025

NAME/NAME/APELLATION/
HAZBAHIE/NAZWA/NOME/NOMBRE

**BL-2-4
V.3.0.
INSTALATION**

READER CONTROLLER/
LESERSTEUEREINHEIT/
CONTROLEUR POUR LECTEUR/
СЧИТЫВАЮЩЕГО УСТРОЙСТВА/
STEROWNIK CZYTNIKOW
/CONTROLLER DI LETTORE/
CONTROLADOR DE LECTOR

U=230 V-EUROPE
[U=110 V]-USA

U=24 V

U=24 V

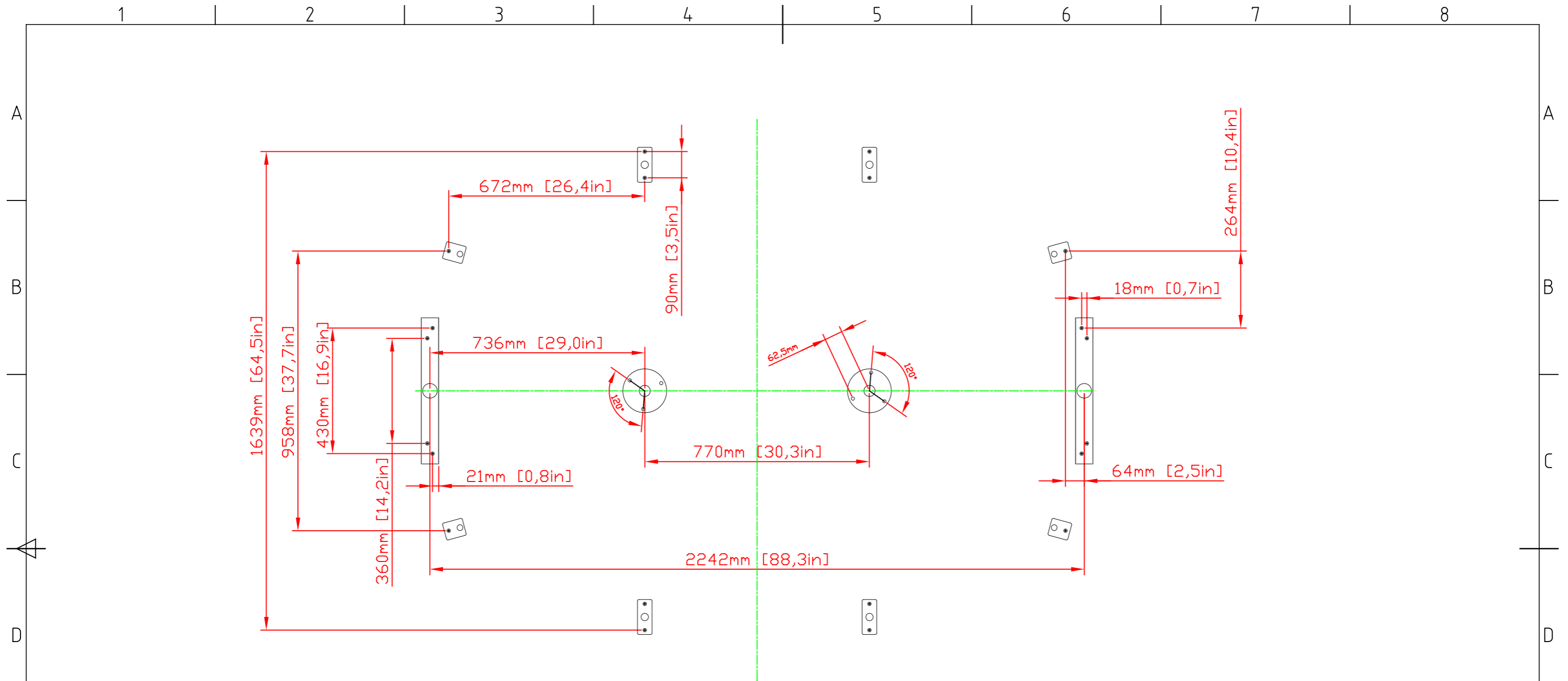

Note:
 1. Drawing for initial planning where the screws holes should be. Dimensions need to be checked on a finished product.

Bemerkung:
 Zeichnung zur Vorbestimmung der Anordnung von Schraubenlöchern. Die Abmessungen sind am fertigen Produkt zu prüfen.

ATTENTION:
 1. Le schémat pour estimation préliminaire d'emplacement des ouvertures pour les vices. Les dimensions doivent être vérifiées sur le produit final.

Примечание:
 1.Чертеж для предварительной оценки размещения отверстий под болты. Размеры следует проверить на готовом изделии.

Uwaga:
 1. Rysunek do wstępnego oszacowania rozmieszczenia otworów pod śruby. Wymiary należy sprawdzić na gotowym produkcie.

Attenzione:
 1. Il disegno per la valutazione principale del collocamento dei buchi per le vite. Le misure bisogna controllare su un prodotto pronto.

Atención:
 1. El dibujo para calculación principal de distribución de aberturas por tornillos. Los tamaños hay que controlar sobre el producto acabado.

All Rights Reserved - GASTOP PRODUCTION LTD

GASTOP PRODUCTION LTD Krakowska 229, 32-080 Zabierzow EUROPEAN UNION, POLAND tel.: +48(12) 661 53 70 fax: +48(12) 661 53 72 e-mail: gastop@gastop.com.pl www.gastopgroup.com	NAME
	BL-2-4 V.3.0. PREPARATION FOR TRANSPORT A
	DATE/DATUM/DATA/ DATA/FECHA 21.01.2025

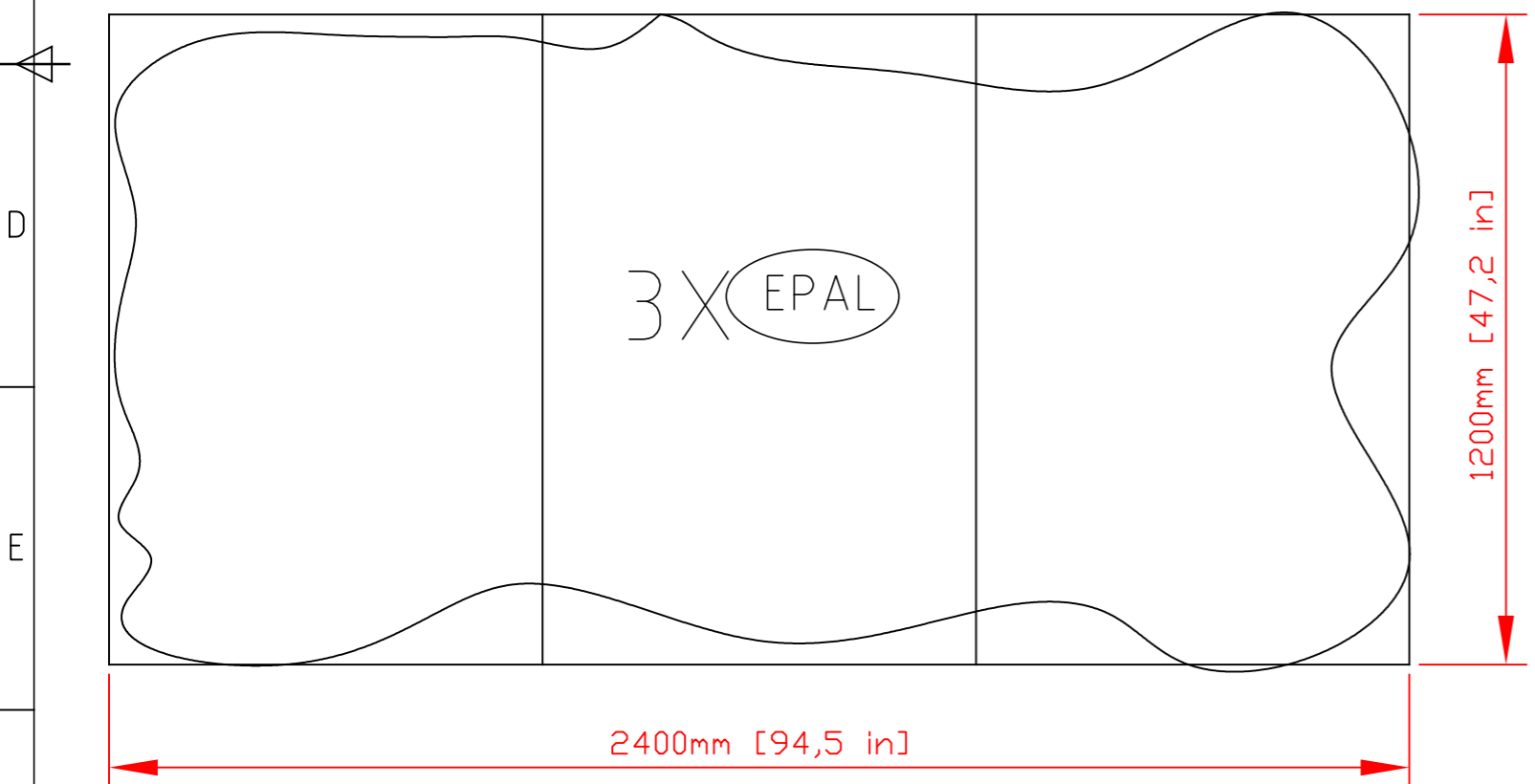
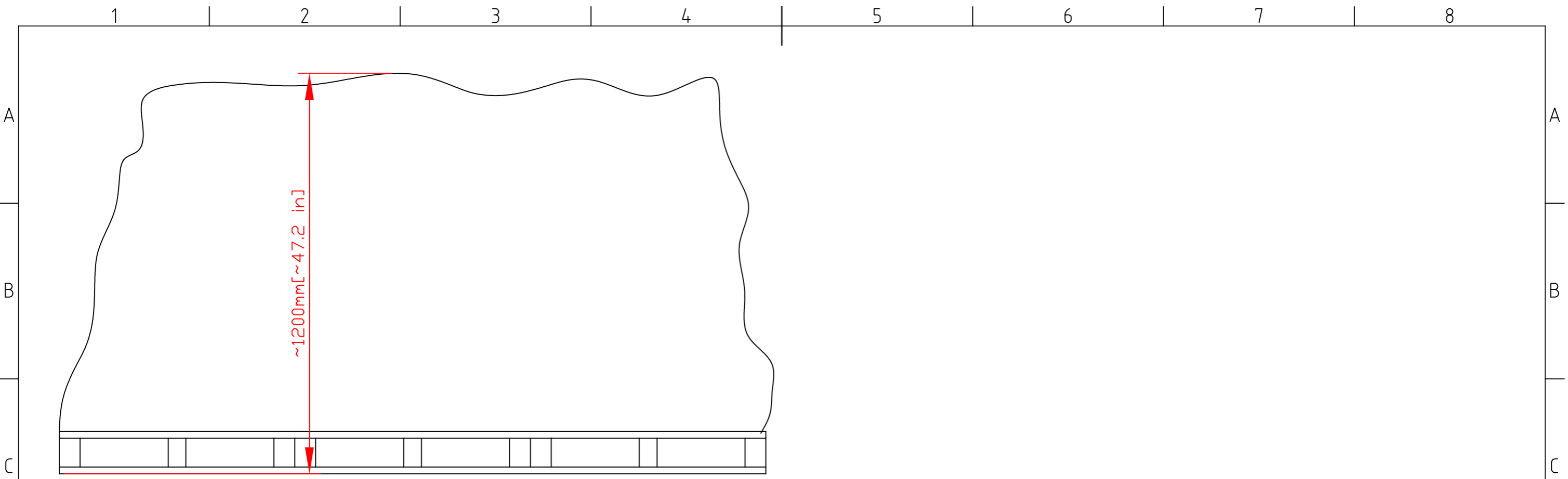

All Rights Reserved - GASTOP PRODUCTION LTD

GASTOP PRODUCTION LTD Krakowska 229, 32-080 Zabierzow EUROPEAN UNION, POLAND tel: +48(12) 661 53 70 fax: +48(12) 661 53 72 e-mail: gastop@gastop.com.pl www.gastopgroup.com	NAME
	BL-2-4
DATE/DATUM/DATA/ DATA/FECHA 21.01.2025	V.3.0.
PREPARATION FOR TRANSPORT	

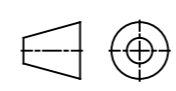

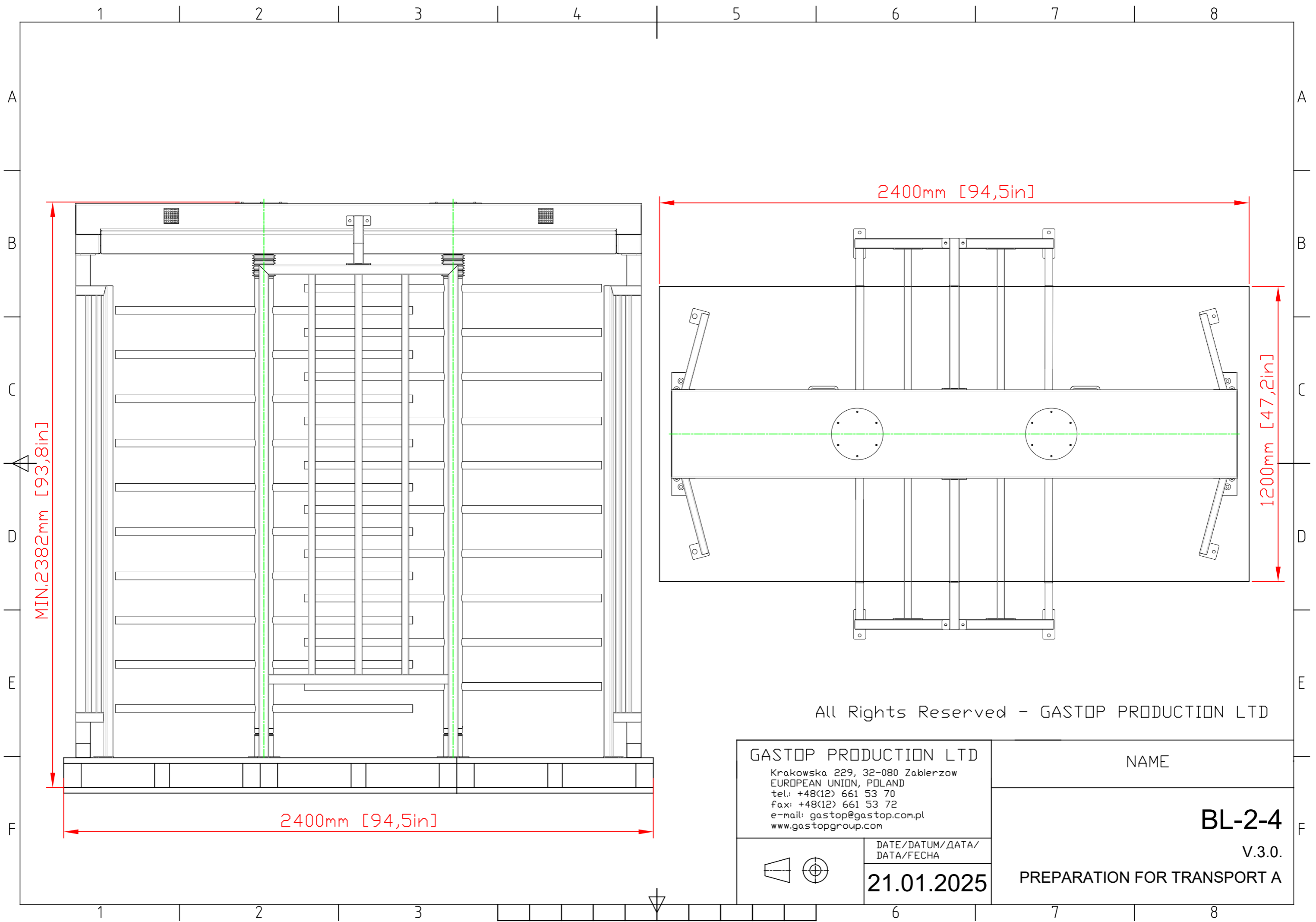

MIN.2382mm [93,8in]

2400mm [94,5in]

1200mm [47,2in]

2400mm [94,5in]

All Rights Reserved - GASTOP PRODUCTION LTD

GASTOP PRODUCTION LTD
 Krakowska 229, 32-080 Zabierzow
 EUROPEAN UNION, POLAND
 tel.: +48(12) 661 53 70
 fax: +48(12) 661 53 72
 e-mail: gastop@gastop.com.pl
 www.gastopgroup.com

DATE/DATUM/DATA/
 DATA/FECHA
21.01.2025

NAME

BL-2-4
 V.3.0.
 PREPARATION FOR TRANSPORT A

