



HR-1-A2S

TECHNICAL DRAWINGS

ALL RIGHTS RESERVED BY GASTOP PRODUCTION LTD

03.2026

1 2 3 4 5 6 7 8

A
B
C
D
E
F

A
B
C
D
E
F

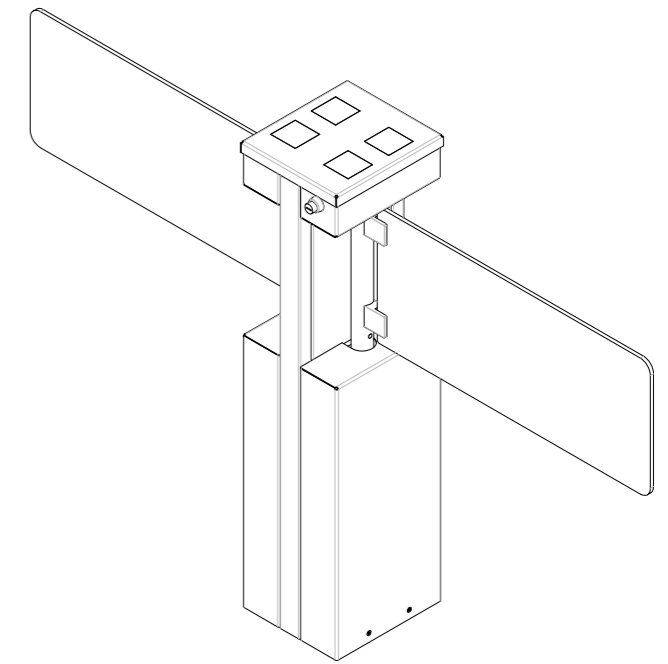
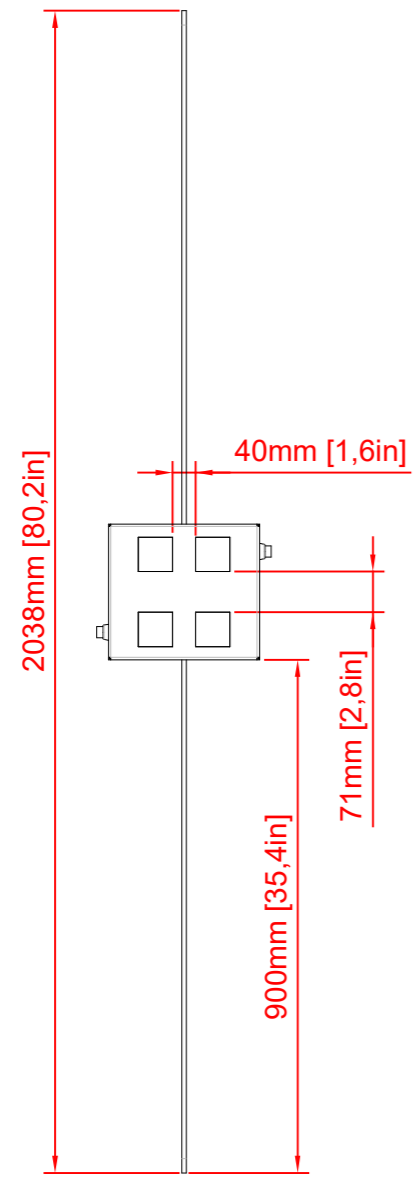
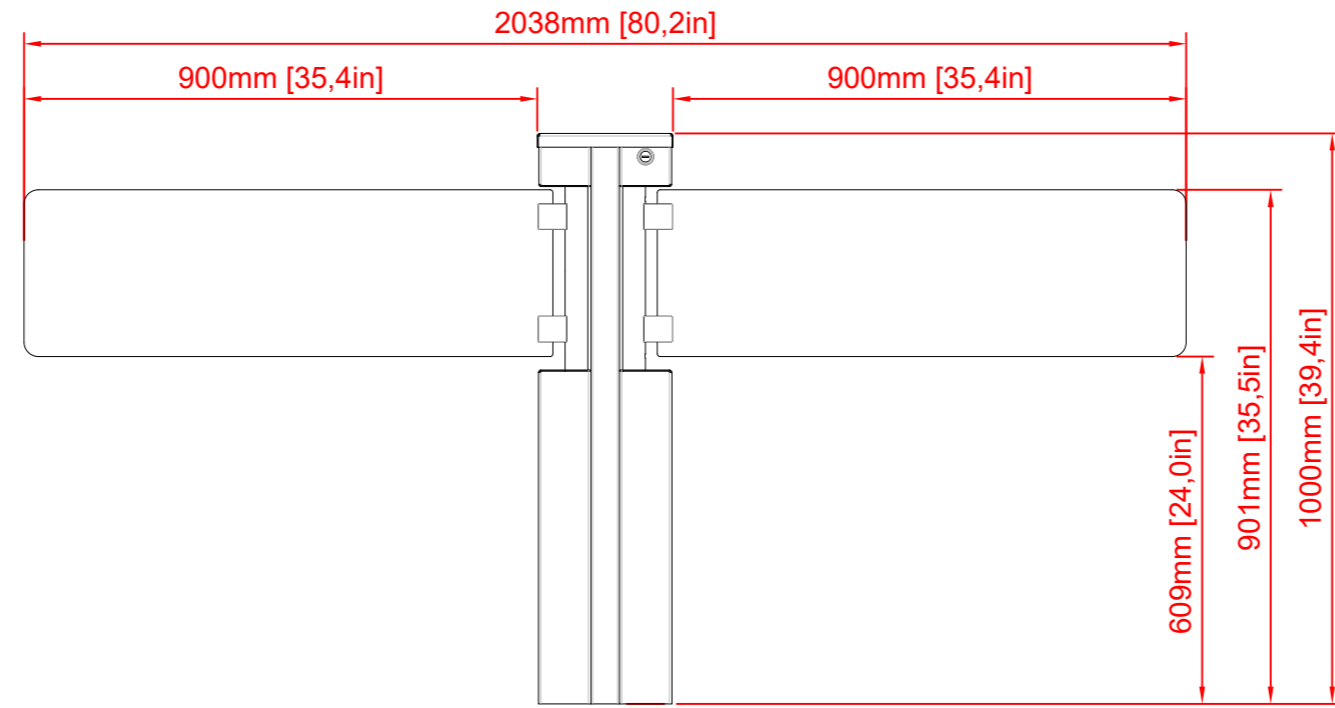
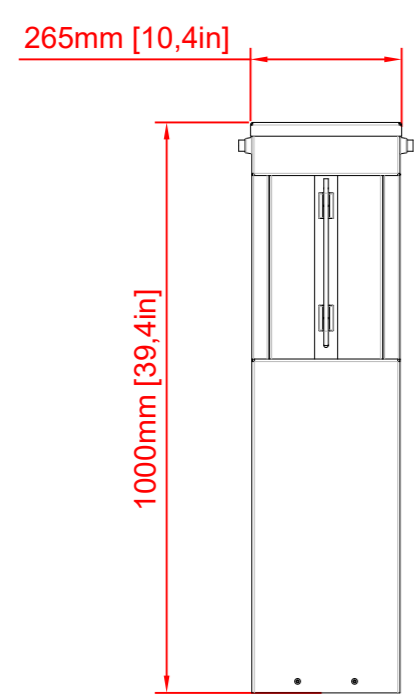

All Rights Reserved - GASTOP PRODUCTION LTD

GASTOP PRODUCTION LTD Krakowska 229, 32-080 Zabierzow EUROPEAN UNION, POLAND tel.: +48(12) 661 53 70 fax: +48(12) 661 53 72 e-mail: gastop@gastop.com.pl www.gastopgroup.com	
	DATE/DATUM/DATA/ DATA/FECHA
	04.03.2026

NAME
HR-1-A2S CONFIGURATION

1 2 3 4 5 6 7 8

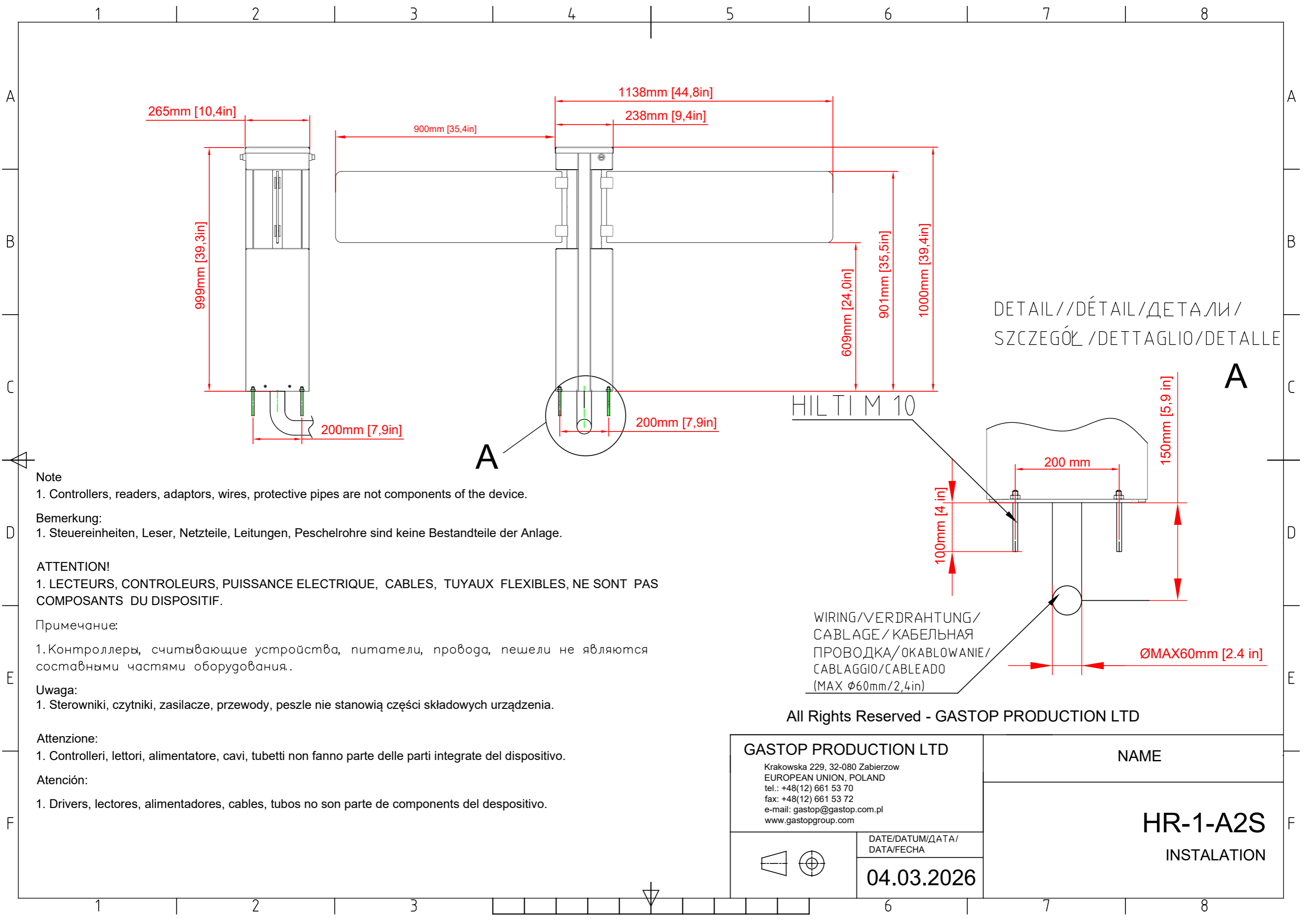

DETAIL//DÉTAIL/ДЕТАЛИ/
SZCZEGÓŁ /DETTAGLIO/DETALLE

- Note
1. Controllers, readers, adaptors, wires, protective pipes are not components of the device.
- Bemerkung:
1. Steuereinheiten, Leser, Netzteile, Leitungen, Peschelrohre sind keine Bestandteile der Anlage.
- ATTENTION!
1. LECTEURS, CONTROLEURS, PUISSANCE ELECTRIQUE, CABLES, TUYAUX FLEXIBLES, NE SONT PAS COMPOSANTS DU DISPOSITIF.
- Примечание:
1. Контроллеры, считывающие устройства, питатели, провода, пещели не являются составными частями оборудования.
- Uwaga:
1. Sterowniki, czytniki, zasilacze, przewody, peszle nie stanowią części składowych urządzenia.
- Attenzione:
1. Controlleri, lettori, alimentatore, cavi, tubetti non fanno parte delle parti integrate del dispositivo.
- Atención:
1. Drivers, lectores, alimentadores, cables, tubos no son parte de componentes del dispositivo.

HILTI M 10

WIRING/VERDRAHTUNG/
CABLAGE / KABELNAYA
PROWODKA/OKABLOWANIE/
CABLAGGIO/CABLEADO
(MAX Ø60mm/2,4in)

All Rights Reserved - GASTOP PRODUCTION LTD

GASTOP PRODUCTION LTD Krakowska 229, 32-080 Zabierzow EUROPEAN UNION, POLAND tel.: +48(12) 661 53 70 fax: +48(12) 661 53 72 e-mail: gastop@gastop.com.pl www.gastopgroup.com	NAME
	HR-1-A2S INSTALATION
	DATE/DATUM/DATA/ DATA/FECHA
04.03.2026	

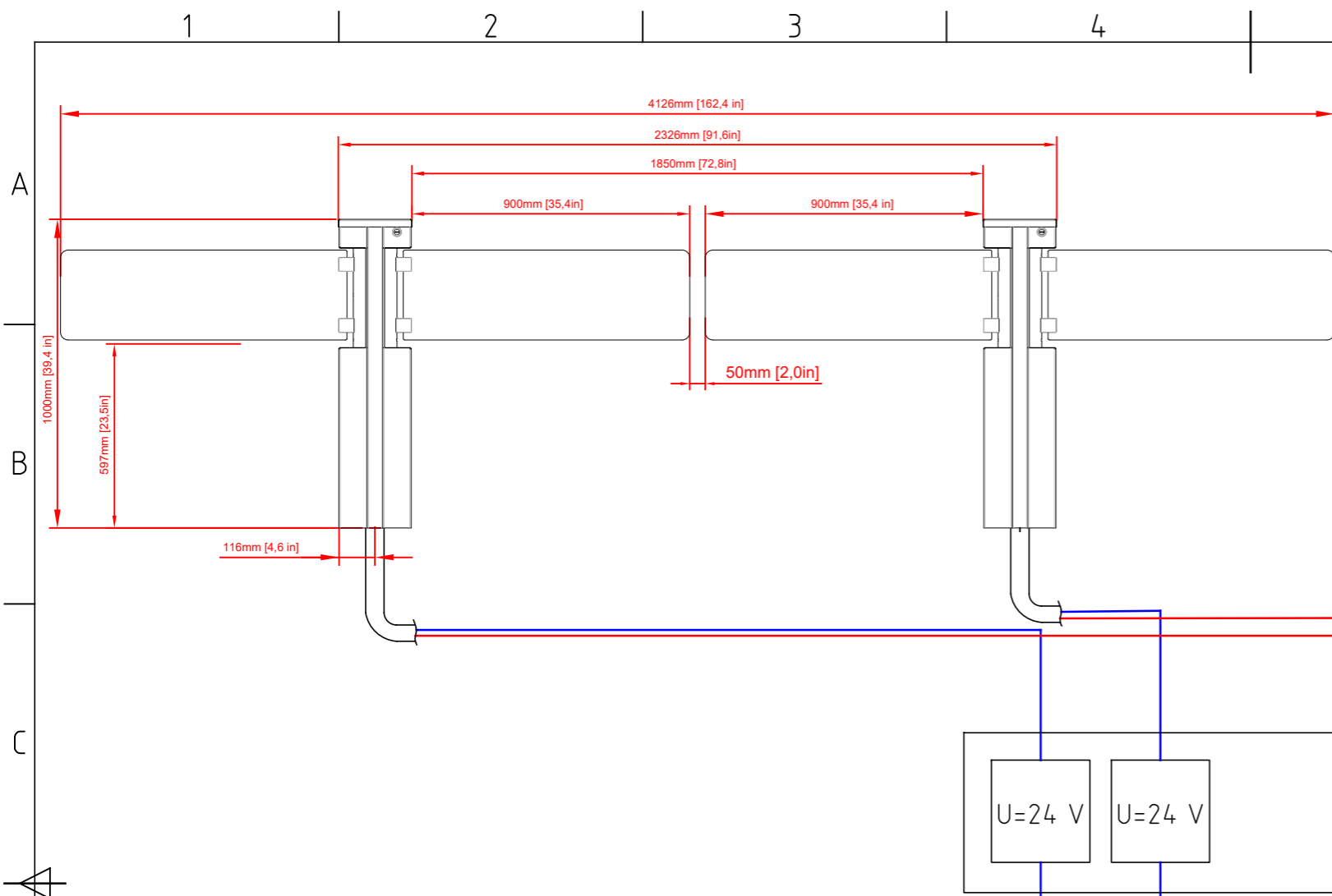

WIRING/VERDRÄHTUNG/CABLAGE/КАБЕЛЬНАЯ ПРОВОДКА/OKABLOWANIE/CABLAGGIO/CABLEADO		
TYPE/MODELL/ТИП/ TYP/TIPO/	FTP	YDYor/oder/ou/или/ lub/opppure/OMY
QUANTITY/MENGE/ QUANTITE//СКОЛЬКО/ ILOŚĆ/NUMERO/	4	4
SIZE/GRÖSSE / GABARIT / PAZMEP/ROZMIAR/ TAGLIA/TAMAÑO	8x0.5 [mm ²]	L < 50[m] L < 164[ft]
	8x20 [AWG]	L > 50[m] L > 164[ft]
		3x1.5 [mm ²] 3x16 [AWG]
		3x2.5 [mm ²] 3x14[AWG]

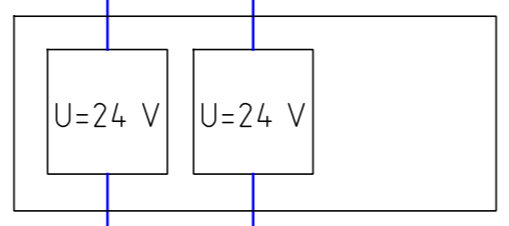

U=230 V-EUROPE
[U=110 V]-USA

READER CONTROLLER/
LESERSTEUEREINHEIT/
CONTROLEUR POUR LECTEUR/
СЧИТЫВАЮЩЕГО УСТРОЙСТВА/
STEROWNIK CZYTNIKOW
/CONTROLLER DI LETTORE/
CONTROLADOR DE LECTOR

- Note**
1. Controllers, readers, adaptors, wires, protective pipes are not components of the device.
- Bemerkung:**
1. Steuereinheiten, Leser, Netzteile, Leitungen, Peschelrohre sind keine Bestandteile der Anlage.
- ATTENTION!**
1. LECTEURS, CONTROLEURS, PUISSANCE ELECTRIQUE, CABLES, TUYAUX FLEXIBLES, NE SONT PAS COMPOSANTS DU DISPOSITIF.
- Примечание:**
1. Контроллеры, считывающие устройства, питатели, провода, пешели не являются составными частями оборудования.
- Uwaga:**
1. Sterowniki, czytniki, zasilacze, przewody, peszle nie stanowią części składowych urządzenia.
- Attenzione:**
1. Controlleri, lettori, alimentatore, cavi, tubetti non fanno parte delle parti integrate del dispositivo.
- Atención:**
1. Drivers, lectores, alimentadores, cables, tubos no son parte de componentes del despositivo.

All Rights Reserved - GASTOP PRODUCTION LTD

GASTOP PRODUCTION LTD
Krakowska 229, 32-080 Zabierzow
EUROPEAN UNION, POLAND
tel.: +48(12) 661 53 70
fax: +48(12) 661 53 72
e-mail: gastop@gastop.com.pl
www.gastopgroup.com

DATE/DATUM/DATA/
DATA/FECHA
06.03.2026

NAME/NAME/APELLATION/
HAZBAHIE/NAZWA/NOME/NOMBRE

**HR-1-A2S
INSTALLATION A**

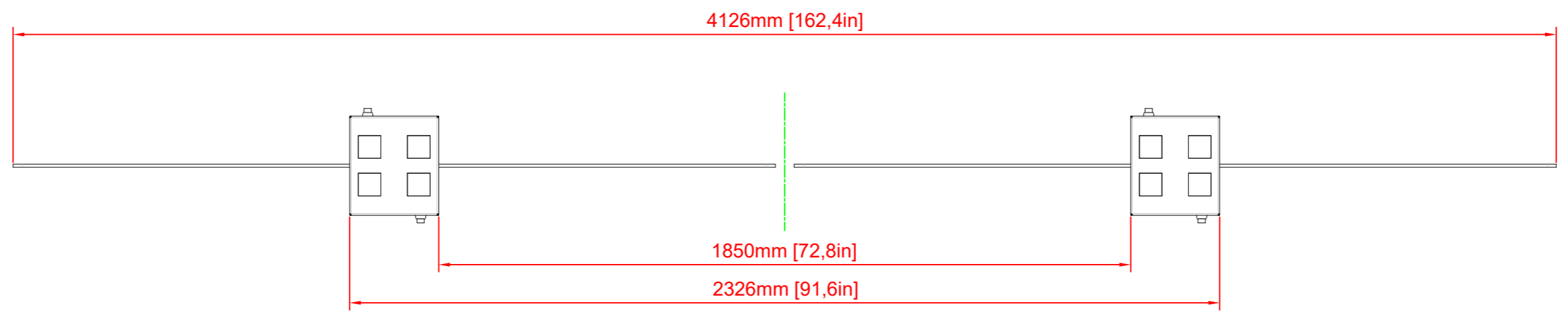
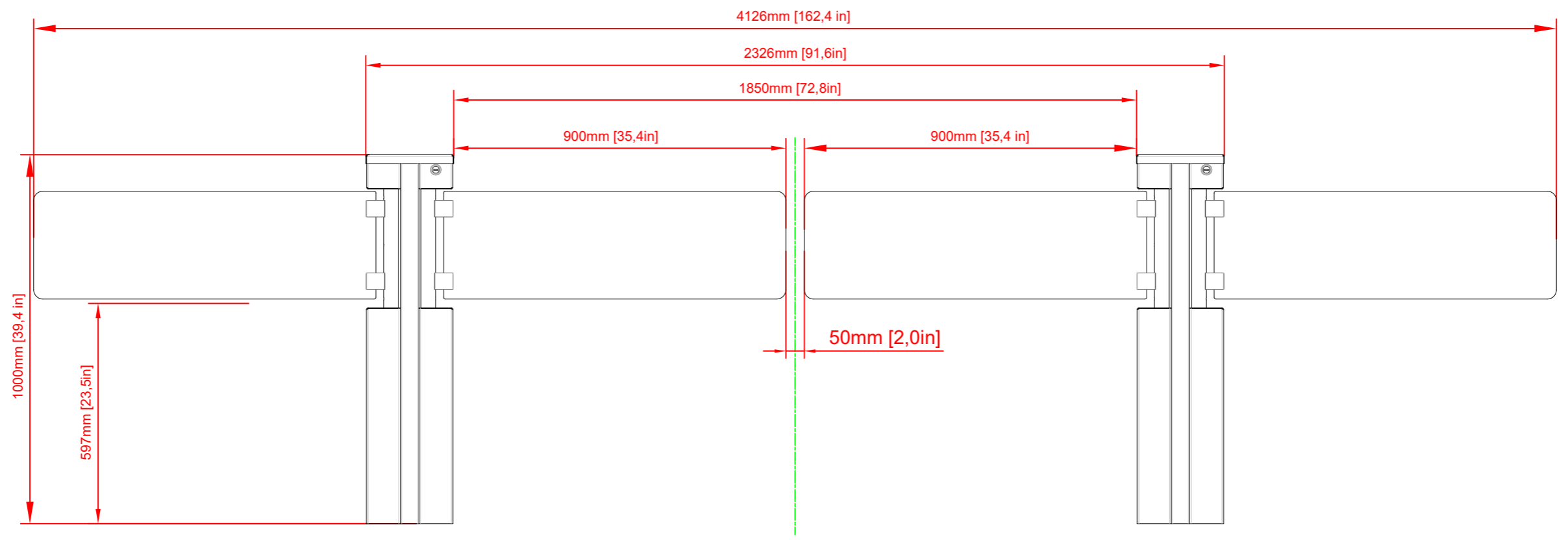

GASTOP PRODUCTION LTD
 Krakowska 229, 32-080 Zabierzow
 EUROPEAN UNION, POLAND
 tel.: +48(12) 661 53 70
 fax: +48(12) 661 53 72
 e-mail: gastop@gastop.com.pl
 www.gastopgroup.com

DATE/DATUM/DATA/
DATA/FECHA
04.03.2026

NAME

HR-1-A2S
 CONFIGURATION A

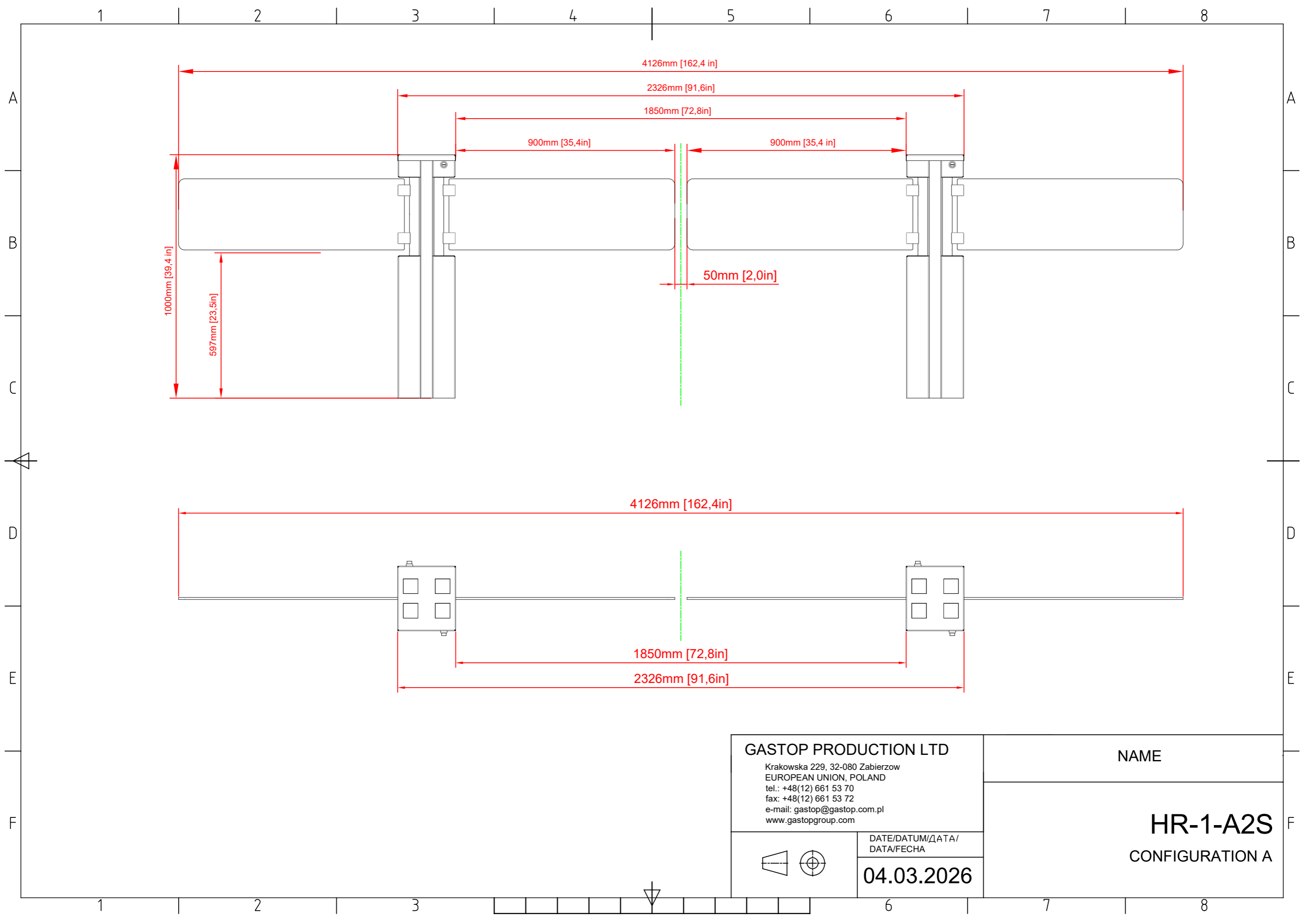

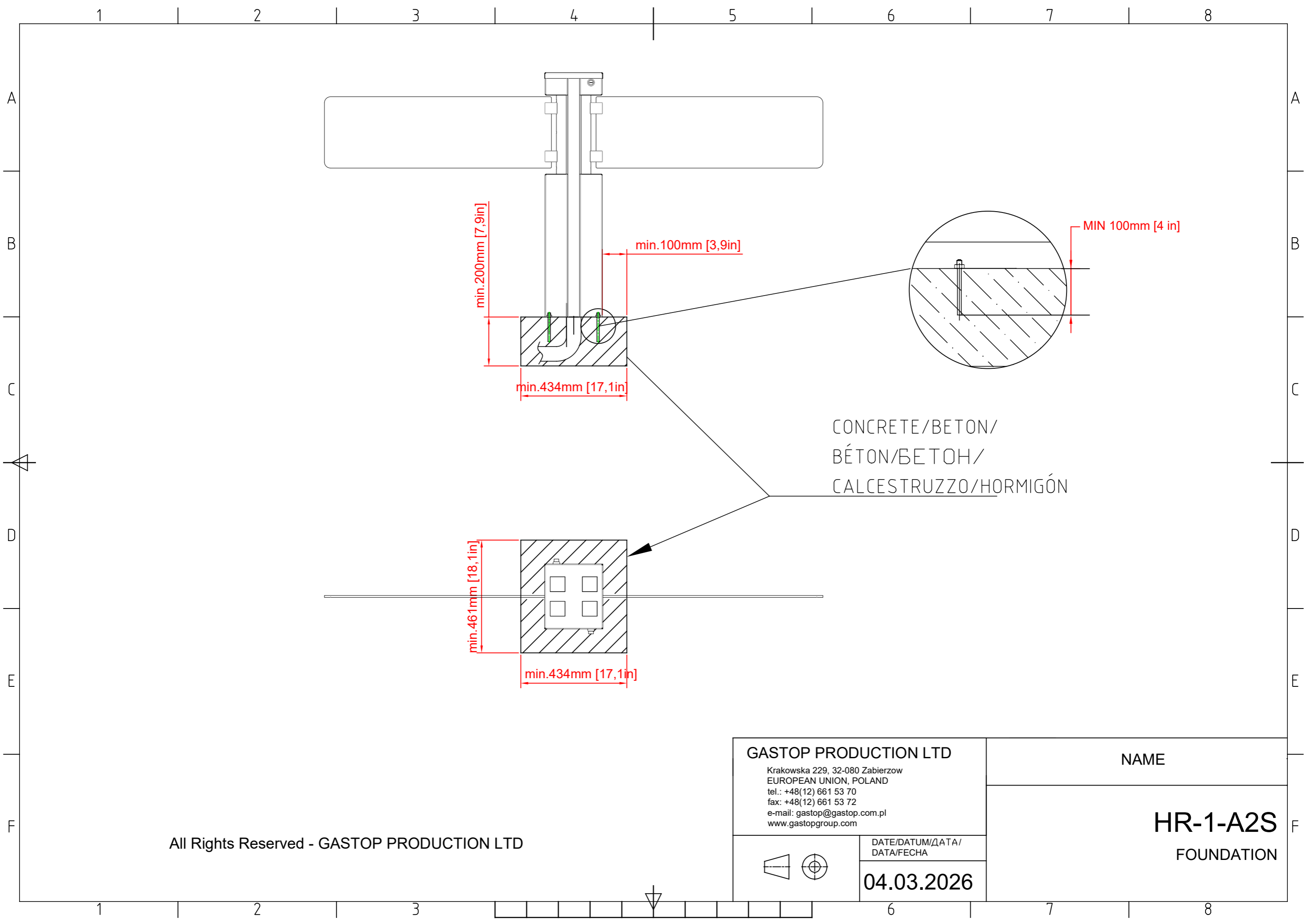

CONCRETE/BETON/
 BÉTON/BETON/
 CALCESTRUZZO/HORMIGÓN

All Rights Reserved - GASTOP PRODUCTION LTD

GASTOP PRODUCTION LTD Krakowska 229, 32-080 Zabierzow EUROPEAN UNION, POLAND tel.: +48(12) 661 53 70 fax: +48(12) 661 53 72 e-mail: gastop@gastop.com.pl www.gastopgroup.com	
	DATE/DATUM/DATA/ DATA/FECHA
	04.03.2026

NAME
HR-1-A2S FOUNDATION

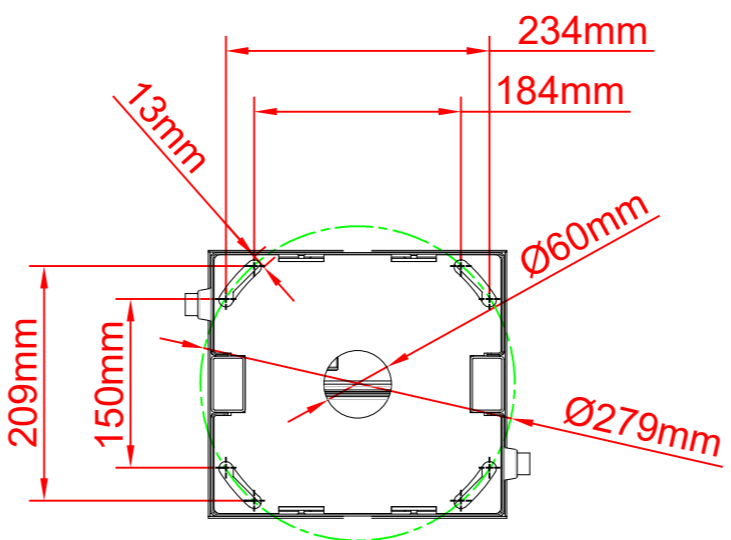

Note:

1. Drawing for initial planning where the screws holes should be. Dimensions need to be checked on a finished product.

Bemerkung:

Zeichnung zur Vorbestimmung der Anordnung von Schraubenlöchern. Die Abmessungen sind am fertigen Produkt zu prüfen.

ATTENTION:

1. Le schémat pour estimation préliminaire d'emplacement des ouvertures pour les vices.. Les dimensions doivent être vérifiées sur le produit final.

Примечание:

1. Чертеж для предварительной оценки размещения отверстий под болты. Размеры следует проверить на готовом изделии.

Uwaga:

1. Rysunek do wstępnego oszacowania rozmieszczenia otworów pod śruby. Wymiary należy sprawdzić na gotowym produkcie.

Attenzione:

1. Il disegno per la valutazione principale del collocamento dei buchi per le vite.

Le misure bisogna controllare su un prodotto pronto.

Atención:

1. El dibujo para calculación principal de distribución de aberturas por tornillos. Los tamaños hay que controlar sobre el producto acabado.

All Rights Reserved - GASTOP PRODUCTION LTD

GASTOP PRODUCTION LTD Krakowska 229, 32-080 Zabierzow EUROPEAN UNION, POLAND tel.: +48(12) 661 53 70 fax: +48(12) 661 53 72 e-mail: gastop@gastop.com.pl www.gastopgroup.com	NAME/NAME/APELLATION/ НАЗВАНИЕ/NAZWA/NOME/NOMBRE
	HR-1-A2S FOUNDATION A
	DATE/DATUM/ДАТА/ DATA/FECHA 04.03.2026

1 2 3 4 5 6 7 8

A

A

LEFT DIRECTION/LINKE RICHTUNG/GAUCHE
/ЛЕВОЕ направление /KIERUNEK
LEWY/DIREZIONE SINISTRA/DIRECCIÓN IZQUIERDA

RIGHT DIRECTION/RECHTE RICHTUNG/DROIT/
ПРАВОЕ НАПРАВЛЕНИЕ/KIERUNEK PRAWY/
DIREZIONE DESTRA/DIRECCIÓN DERECHA

B

B

C

C

D

D

E

E

F

F

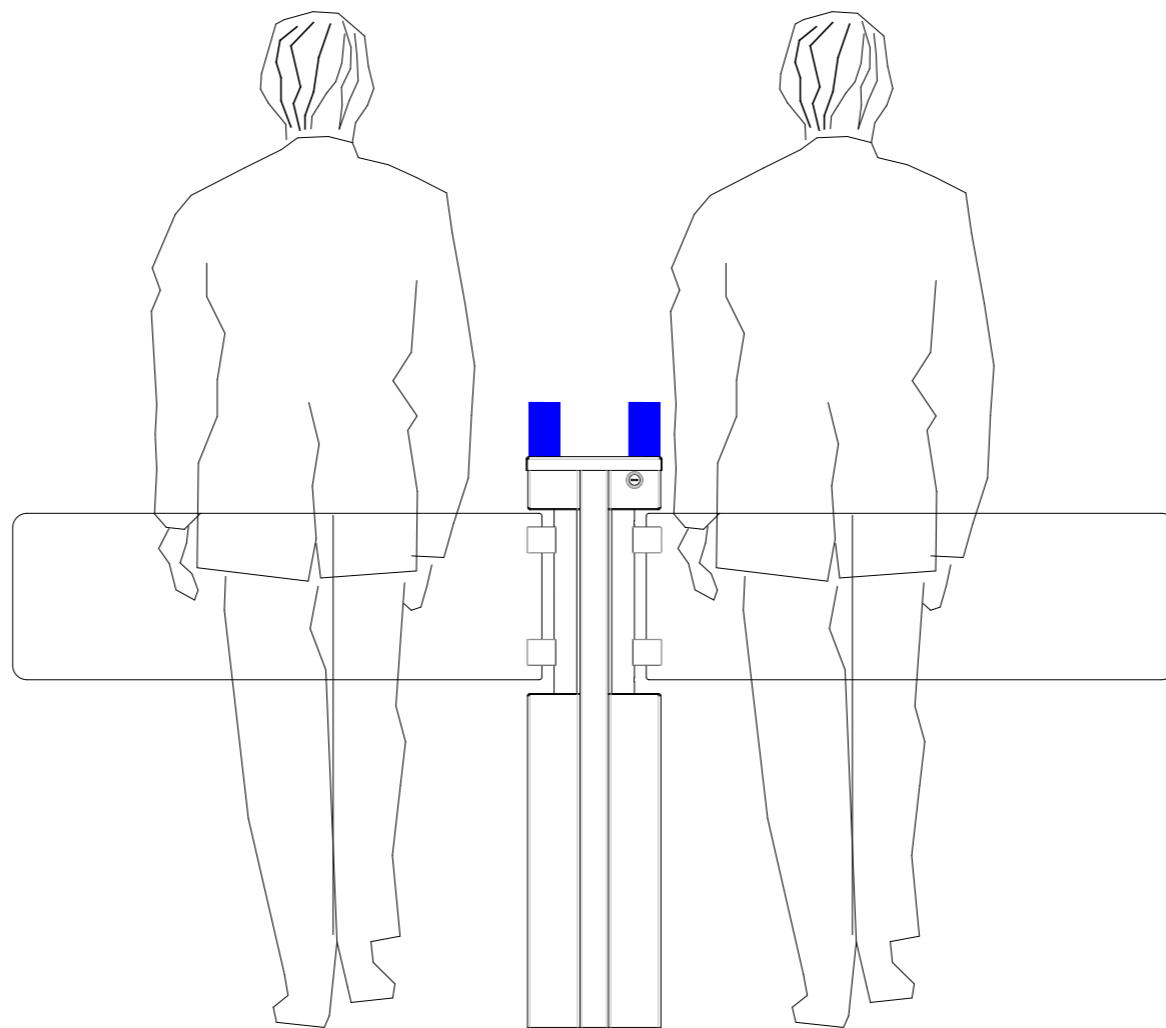

All Rights Reserved - GASTOP PRODUCTION LTD

GASTOP PRODUCTION LTD

Krakowska 229, 32-080 Zabierzow
EUROPEAN UNION, POLAND
tel.: +48(12) 661 53 70
fax: +48(12) 661 53 72
e-mail: gastop@gastop.com.pl
www.gastopgroup.com

NAME

HR-1-A2S

INFORMATION

DATE/DATUM/DATA/
DATA/FECHA

04.03.2026

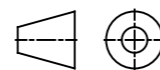

1 2 3 4 5 6 7 8

1 2 3 4 5 6 7 8

A

A

B

B

C

C

D

D

E

E

F

F

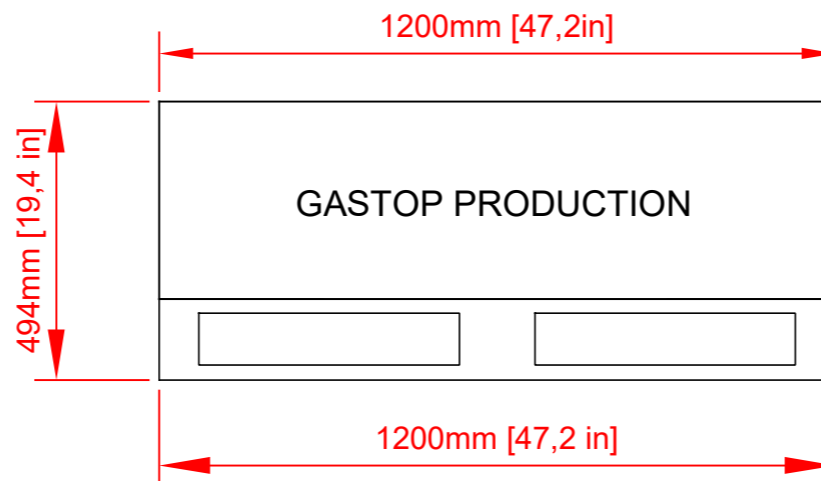

1 X EPAL

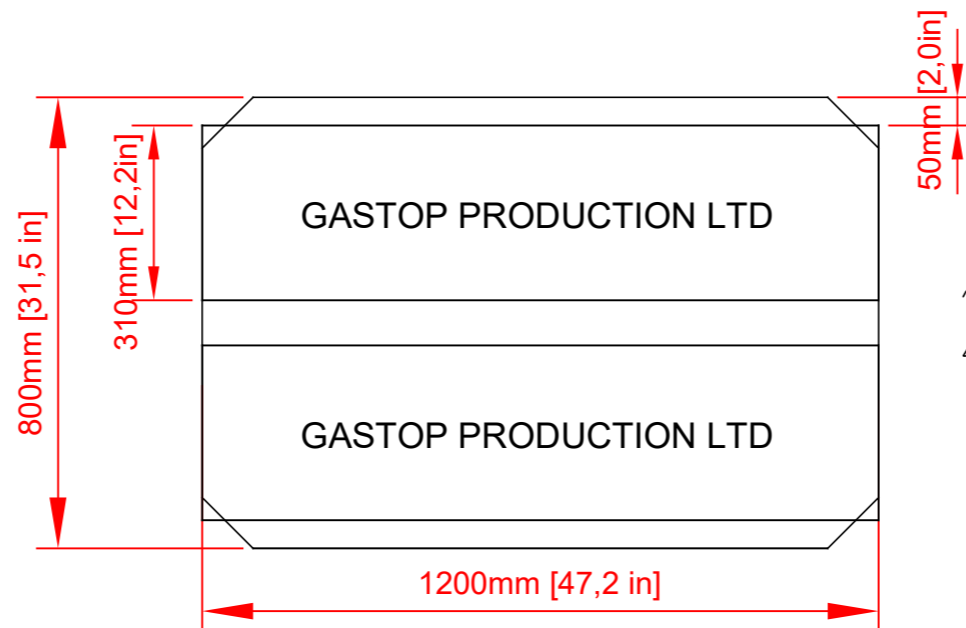

2 X HR-1-A2S

All Rights Reserved - GASTOP PRODUCTION LTD

GASTOP PRODUCTION LTD

Krakowska 229, 32-080 Zabierzow
EUROPEAN UNION, POLAND
tel.: +48(12) 661 53 70
fax: +48(12) 661 53 72
e-mail: gastop@gastop.com.pl
www.gastopgroup.com

NAME

HR-1-A2S

PREPARATION FOR TRANSPORT

DATE/DATUM/DATA/
DATA/FECHA

04.03.2026

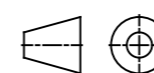

1 2 3 4 5 6 7 8