



BL-2-1

TECHNICAL DRAWINGS

ALL RIGHTS RESERVED BY GASTOP PRODUCTION LTD

03.2026

1 2 3 4 5 6 7 8

A
B
C
D
E
F

A
B
C
D
E
F

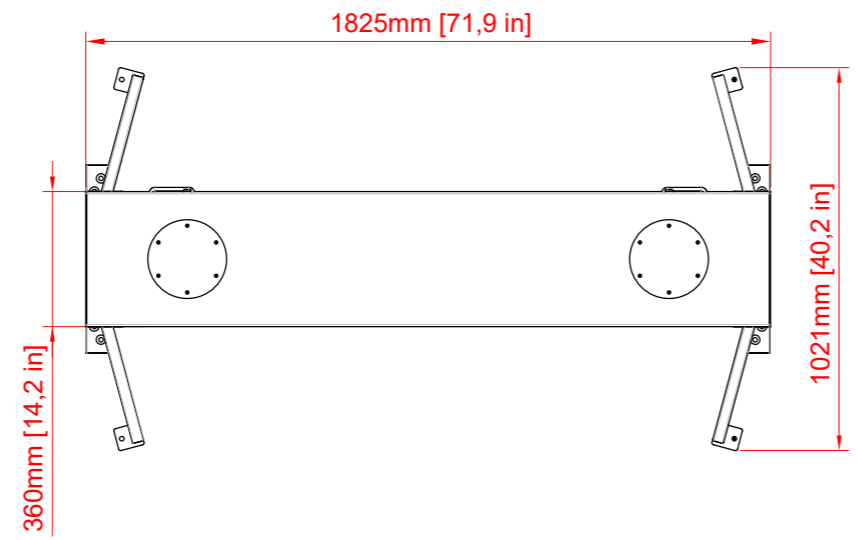
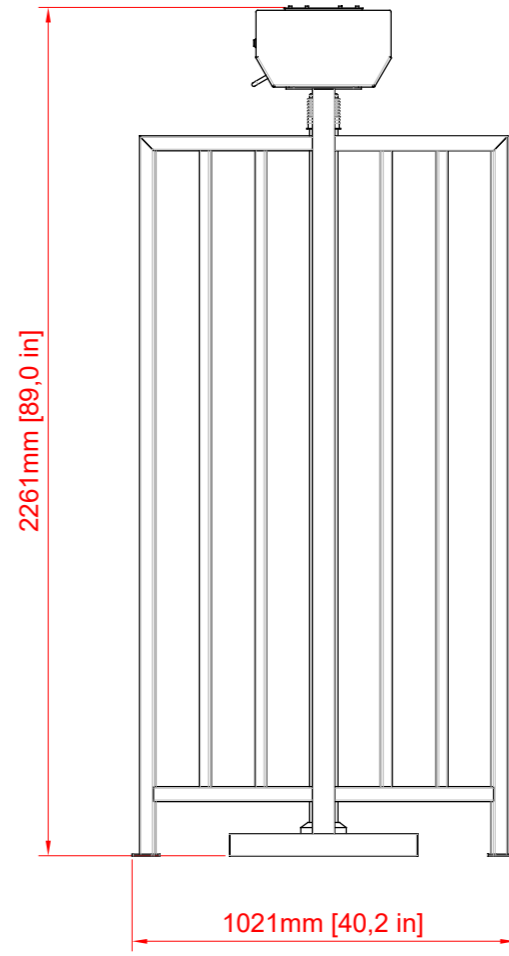
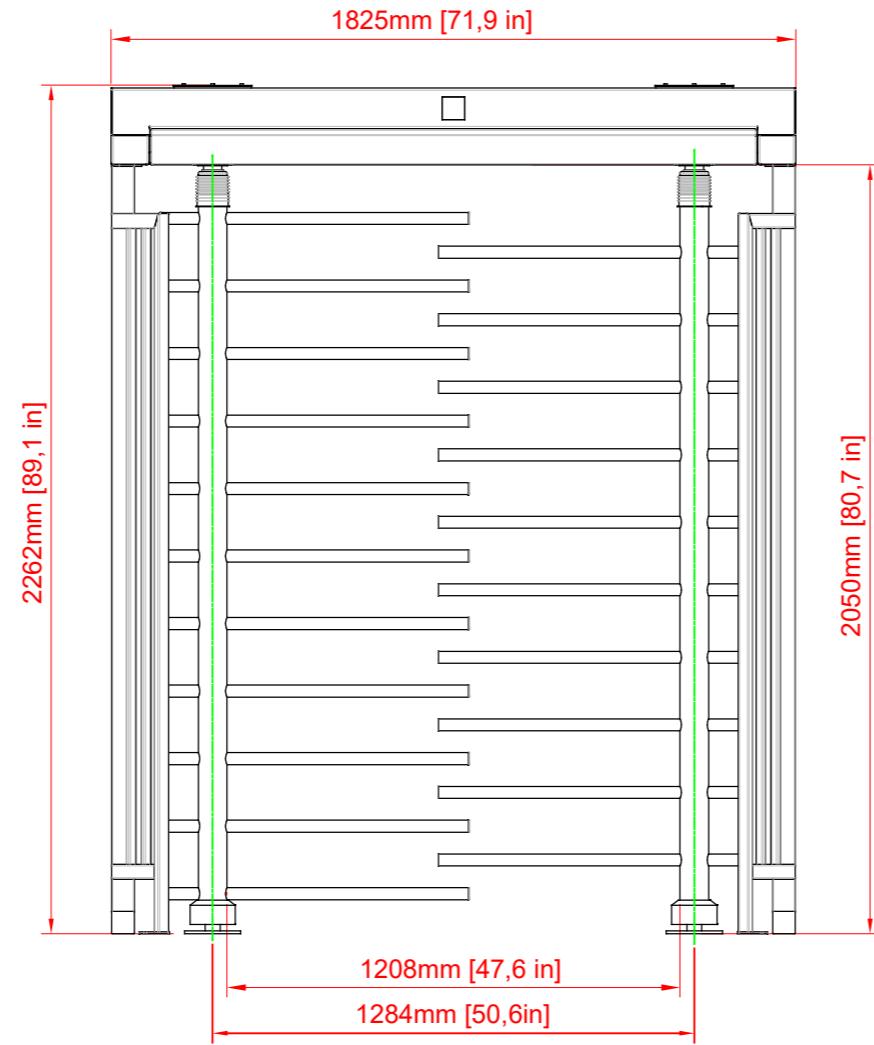
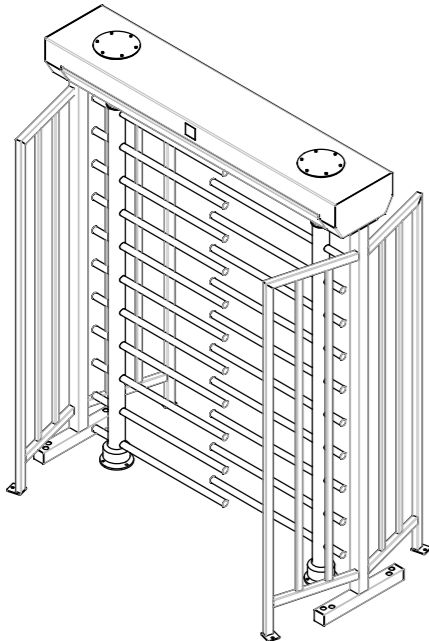

All Rights Reserved - GASTOP PRODUCTION LTD

GASTOP PRODUCTION LTD
 Krakowska 229, 32-080 Zabierzow
 EUROPEAN UNION, POLAND
 tel.: +48(12) 661 53 70
 fax: +48(12) 661 53 72
 e-mail: gastop@gastop.com.pl
 www.gastopgroup.com

DATE/DATUM/DATA/
DATA/FECHA
13.03.2026

NAME/NAME/APELLATION/
НАЗВАНИЕ/NAZWA/NOME/NOMBRE

BL-2-I
CONFIGURATION

1 2 3 4 5 6 7 8

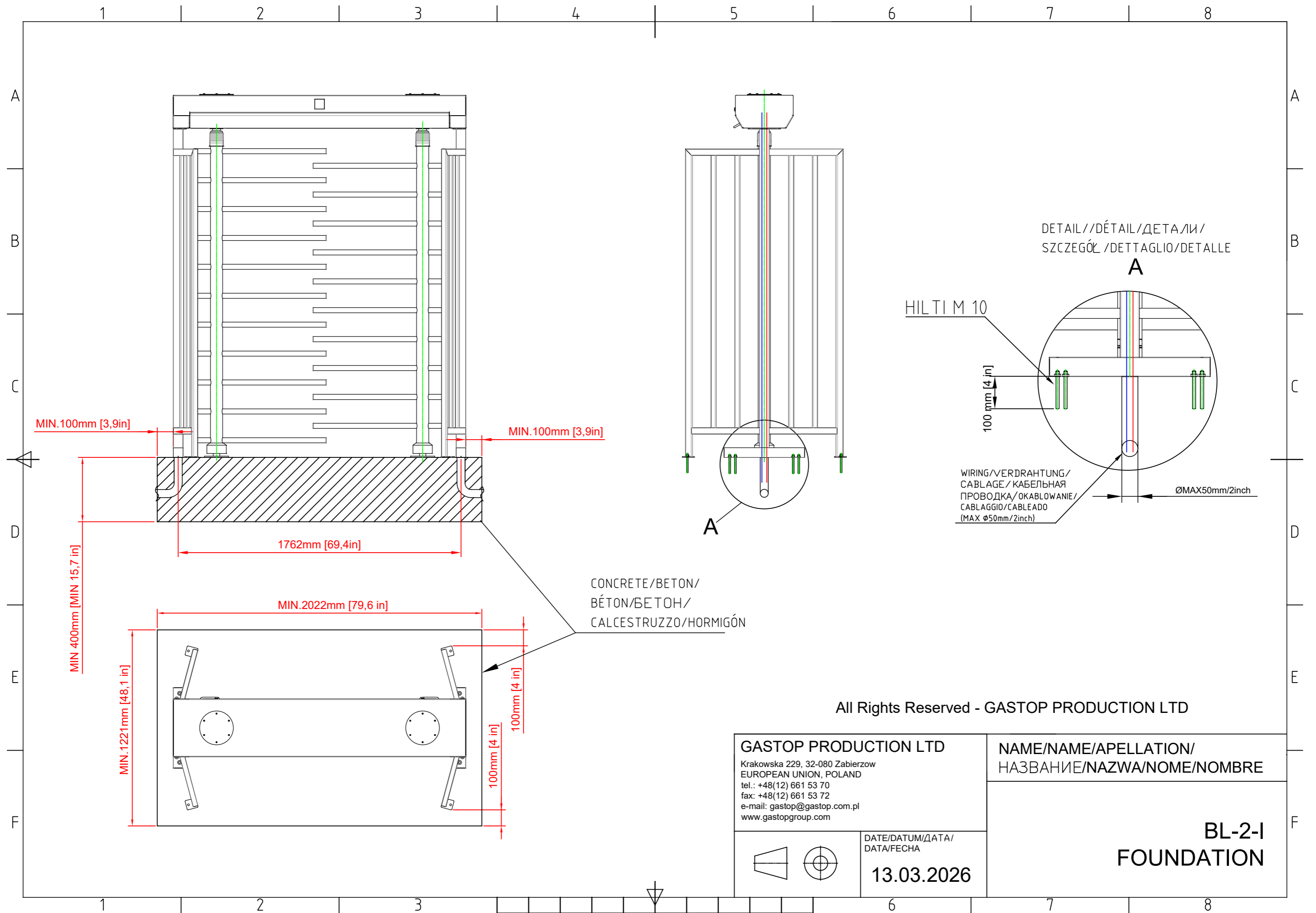

MIN.100mm [3,9in]

MIN.100mm [3,9in]

1762mm [69,4in]

MIN 400mm [MIN 15,7 in]

MIN.2022mm [79,6 in]

MIN.1221mm [48,1 in]

100mm [4 in]
100mm [4 in]

CONCRETE/BETON/
BÉTON/BETON/
CALCESTRUZZO/HORMIGÓN

DETAIL//DÉTAIL/ДЕТАЛИ/
SZCZEGÓŁ /DETTAGLIO/DETALLE

A

HILTI M 10

100 mm [4 in]

WIRING/VERDRAHTUNG/
CABLAGE / КАБЕЛЬНАЯ
ПРОВОДКА/OKABLOWANIE/
CABLAGGIO/CABLEADO
(MAX Ø50mm/2inch)

ØMAX50mm/2inch

All Rights Reserved - GASTOP PRODUCTION LTD

GASTOP PRODUCTION LTD

Krakowska 229, 32-080 Zabierzow
EUROPEAN UNION, POLAND
tel.: +48(12) 661 53 70
fax: +48(12) 661 53 72
e-mail: gastop@gastop.com.pl
www.gastopgroup.com

NAME/NAME/APELLATION/
НАЗВАНИЕ/NAZWA/NOME/NOMBRE

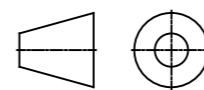

DATE/DATUM/ДАТА/
DATA/FECHA

13.03.2026

BL-2-I
FOUNDATION

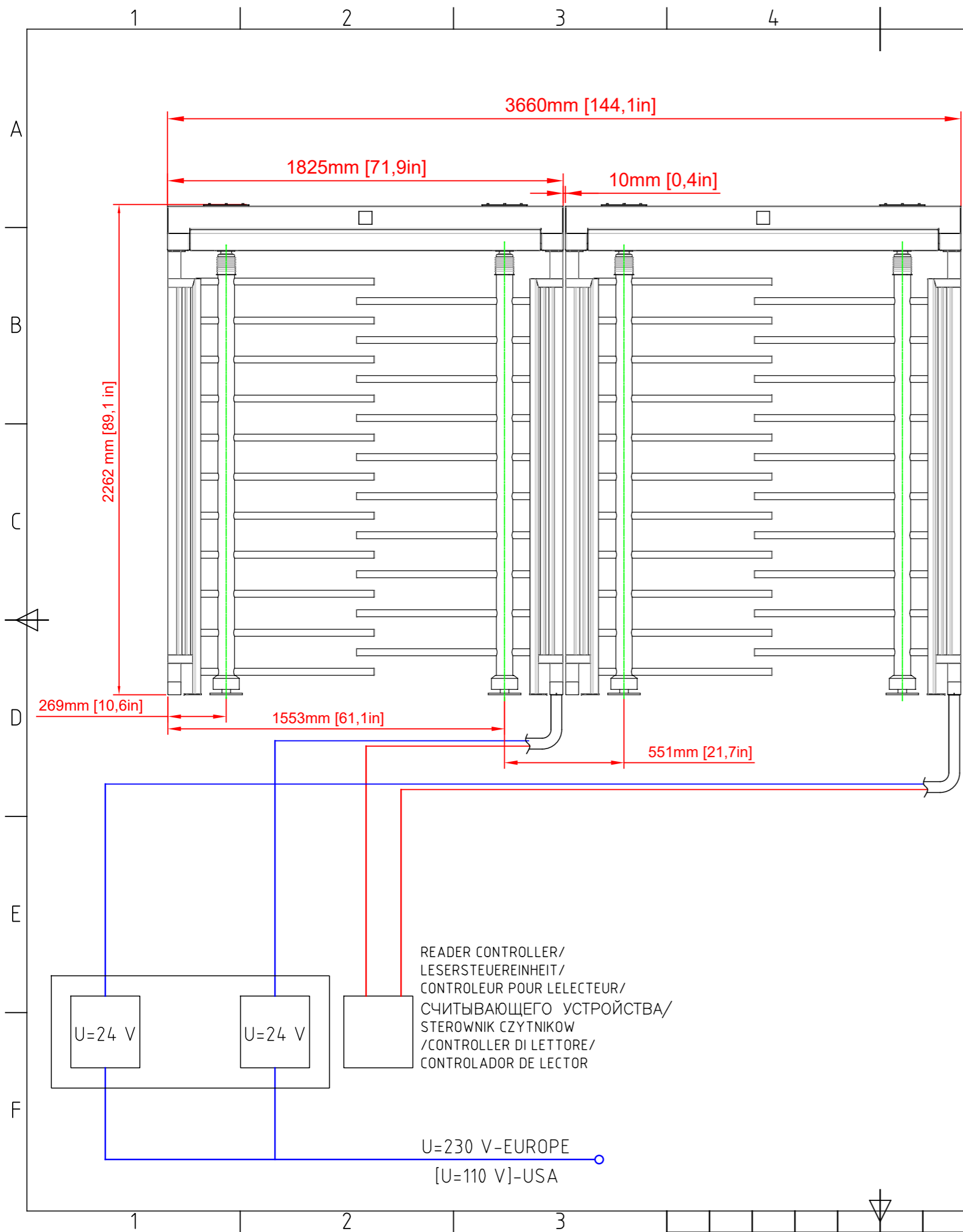

WIRING/VERDRÄHTUNG/CABLAGE/КАБЕЛЬНАЯ ПРОВОДКА/OKABLOWANIE/CABLAGGIO/CABLEADO			
TYPE/MODELL/ТИП/ TYP/TIPO/	FTP	YDYor/oder/ou/или/ lub/oppure/OMY	
QUANTITY/MENGE/ QUANTITE//СКОЛЬКО/ ILOŚĆ/NUMERO/	4	4	
SIZE/GRÖSSE / GABARIT / РАЗМЕР/ROZMIAR/ TAGLIA/TAMAÑO	8x0.5 [mm ²] 8x20 [AWG]	L < 50[m] L < 164[ft]	3x1.5 [mm ²] 3x16 [AWG]
		L > 50[m] L > 164[ft]	3x2.5 [mm ²] 3x14[AWG]

Note
1. Controllers, readers, adaptors, wires, protective pipes are not components of the device.

Bemerkung:
1. Steuereinheiten, Leser, Netzteile, Leitungen, Peschelrohre sind keine Bestandteile der Anlage.

ATTENTION!
1. LECTEURS, CONTROLEURS, PUISSANCE ELECTRIQUE, CABLES, TUYAUX FLEXIBLES, NE SONT PAS COMPOSANTS DU DISPOSITIF.

Примечание:
1.Контроллеры, считывающие устройства, питатели, провода, пешели не являются составными частями оборудования.

Uwaga:
1. Sterowniki, czytniki, zasilacze, przewody, peszle nie stanowią części składowych urządzenia.

Attenzione:
1. Controlleri, lettori, alimentatore, cavi, tubetti non fanno parte delle parti integrate del dispositivo.

Atención:
1. Drivers, lectores, alimentadores, cables, tubos no son parte de componentes del despositivo.

All Rights Reserved - GASTOP PRODUCTION LTD

GASTOP PRODUCTION LTD Krakowska 229, 32-080 Zabierzow EUROPEAN UNION, POLAND tel.: +48(12) 661 53 70 fax: +48(12) 661 53 72 e-mail: gastop@gastop.com.pl www.gastopgroup.com	NAME/NAME/APELLATION/ НАЗВАНИЕ/NAZWA/NOME/NOMBRE
	BL-2-I INSTALLATION
DATE/DATUM/DATA/ DATA/FECHA 13.03.2026	

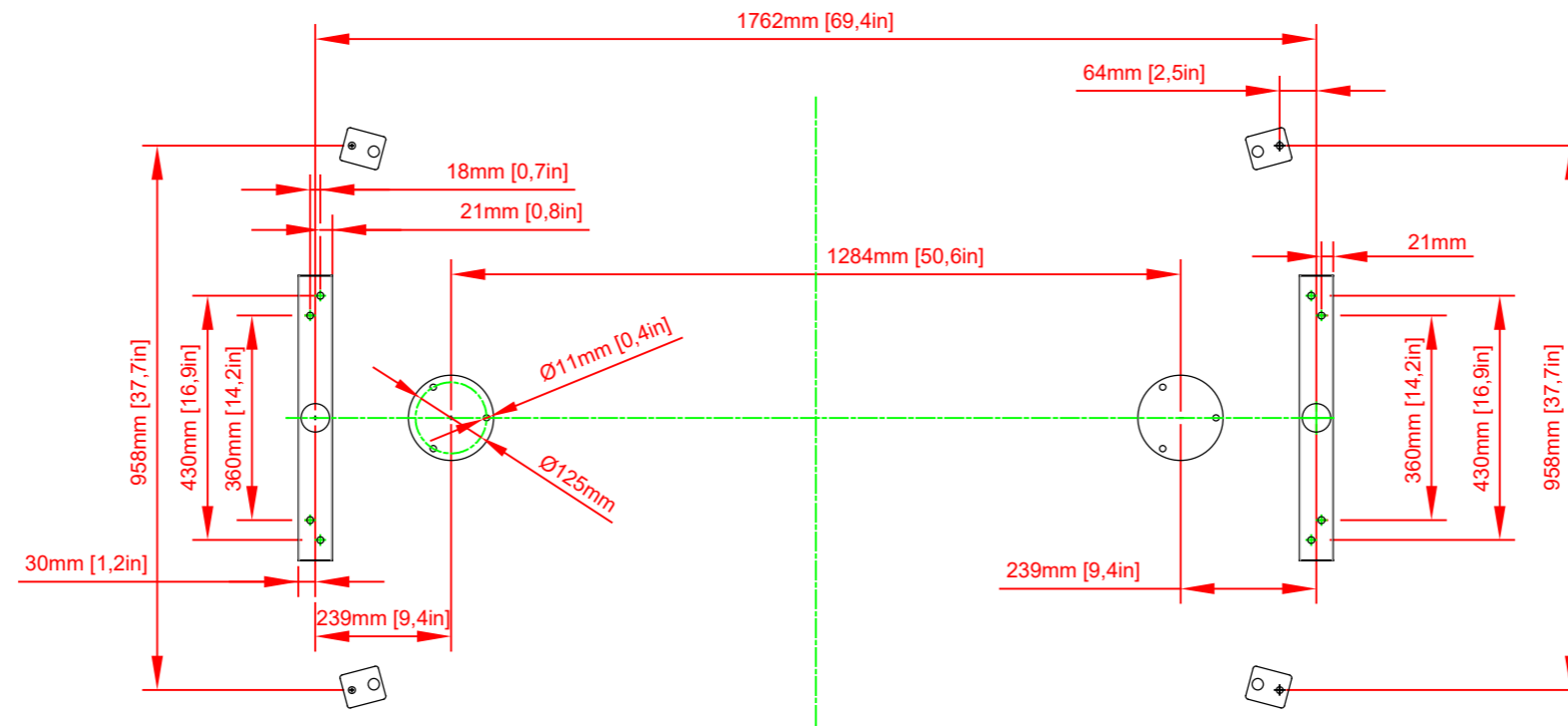

Note:

1. Drawing for initial planning where the screws holes should be. Dimensions need to be checked on a finished product.

Bemerkung:

Zeichnung zur Vorbestimmung der Anordnung von Schraubenlöchern. Die Abmessungen sind am fertigen Produkt zu prüfen.

ATTENTION:

1. Le schémat pour estimation préliminaire d'emplacement des ouvertures pour les vices.. Les dimensions doivent être vérifiées sur le produit final.

Примечание:

1.Чертеж для предварительной оценки размещения отверстий под болты. Размеры следует проверить на готовом изделии.

Uwaga:

1. Rysunek do wstępnego oszacowania rozmieszczenia otworów pod śruby. Wymiary należy sprawdzić na gotowym produkcie.

Attenzione:

1. Il disegno per la valutazione principale del collocamento dei buchi per le vite.

Le misure bisogna controllare su un prodotto pronto.

Atención:

1. El dibujo para calculación principal de distribución de aberturas por tornillos. Los tamaños hay que controlar sobre el producto acabado.

All Rights Reserved - GASTOP PRODUCTION LTD

GASTOP PRODUCTION LTD

Krakowska 229, 32-080 Zabierzow
EUROPEAN UNION, POLAND
tel.: +48(12) 661 53 70
fax: +48(12) 661 53 72
e-mail: gastop@gastop.com.pl
www.gastopgroup.com

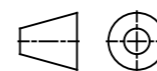

DATE/DATUM/DATA/
DATA/FECHA

13.03.2026

NAME

BL-2-I

PREPARATION FOR TRANSPORT A

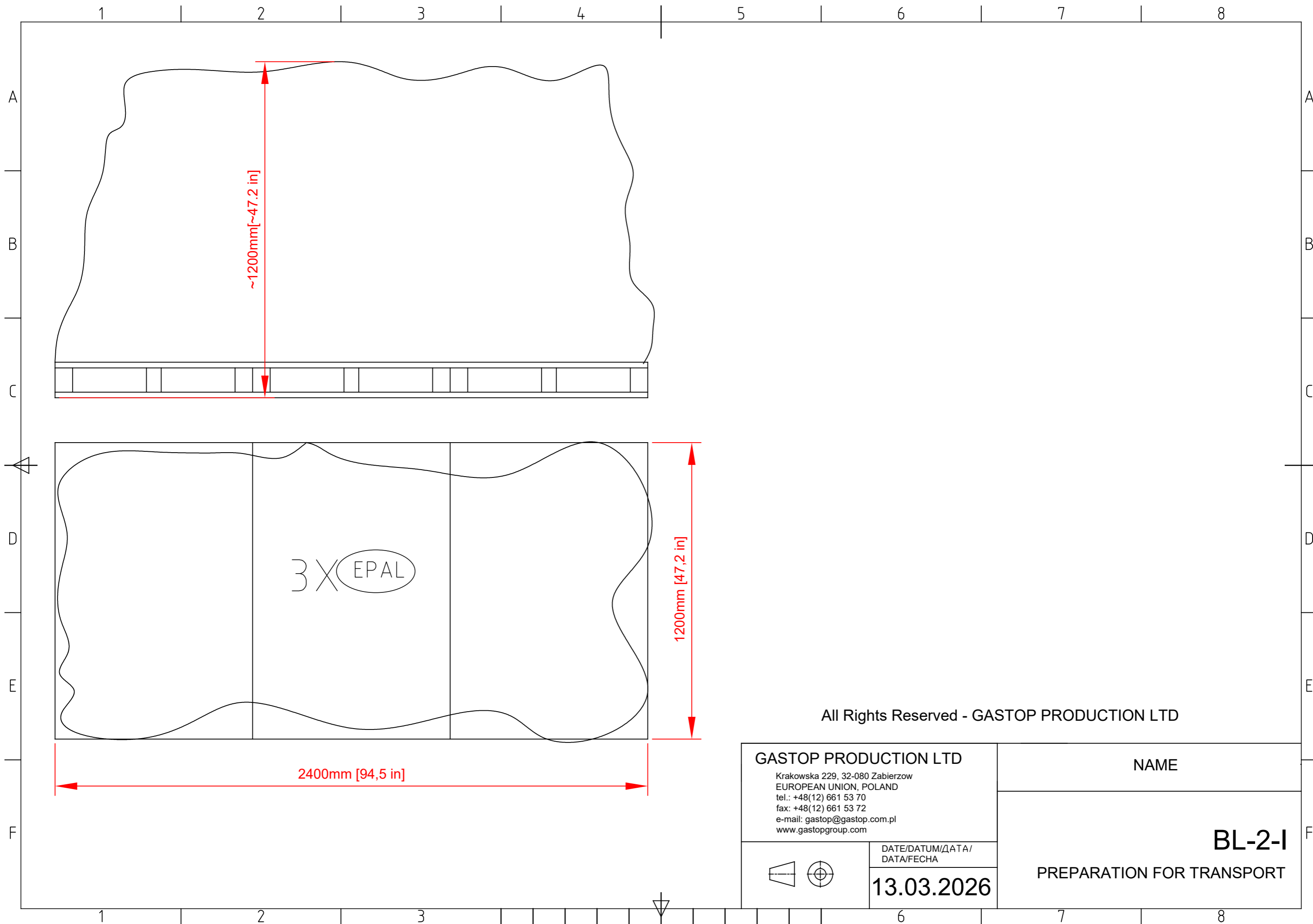

~1200mm[~47.2 in]

1200mm [47,2 in]

2400mm [94,5 in]

3 X EPAL

All Rights Reserved - GASTOP PRODUCTION LTD

GASTOP PRODUCTION LTD

Krakowska 229, 32-080 Zabierzow
 EUROPEAN UNION, POLAND
 tel.: +48(12) 661 53 70
 fax: +48(12) 661 53 72
 e-mail: gastop@gastop.com.pl
 www.gastopgroup.com

NAME

BL-2-I

PREPARATION FOR TRANSPORT

DATE/DATUM/ДАТА/
 DATA/FECHA

13.03.2026

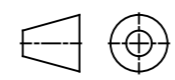

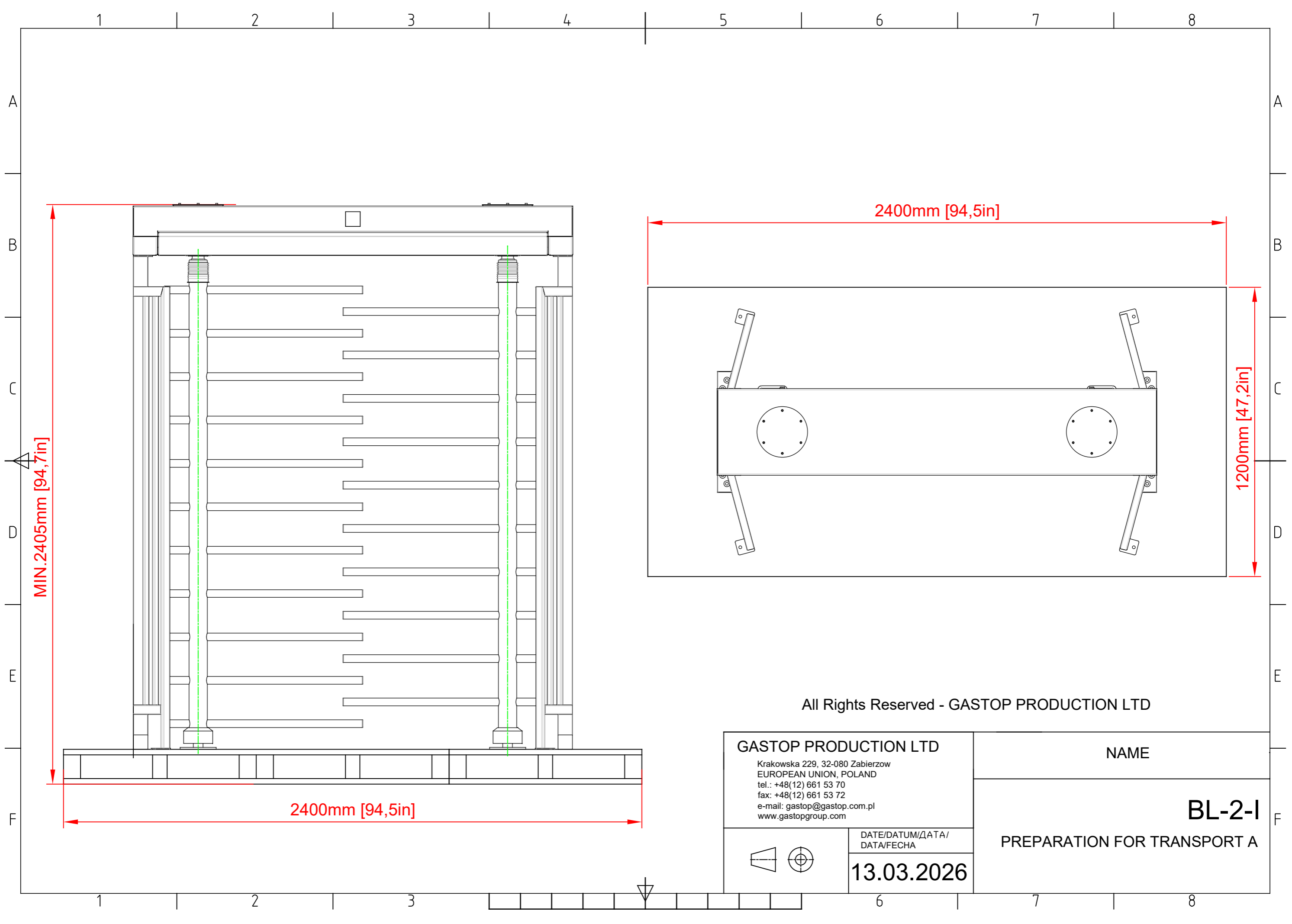

MIN.2405mm [94,7in]

2400mm [94,5in]

1200mm [47,2in]

2400mm [94,5in]

All Rights Reserved - GASTOP PRODUCTION LTD

GASTOP PRODUCTION LTD
 Krakowska 229, 32-080 Zabierzow
 EUROPEAN UNION, POLAND
 tel.: +48(12) 661 53 70
 fax: +48(12) 661 53 72
 e-mail: gastop@gastop.com.pl
 www.gastopgroup.com

DATE/DATUM/DATA/
DATA/FECHA
13.03.2026

NAME	
BL-2-I	
PREPARATION FOR TRANSPORT A	

