



# BL-2-4

TECHNICAL DRAWINGS

ALL RIGHTS RESERVED BY GASTOP PRODUCTION LTD

03.2026

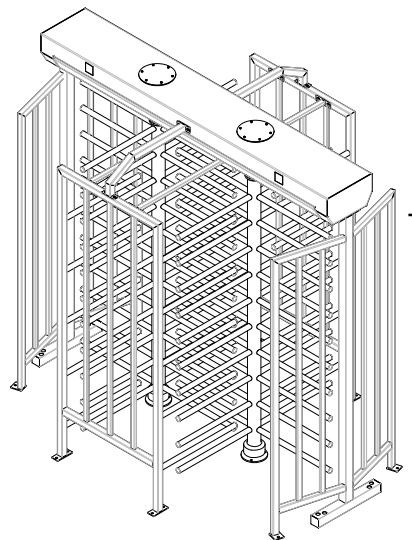
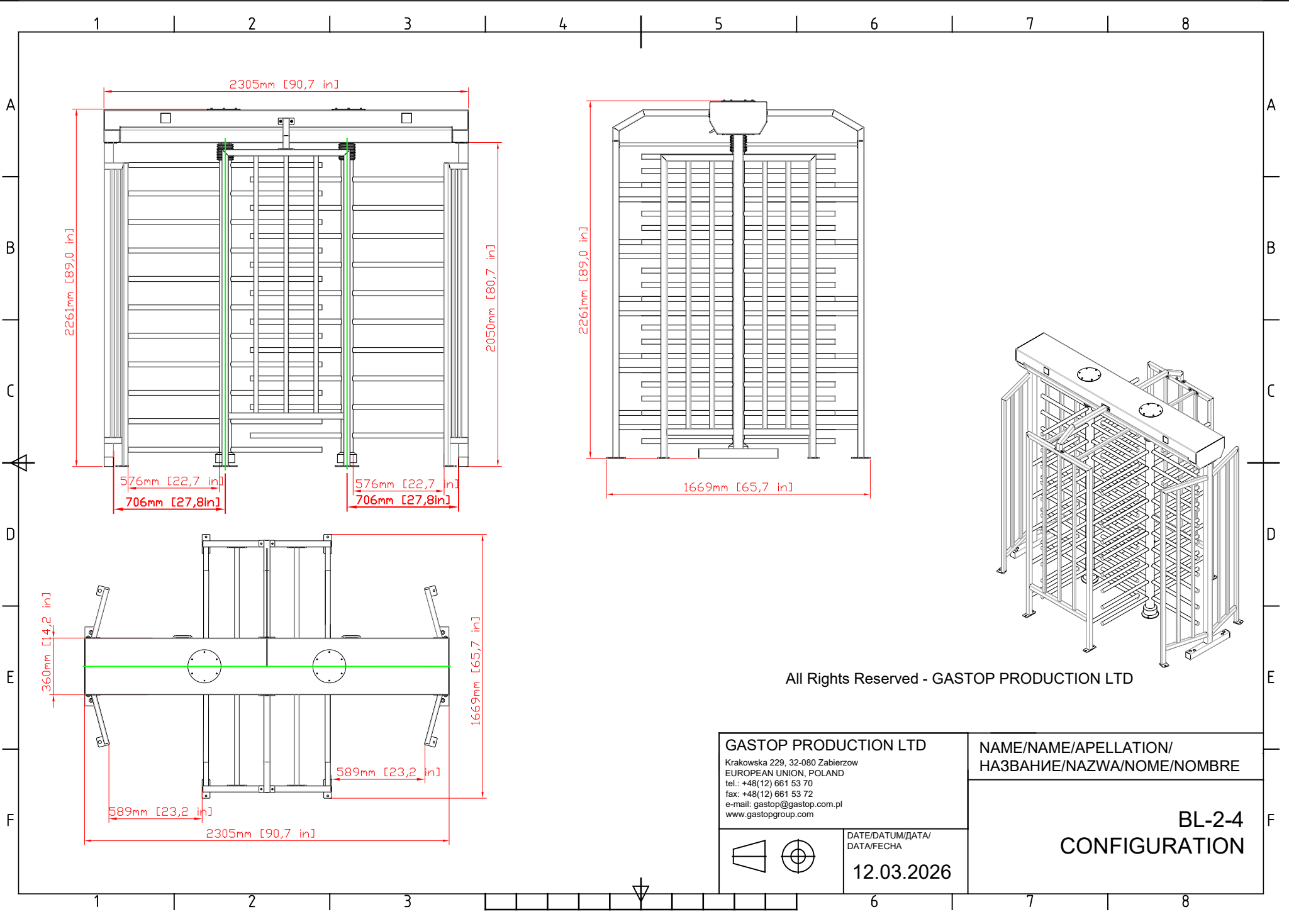

All Rights Reserved - GASTOP PRODUCTION LTD

<b>GASTOP PRODUCTION LTD</b> Krakowska 229, 32-080 Zabierzow EUROPEAN UNION, POLAND tel.: +48(12) 661 53 70 fax: +48(12) 661 53 72 e-mail: gastop@gastop.com.pl www.gastopgroup.com	NAME/NAME/APELLATION/ НАЗВАНИЕ/NAZWA/NOME/NOMBRE
	<b>BL-2-4</b> <b>CONFIGURATION</b>

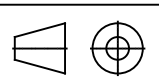

DATE/DATUM/DATA/  
 DATA/FESHA  
**12.03.2026**

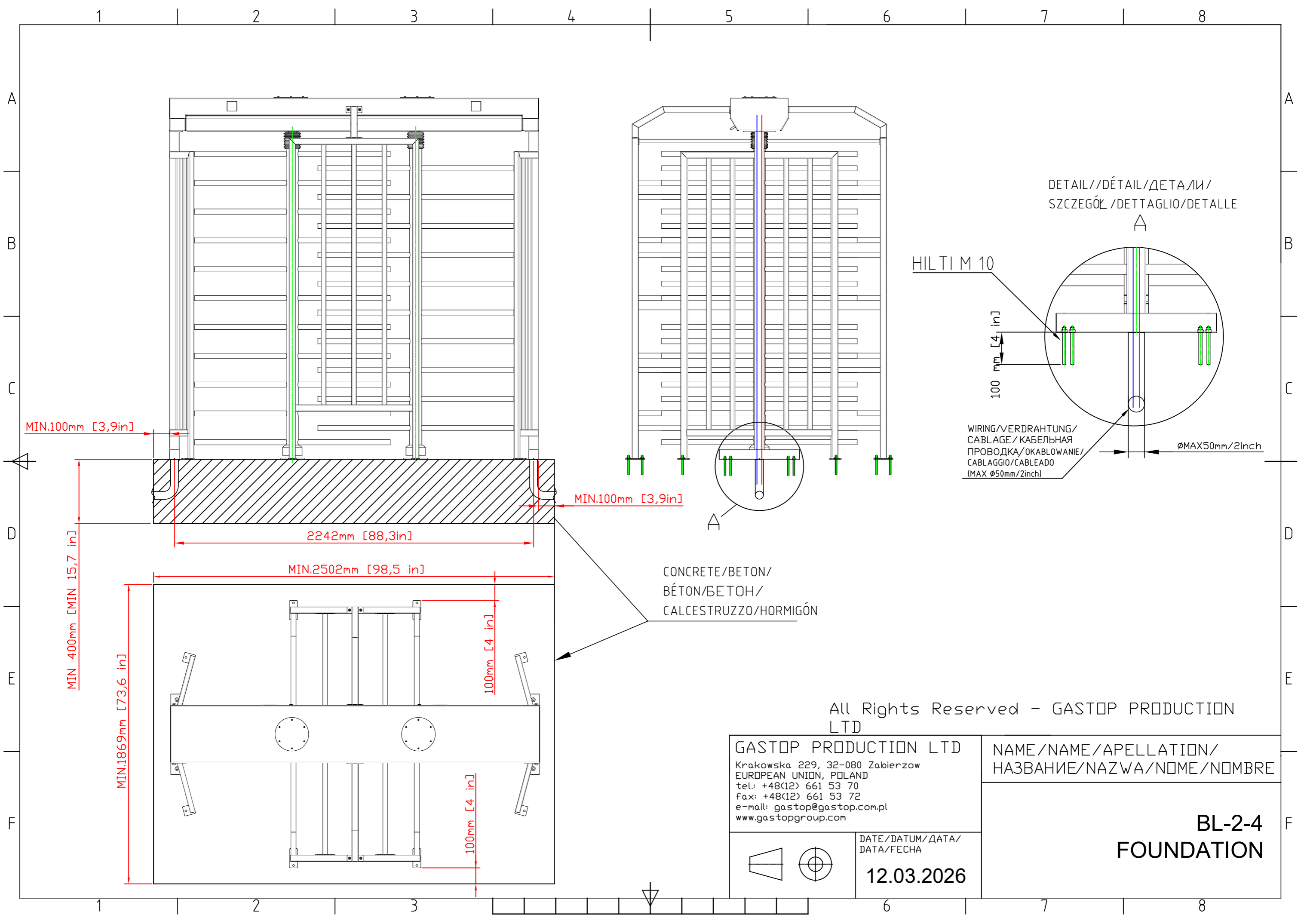

DETAIL//DÉTAIL/ДЕТАЛИ/  
SZCZEGÓŁ /DETTAGLIO/DETALLE

HILTI M 10

100 mm [4 in]

ØMAX50mm/2inch

WIRING/VERDRAHTUNG/  
CABLAGE / КАБЕЛЬНАЯ  
ПРОВОДКА/OKABLOWANIE/  
CABLAGGIO/CABLEADO  
(MAX Ø50mm/2inch)

MIN.100mm [3,9in]

2242mm [88,3in]

MIN.2502mm [98,5 in]

MIN 400mm [MIN 15,7 in]

MIN.1869mm [73,6 in]

100mm [4 in]

100mm [4 in]

CONCRETE/BETON/  
BÉTON/BETON/  
CALCESTRUZZO/HORMIGÓN

All Rights Reserved - GASTOP PRODUCTION LTD

GASTOP PRODUCTION LTD  
Krakowska 229, 32-080 Zabierzow  
EUROPEAN UNION, POLAND  
tel.: +48(12) 661 53 70  
fax: +48(12) 661 53 72  
e-mail: gastop@gastop.com.pl  
www.gastopgroup.com

NAME/NAME/APELLATION/  
НАЗВАНИЕ/NAZWA/NOME/NOMBRE

**BL-2-4  
FOUNDATION**

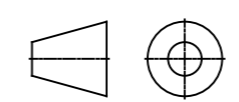

DATE/DATUM/DATA/  
DATA/FECHA  
**12.03.2026**

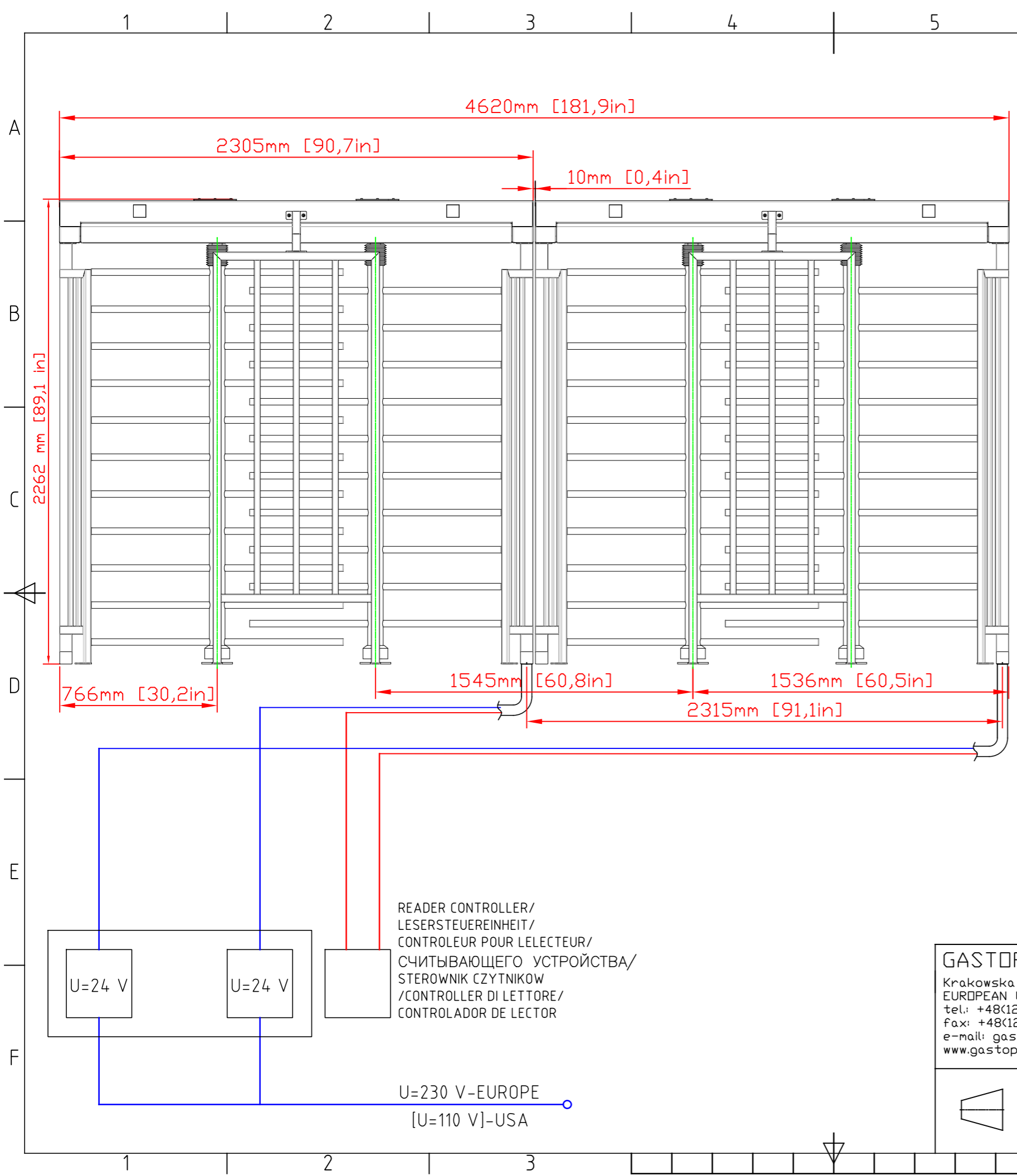

WIRING/VERDRAHTUNG/CABLAGE/КАБЕЛЬНАЯ ПРОВОДКА/OKABLOWANIE/CABLAGGIO/CABLEADO		
TYPE/MODELL/ТИП/ TYP/TIPO/	FTP	YDYor/oder/ou/или/ lub/oppure/OMY
QUANTITY/MENGE/ QUANTITE//СКОЛЬКО/ ILOŚĆ/NUMERO/	4	4
SIZE/GRÖSSE / GABARIT / PAZMEP/ROZMIAR/ TAGLIA/TAMAÑO	8x0.5 [mm <sup>2</sup> ]	L < 50[m] 3x1.5 [mm <sup>2</sup> ] L < 164[ft] 3x16 [AWG]
	8x20 [AWG]	L > 50[m] 3x2.5 [mm <sup>2</sup> ] L > 164[ft] 3x14[AWG]

Note

1. Controllers, readers, adaptors, wires, protective pipes are not components of the device.

Bemerkung:

1. Steuereinheiten, Leser, Netzteile, Leitungen, Peschelrohre sind keine Bestandteile der Anlage.

ATTENTION!

1. LECTEURS, CONTROLEURS, PUISSANCE ELECTRIQUE, CABLES, TUYAUX FLEXIBLES, NE SONT PAS COMPOSANTS DU DISPOSITIF.

Примечание:

1.Контроллеры, считывающие устройства, питатели, провода, пешели не являются составными частями оборудования.

Uwaga:

1. Sterowniki, czytniki, zasilacze, przewody, peszle nie stanowią części składowych urządzenia.

Attenzione:

1. Controlleri, lettori, alimentatore, cavi, tubetti non fanno parte delle parti integrate del dispositivo.

Atención:

1. Drivers, lectores, alimentadores, cables, tubos no son parte de componentes del dispositivo.

All Rights Reserved - GASTOP PRODUCTION LTD

GASTOP PRODUCTION LTD  
Krakowska 229, 32-080 Zabierzow  
EUROPEAN UNION, POLAND  
tel: +48(12) 661 53 70  
fax: +48(12) 661 53 72  
e-mail: gastop@gastop.com.pl  
www.gastopgroup.com

DATE/DATUM/DATA/  
DATA/FECHA  
**12.03.2026**

NAME/NAME/APELLATION/  
HAZWANIE/NAZWA/NOME/NOMBRE

**BL-2-4  
INSTALLATION**

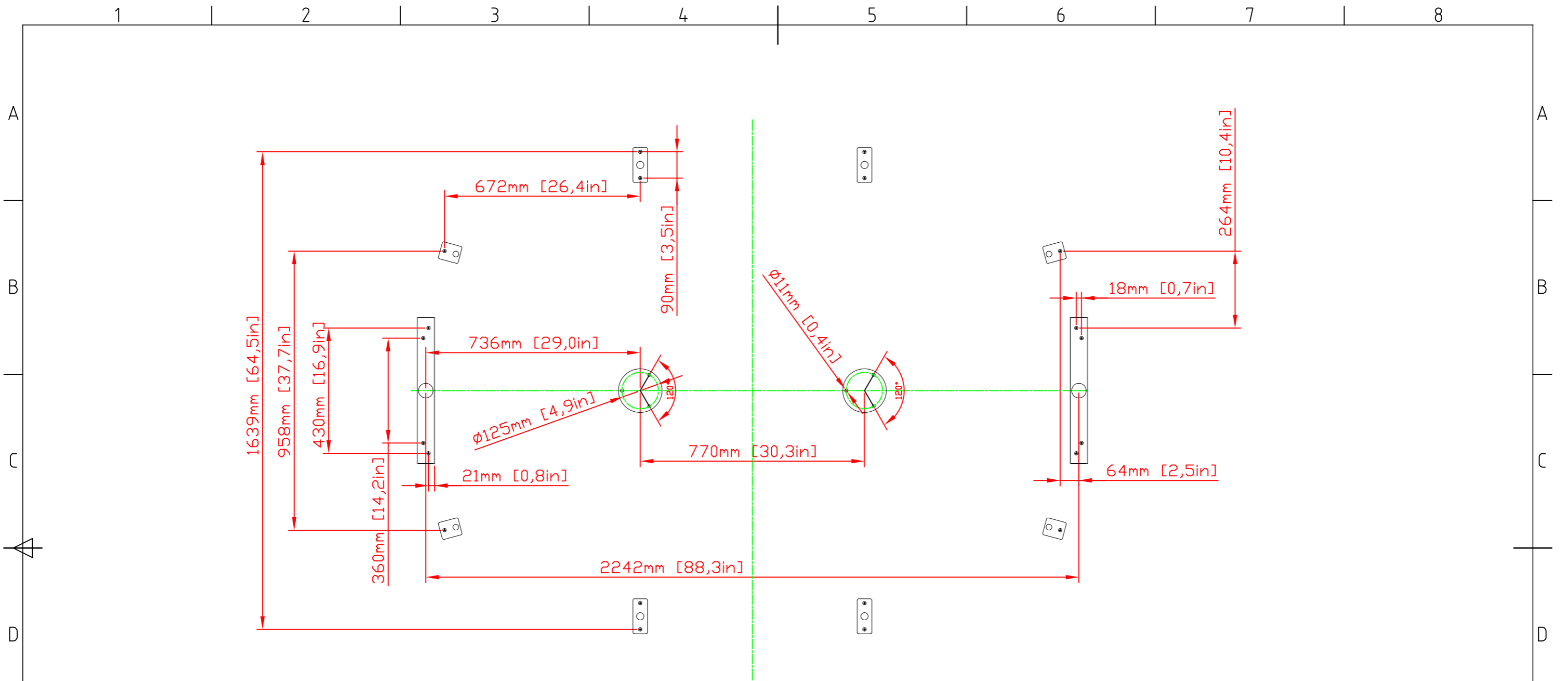

Note:  
 1. Drawing for initial planning where the screws holes should be. Dimensions need to be checked on a finished product.

Bemerkung:  
 Zeichnung zur Vorbestimmung der Anordnung von Schraubenlöchern. Die Abmessungen sind am fertigen Produkt zu prüfen.

ATTENTION:  
 1. Le schémat pour estimation préliminaire d'emplacement des ouvertures pour les vices. Les dimensions doivent être vérifiées sur le produit final.

Примечание:  
 1.Чертеж для предварительной оценки размещения отверстий под болты. Размеры следует проверить на готовом изделии.

Uwaga:  
 1. Rysunek do wstępnego oszacowania rozmieszczenia otworów pod śruby. Wymiary należy sprawdzić na gotowym produkcie.

Attenzione:  
 1. Il disegno per la valutazione principale del collocamento dei buchi per le vite.

Le misure bisogna controllare su un prodotto pronto.

Atención:  
 1. El dibujo para calculación principal de distribución de aberturas por tornillos. Los tamaños hay que controlar sobre el producto acabado.

All Rights Reserved - GASTOP PRODUCTION LTD

GASTOP PRODUCTION LTD Krakowska 229, 32-080 Zabierzow EUROPEAN UNION, POLAND tel.: +48(12) 661 53 70 fax: +48(12) 661 53 72 e-mail: gastop@gastop.com.pl www.gastopgroup.com	NAME
	<b>BL-2-4</b> PREPARATION FOR TRANSPORT A
	DATE/DATUM/DATA/ DATA/FECHA <b>12.03.2026</b>

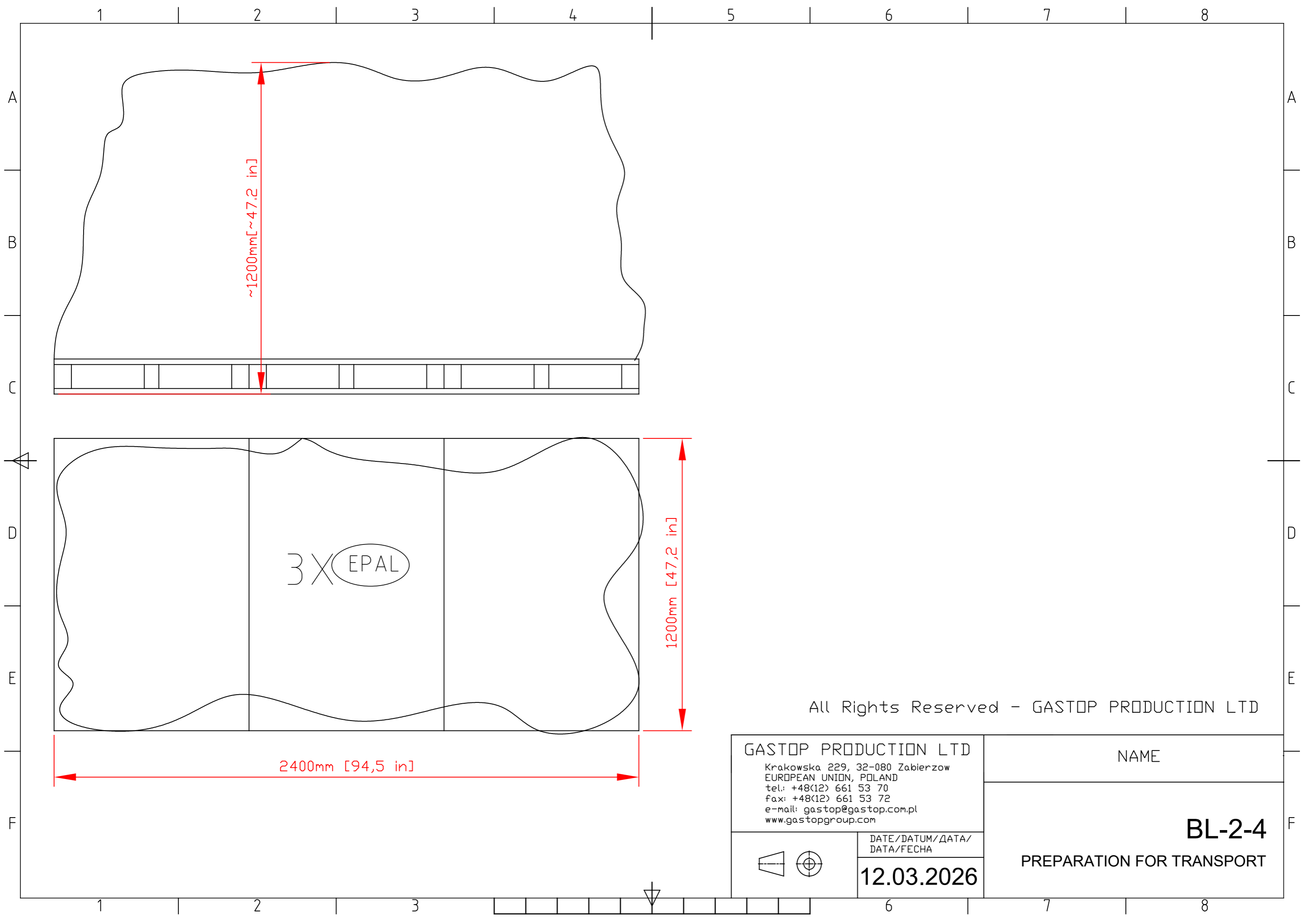

~1200mm [~47.2 in]

1200mm [47,2 in]

2400mm [94,5 in]

3 X EPAL

All Rights Reserved - GASTOP PRODUCTION LTD

GASTOP PRODUCTION LTD Krakowska 229, 32-080 Zabierzow EUROPEAN UNION, POLAND tel.: +48(12) 661 53 70 fax: +48(12) 661 53 72 e-mail: gastop@gastop.com.pl www.gastopgroup.com	NAME
	<b>BL-2-4</b>
DATE/DATUM/DATA/ DATA/FECHA <b>12.03.2026</b>	PREPARATION FOR TRANSPORT

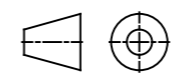

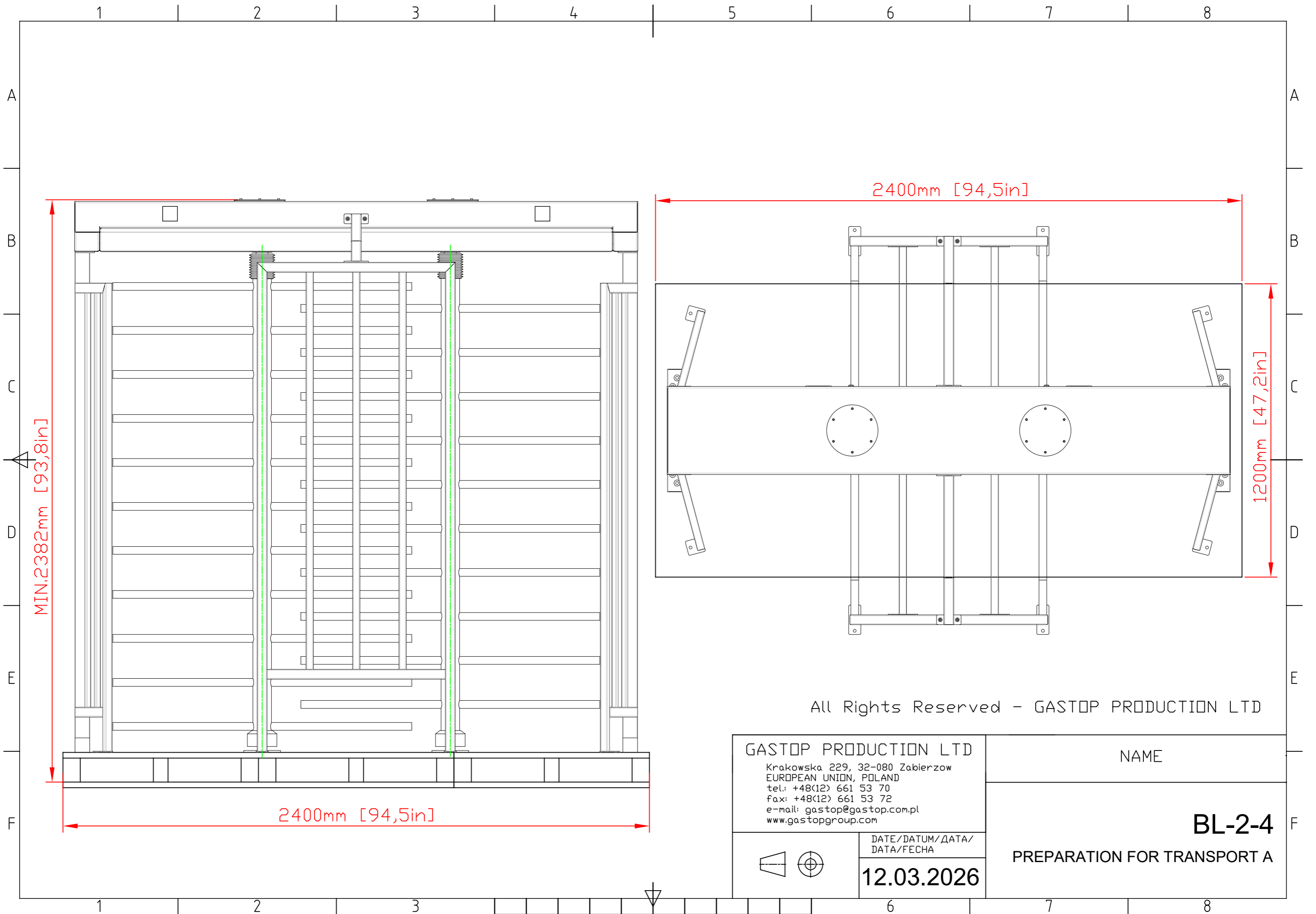

All Rights Reserved - GASTOP PRODUCTION LTD

GASTOP PRODUCTION LTD

Krakowska 229, 32-080 Zabierzow  
 EUROPEAN UNION, POLAND  
 tel.: +48(12) 661 53 70  
 fax: +48(12) 661 53 72  
 e-mail: gastop@gastop.com.pl  
 www.gastopgroup.com

NAME

**BL-2-4**

PREPARATION FOR TRANSPORT A

DATE/DATUM/DATA/  
 DATA/FECHA

**12.03.2026**

