



# BL-1-I

TECHNICAL DRAWINGS

ALL RIGHTS RESERVED BY GASTOP PRODUCTION LTD

03.2026

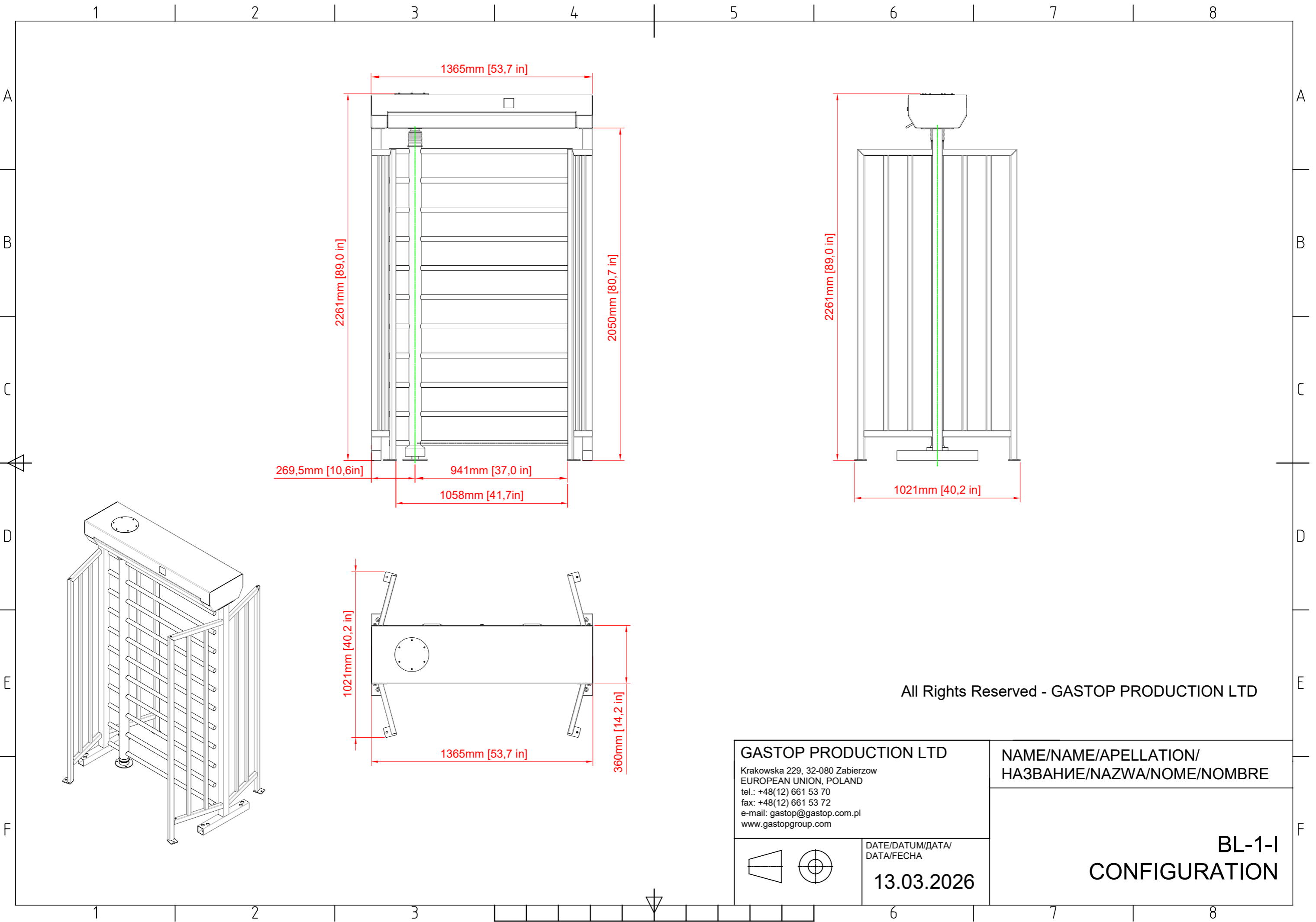

All Rights Reserved - GASTOP PRODUCTION LTD

**GASTOP PRODUCTION LTD**

Krakowska 229, 32-080 Zabierzow  
 EUROPEAN UNION, POLAND  
 tel.: +48(12) 661 53 70  
 fax: +48(12) 661 53 72  
 e-mail: gastop@gastop.com.pl  
 www.gastopgroup.com

NAME/NAME/APELLATION/  
 НАЗВАНИЕ/NAZWA/NOME/NOMBRE

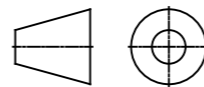

DATE/DATUM/DATA/  
 DATA/FECHA

13.03.2026

**BL-1-I  
 CONFIGURATION**

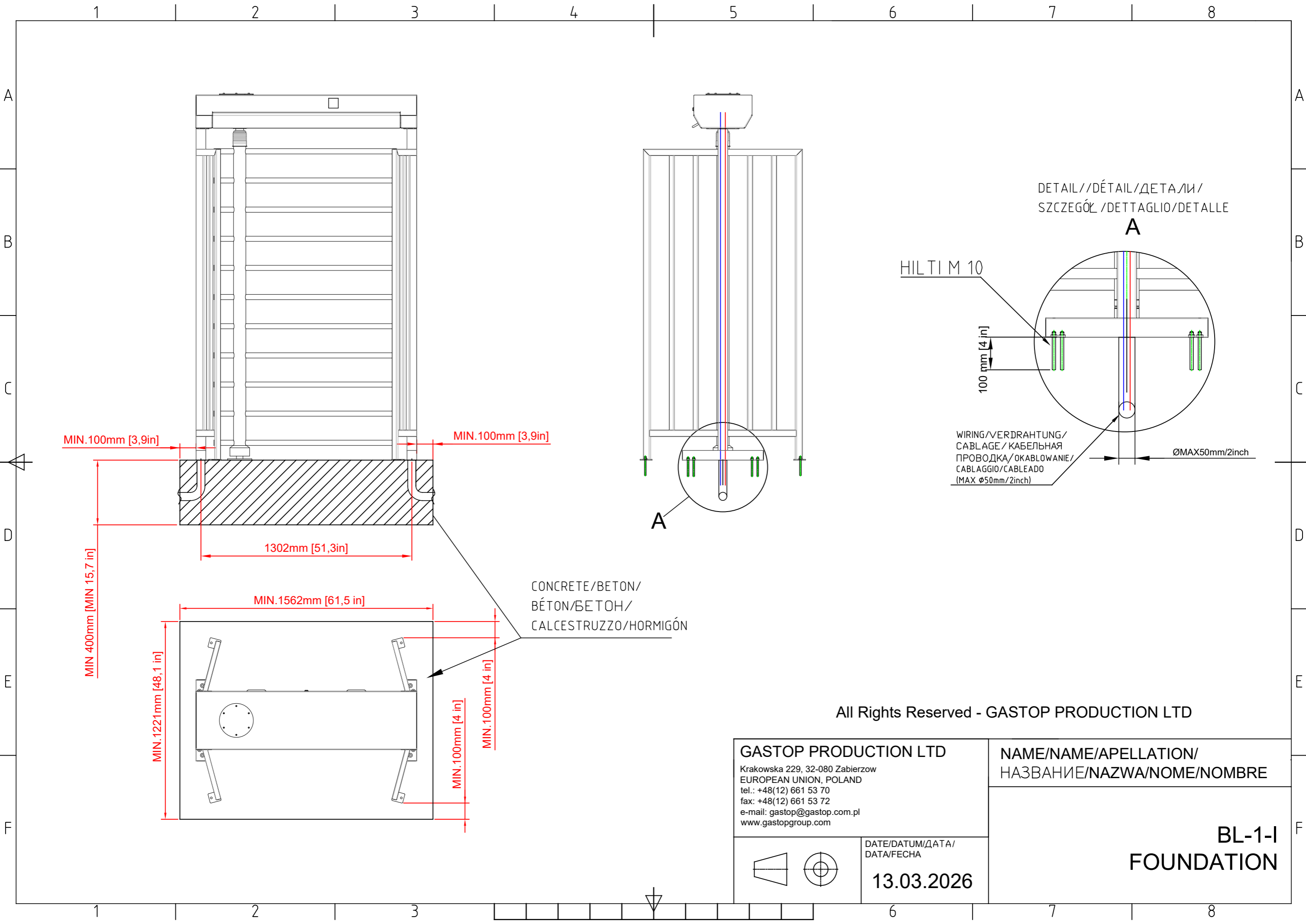

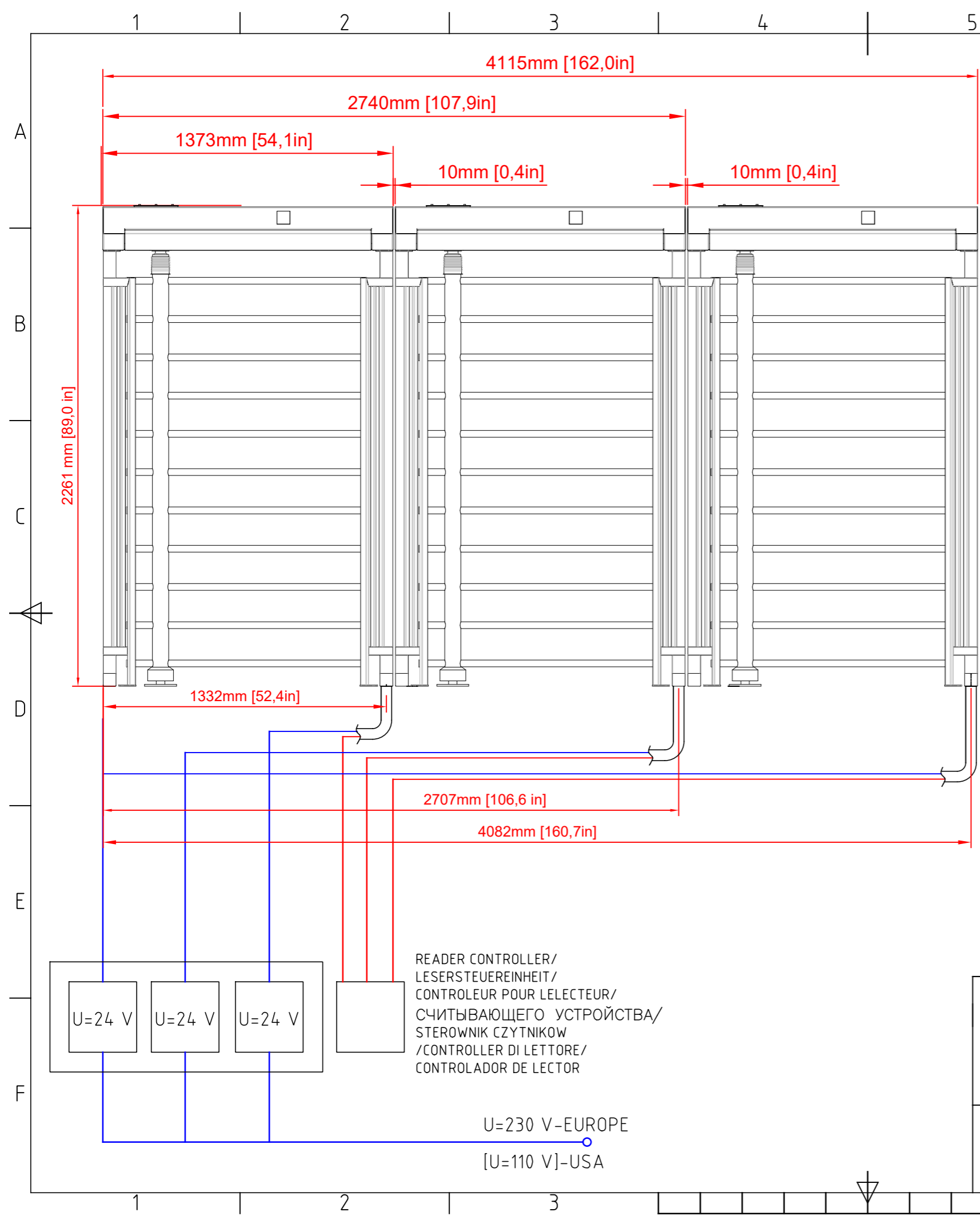

WIRING/VERDRAHTUNG/CABLAGE/КАБЕЛЬНАЯ ПРОВОДКА/OKABLOWANIE/CABLAGGIO/CABLEADO			
TYPE/MODELL/ТИП/ TYP/TIPO/	FTP	YDYor/oder/ou/или/ lub/oppure/OMY	
QUANTITY/MENGE/ QUANTITE//СКОЛЬКО/ ILOŚĆ/NUMERO/	3	3	
SIZE/GRÖSSE / GABARIT / PAZMER/ROZMIAR/ TAGLIA/TAMAÑO	8x0.5 [mm^2] 8x20 [AWG]	L < 50[m] L < 164[ft]	3x1.5 [mm^2] 3x16 [AWG]
		L > 50[m] L > 164[ft]	3x2.5 [mm^2] 3x14[AWG]

Note

1. Controllers, readers, adaptors, wires, protective pipes are not components of the device.

Bemerkung:

1. Steuereinheiten, Leser, Netzteile, Leitungen, Peschelrohre sind keine Bestandteile der Anlage.

ATTENTION!

1. LECTEURS, CONTROLEURS, PUISSANCE ELECTRIQUE, CABLES, TUYAUX FLEXIBLES, NE SONT PAS COMPOSANTS DU DISPOSITIF.

Примечание:

1. Контроллеры, считывающие устройства, питатели, провода, пешели не являются составными частями оборудования.

Uwaga:

1. Sterowniki, czytniki, zasilacze, przewody, peszle nie stanowią części składowych urządzenia.

Attenzione:

1. Controlleri, lettori, alimentatore, cavi, tubetti non fanno parte delle parti integrate del dispositivo.

Atención:

1. Drivers, lectores, alimentadores, cables, tubos no son parte de componentes del dispositivo.

All Rights Reserved - GASTOP PRODUCTION LTD

**GASTOP PRODUCTION LTD**  
 Krakowska 229, 32-080 Zabierzow  
 EUROPEAN UNION, POLAND  
 tel.: +48(12) 661 53 70  
 fax: +48(12) 661 53 72  
 e-mail: gastop@gastop.com.pl  
 www.gastopgroup.com

DATE/DATUM/DATA/  
DATA/FECHA  
**13.03.2026**

NAME/NAME/APELLATION/  
НАЗВАНИЕ/NAZWA/NOME/NOMBRE

**BL-1-I  
INSTALLATION**

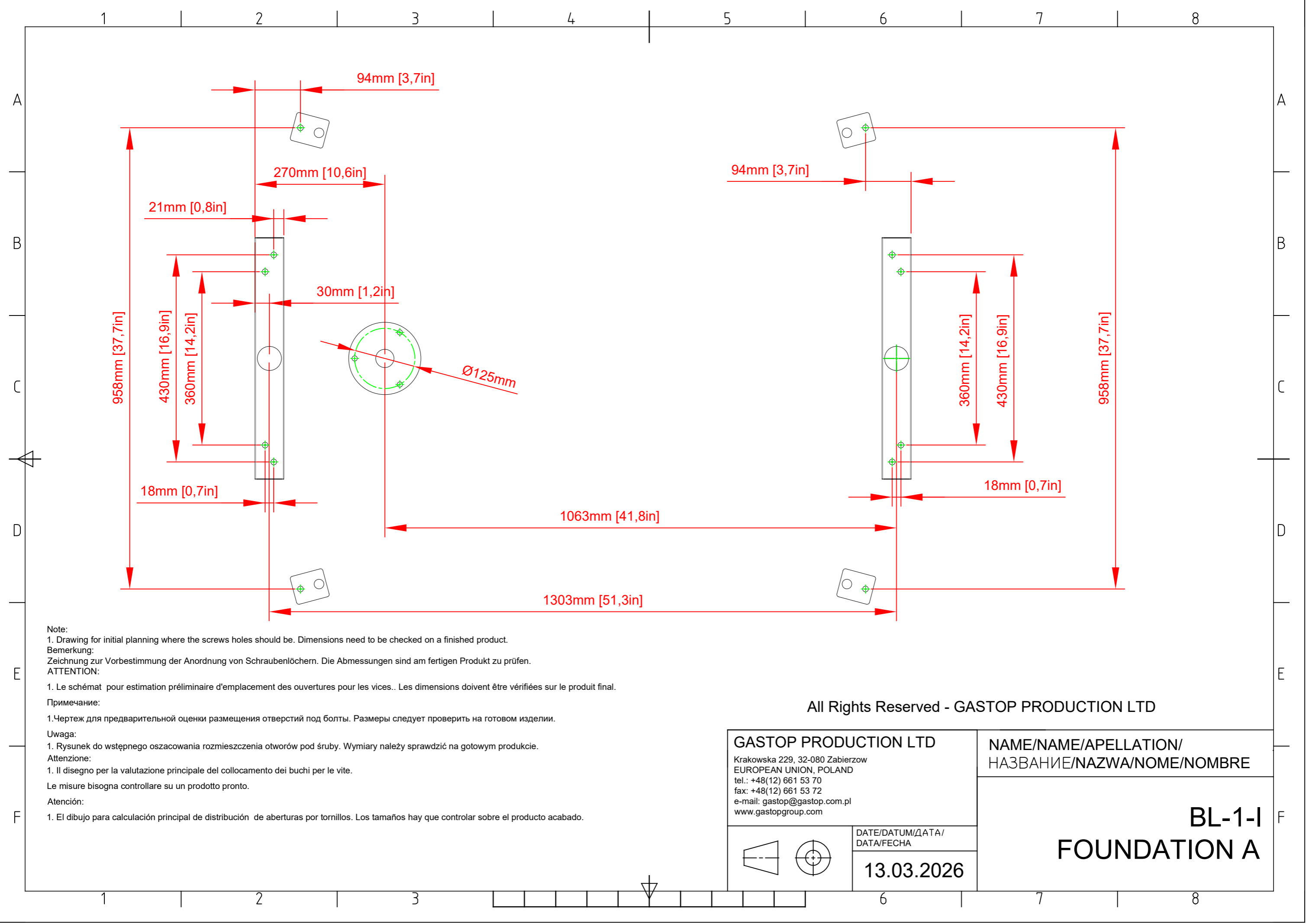

Note:  
 1. Drawing for initial planning where the screws holes should be. Dimensions need to be checked on a finished product.  
 Bemerkung:  
 Zeichnung zur Vorbestimmung der Anordnung von Schraubenlöchern. Die Abmessungen sind am fertigen Produkt zu prüfen.  
 ATTENTION:  
 1. Le schémat pour estimation préliminaire d'emplacement des ouvertures pour les vices.. Les dimensions doivent être vérifiées sur le produit final.  
 Примечание:  
 1. Чертеж для предварительной оценки размещения отверстий под болты. Размеры следует проверить на готовом изделии.  
 Uwaga:  
 1. Rysunek do wstępnego oszacowania rozmieszczenia otworów pod śruby. Wymiary należy sprawdzić na gotowym produkcie.  
 Attenzione:  
 1. Il disegno per la valutazione principale del collocamento dei buchi per le vite.  
 Le misure bisogna controllare su un prodotto pronto.  
 Atención:  
 1. El dibujo para calculación principal de distribución de aberturas por tornillos. Los tamaños hay que controlar sobre el producto acabado.

All Rights Reserved - GASTOP PRODUCTION LTD

<b>GASTOP PRODUCTION LTD</b> Krakowska 229, 32-080 Zabierzow EUROPEAN UNION, POLAND tel.: +48(12) 661 53 70 fax: +48(12) 661 53 72 e-mail: gastop@gastop.com.pl www.gastopgroup.com	NAME/NAME/APELLATION/ НАЗВАНИЕ/NAZWA/NOME/NOMBRE
	<b>BL-1-I</b> <b>FOUNDATION A</b>
DATE/DATUM/DATA/ DATA/FECHA <b>13.03.2026</b>	

1 2 3 4 5 6 7 8

A

B

C

D

E

F

A

B

C

D

E

F

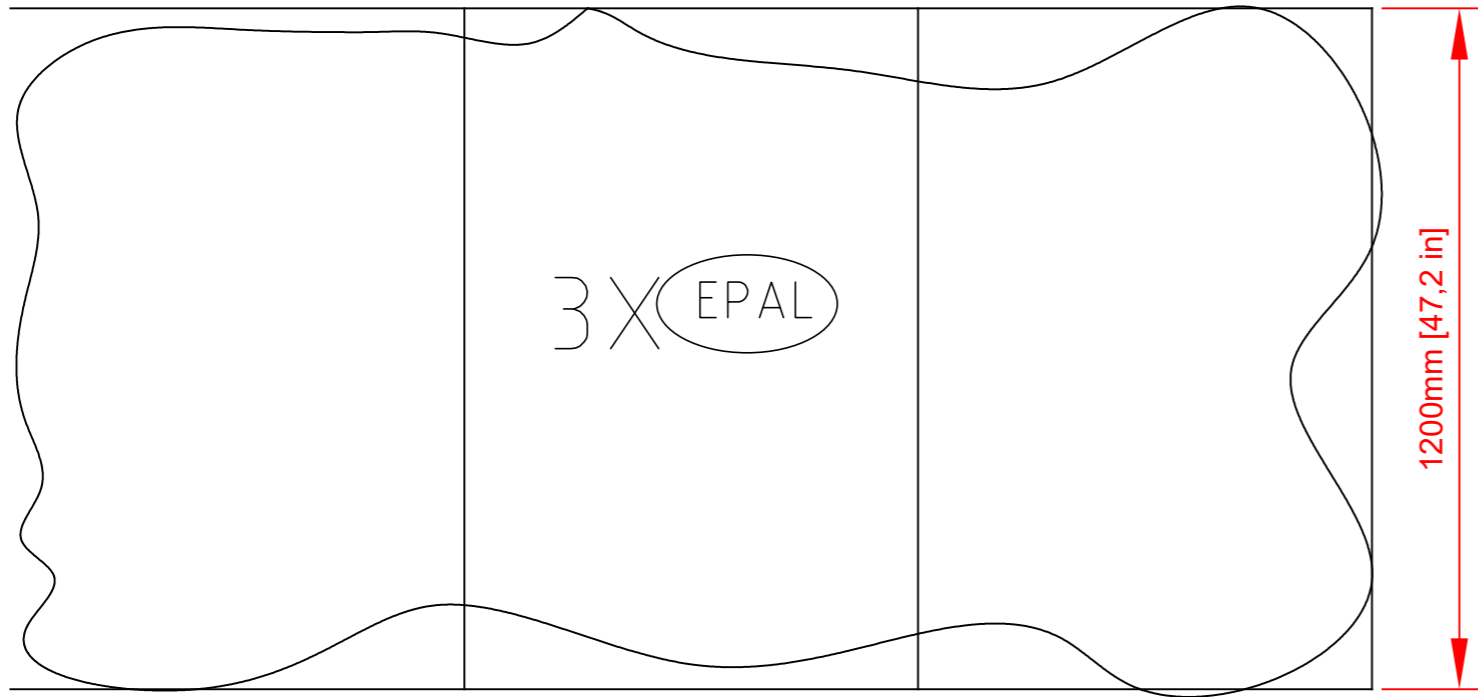
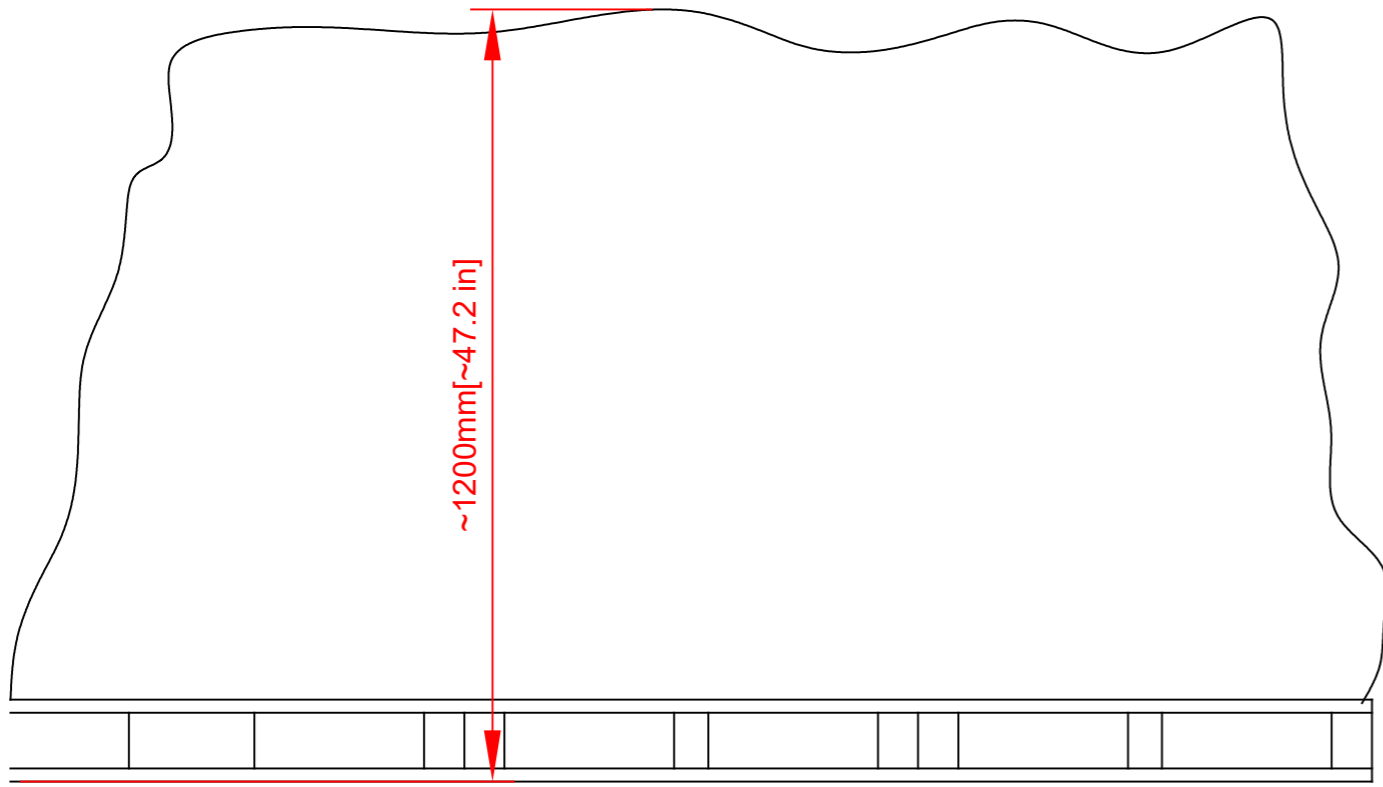

All Rights Reserved - GASTOP PRODUCTION LTD

<b>GASTOP PRODUCTION LTD</b> Krakowska 229, 32-080 Zabierzow EUROPEAN UNION, POLAND tel.: +48(12) 661 53 70 fax: +48(12) 661 53 72 e-mail: gastop@gastop.com.pl www.gastopgroup.com	
	DATE/DATUM/DATA/ DATA/FECHA
	<b>13.03.2026</b>

NAME
<b>BL-1-I</b>
PREPARATION FOR TRANSPORT

1 2 3 4 5 6 7 8

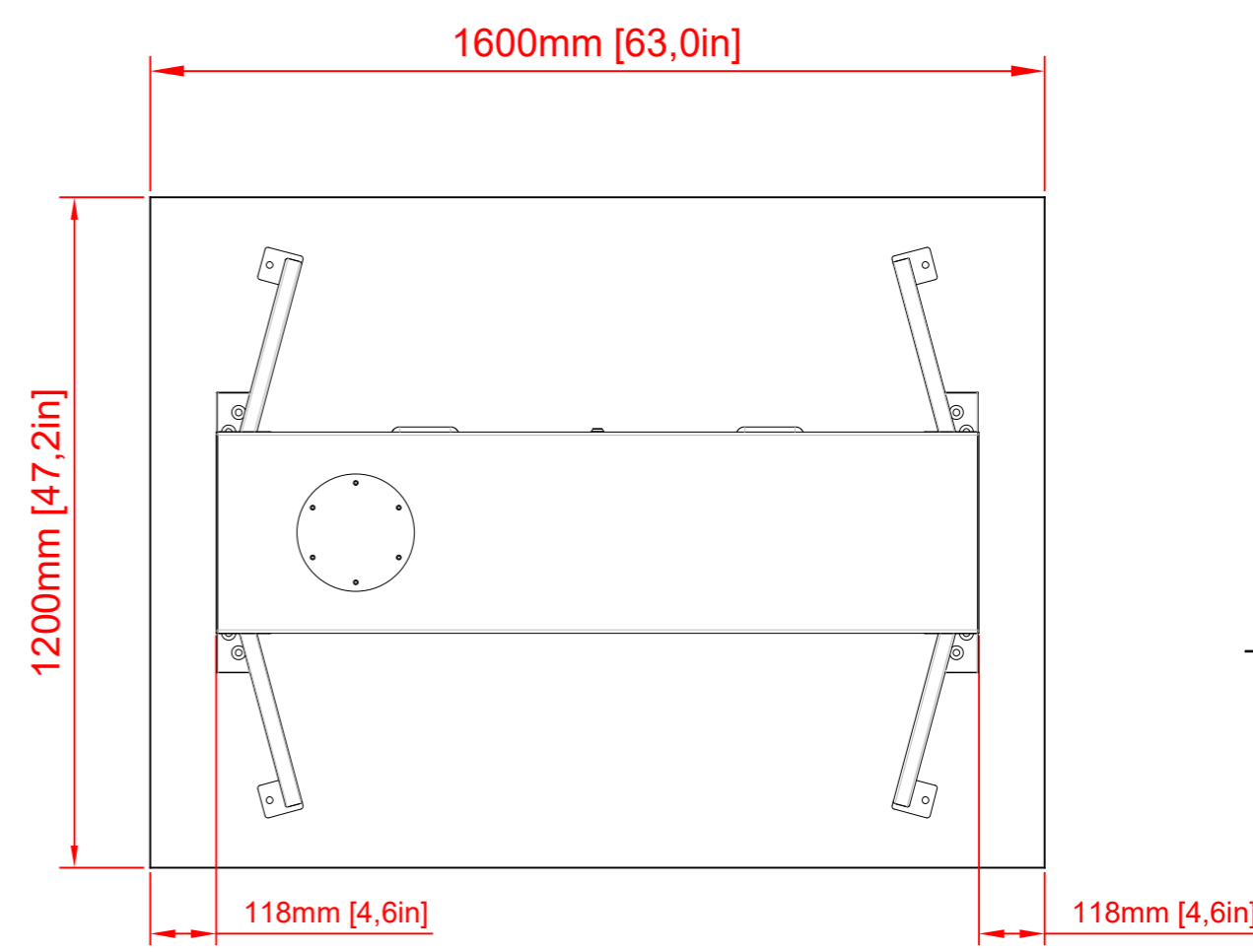
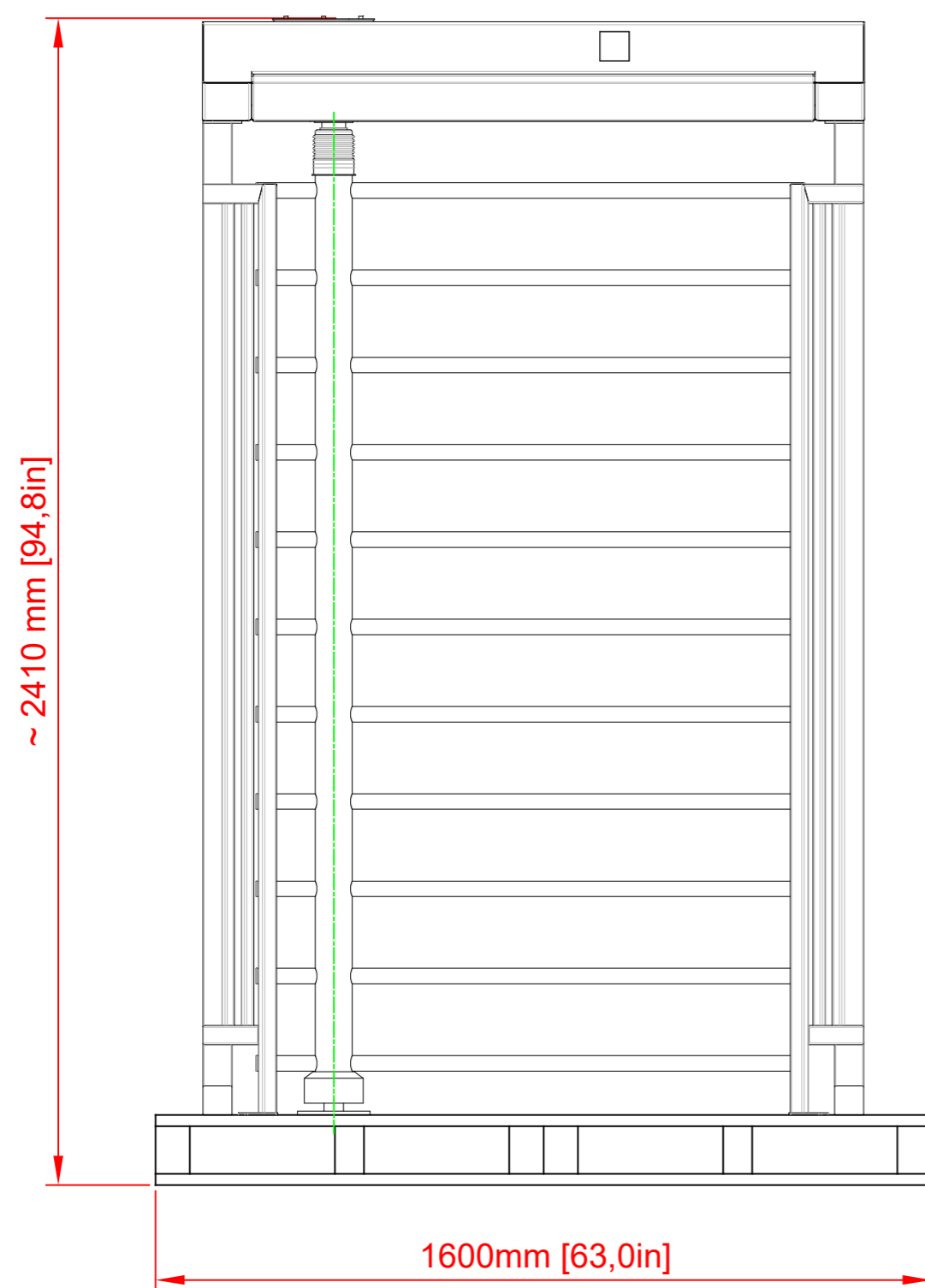

All Rights Reserved - GASTOP PRODUCTION LTD

<b>GASTOP PRODUCTION LTD</b> Krakowska 229, 32-080 Zabierzow EUROPEAN UNION, POLAND tel.: +48(12) 661 53 70 fax: +48(12) 661 53 72 e-mail: gastop@gastop.com.pl www.gastopgroup.com	NAME
	<b>BL-1-I</b> PREPARATION FOR TRANSPORT A
	DATE/DATUM/DATA/ DATA/FECHA <b>13.03.2026</b>